

Servomotors

Order Catalogue

Series:

- LSH servomotors,
nominal torque: 0.2 to 21 Nm
- LST servomotors,
nominal torque: 0.1 to 60 Nm
- LSx servomotors
with 24 V and 48 V windings,
nominal torque: 0.1 to 0.8 Nm



Servomotors order catalogue

ID no.: 0814.25B.3-00

Date: 12/2007

We reserve the right to make technical changes.

Servomotors

The following double page spread shows you an overview of the contents of the order catalogue.

Please also take some time to read the first chapter “Servomotors overview”. This gives you concise information on the performance capabilities of LSH and LST servomotors.

1

2



3



4



5

6



7

Choosing the right motor, LSH or LST	1-1
Order code / Basic configuration	1-3
Typical M-n characteristics	1-6
Permissible axial and lateral forces	1-7
Connections	1-8

Servomotors overview

1

Motor type LSH-050	2-2
Motor type LSH-074	2-6
Motor type LSH-097	2-14
Motor type LSH-127	2-22

LSH servomotors

2

Motor type LST-037	3-4
Motor type LST-050	3-8
Motor type LST-074	3-12
Motor type LST-097	3-20
Motor type LST-127	3-28
Motor type LST-158	3-32
Motor type LST-190	3-36
Motor type LST-220	3-40

LST servomotors

3

Motor type LST-037-x-xx-24	4-2
Motor type LSH-050-x-30-48	4-6

LSx servomotors with 24 V and 48 V windings

4

Encoders list	5-1
---------------------	-----

Encoders

5

Ready made-up encoder cables	6-2
Ready made-up motor cables	6-3

Accessories

6

Holding brake	7-1
Technical data	7-2

Appendix

7

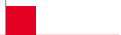

Procedure for selecting a motor

Basic considerations		In order to select the correct drive and motor, the specific speed and the load cycle for the drive task must be known.
1.		Determine the Index of Protection: IP64, IP65
2.		Determine the supply voltage: 230 V to 400 V
3.		Determine the space available
4.		Determine the maximum torque from the load cycle profile; see the c-line drives project planning manual, in the appendix page 18 on our product CD.
5.		Determine the average (effective) torque; see the c-line drives project planning manual, in the appendix page 18 on our product CD.
6.		Determine the type of motor required: LSH/LST, see page 1-2
7.		On the respective data page, select the motor which satisfies the following criteria: Synchronous servomotor: $n_{max} \leq 1.1 \cdot n_{nenn}$ $M_{eff} \leq M_{nenn}$
8.		Determine the necessary encoder system: Resolver, incremental encoder sin/cos 1 V _{pp} , absolute value encoder; see chapter 6, Encoders
9.		Complete motor designation with all necessary options (type code); see page 1-4
10.		Determine the length and cross-section of the ready made-up power cable required, or determine the plug size for customer installation; see the c-line drives project planning manual, in the appendix page 18 on our product CD.
11.		Determine the ready made-up encoder cable required, or determine the plug size for customer installation, HTL incremental encoder, resolver, sin/cos 1 V _{pp} incremental encoder, absolute value encoder; see chapter 6
12.		Refer to the selection and ordering data to select the inverter / servocontroller for the selected motor, based on the standard overload conditions. The inverter / servocontroller should be selected for the respective motor standstill current and motor rated current.

The correct choice of motor: LSH or LST?

Irrespective of which variant you select: in either case you have chosen a high quality synchronous servomotor.

This is because the LSH, like the LST motor also, is fitted exclusively with high-quality bearings, an identical flange, the same insulation system and the same encoder system. In short: the mechanical aspects are absolutely identical and offer exactly the same very high quality level!

The LST motor differs from the LSH motor in the arrangement of the stator laminations packet and the number of pole pairs on the rotor. Whilst the LSH motor incorporates the new concentrated winding, the LST motor relies on the conventional 6-pole stator winding with the well-known characteristics of a dynamic synchronous servomotor, using neodymium-iron-boron magnets.

Whilst the LST motor with its conventional "split winding" has a relatively large winding end overhang, this is eliminated on the LSH motor with its "compressed winding" technique.

Especially for motors with short lamination packets, the conventional winding end overhang on the LST can occupy half the length of the stator. This length contributes nothing to the development of torque and is eliminated on the LSH motor.

This results in a shorter motor with a higher torque and up to 100 % better dynamic response. In addition, the savings in materials and manufacturing hours enable us to offer LSH motors at prices up to 20 % lower. To summarise the different characteristics:

	LSH motor type	LST motor type
Winding technique	Compressed winding technique	Conventional "split" winding
Design	10-pole rotor (exception: LSH-050 = 6-pole)	6-pole design
Nominal frequency	up to 250 Hz at 3000 rpm (exception: LSH-050 up to 225 Hz at 4500 rpm)	up to 150 Hz at 3000 rpm
Smooth running	very good	very good
Sizes	LSH-050 up to LSH-127	LST-037 up to LST-220
Moment of inertia	approx. 60 % of the LST motor	100 %
Price / performance	very good	good

Comparison of torque characteristics

Comparison of the two characteristic curves clearly shows the higher torques delivered by the LSH motor as against the LST motor. The standstill torque of the LSH is significantly higher than the torque delivered by the LST.

The magnets of the LSH motor also permit higher maximum torque values than the magnets of the LST motor.

Despite all these advantages, not all applications can be covered by the LSH motor:

Because of the high number of pole pairs on the LSH motor, it has a high nominal frequency. This means that the iron losses increase disproportionately in comparison to speed. This can clearly be seen in the sharply falling torque characteristic of the LSH.

This comparison shows that it is your application which determines the right type of motor!



If a high dynamic response is required, the LSH motor scores well. In standard applications, the high power density of the LSH motor is conclusive. In addition the LSH motor wins on a price comparison and by virtue of its compact length.



Because of its 6-pole design, the LST motor is suited primarily for applications with nominal speeds greater than 3000 rpm. Furthermore, the LST motor is the right one for extreme overloads under standstill conditions (e.g.: power press applications). When a desired moment of inertia must be matched, the LST motor can achieve better control characteristics than the more dynamic LSH motor.

Basic configuration of servomotors

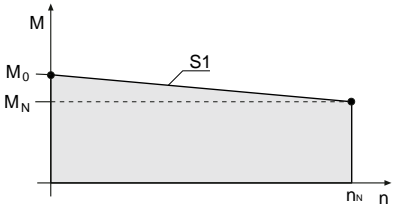
Characteristic	Synchronous servomotor LSx
Machine type	Permanent-field synchronous servomotor
Magnet material	Neodymium-iron-boron
Design (DIN 42948)	B5, V1, V3
Index of Protection (DIN 40050)	IP64, IP54 to EN 60034-5 (rotating machines), IP65 optionally available
Insulating material class	Insulating material class F to VDE 0530, winding overtemperature $\Delta t = 100\text{ }^\circ\text{C}$, ambient temperature $t_u = -20\text{ }^\circ\text{C}$ to $+40\text{ }^\circ\text{C}$, non-condensing!!!
Paint finish	RAL 9005 (matt black)
Shaft end on the A side	Plain shaft (drive key and keyway DIN 6885, tolerance band k6 as option)
Smooth-running accuracy, coaxiality and concentricity to DIN 42955	Tolerance N (normal), tolerance R (reduced) on request
Thermal motor monitoring	DIN-PTC in a stator winding
<p>In order to avoid thermal overloading of the motor, the effective load torque at medium speed should not be higher than the S1 characteristic line.</p> 	
Torque load	$M_{\text{eff}} = \frac{\sum (M_n^2 \times t_n)}{t_{\text{ges}}}$ $\bar{n} = \frac{\sum (n_n \times t_n)}{t_{\text{ges}}}$
Maximum pulse torque	Typically 2 to 4 times nominal torque for max. 0.2 s, depending on controller assignment
Vibration severity to ISO 2373	Grade N, optionally R
Bearing service life	The average bearing life under nominal conditions ($M_{\text{max}} \leq M_N$) is 20,000 h
Type of connection of motor, thermistor and holding brake	via plug-in terminals
Type of connection of encoder system	Signal plug (mating plug not supplied)

Cooling

The specified nominal data relate to a max. ambient temperature of 40 °C and mounting of the motor on an aluminium plate with a max. temperature of 40 °C and installed at an altitude of max. 1000 m above MSL.

Minimum mounting face:
2.5 × area of the motor flange

Thickness of the mounting face:
min. 10 mm

If the motor is mounted with insulation (no heat dissipation via the flange) the nominal torque must be reduced.

For installation at altitudes > 1000 m above MSL the power output must be reduced by 1 % per 100 metres. The maximum installation altitude is 4000 metres.

At ambient temperatures > 40 °C the power output must be reduced by 1 % per 1 °C. The maximum ambient temperature is 50 °C.

Order code: Lust synchronous motors LSx

Example LSH-074-1-30-560

Article designation →	LSX	-	074	-	1	-	30	-	560	/	[Options] [if available]
Lust synchronous motor series T or H	T H										
Edge dimensions of motor in mm (not flange dimensions)			050 074 097 127 158 190 220								
Length					2 3 4 5						
Nominal speed (x100)							30 45				
DC link voltage of controller (VDC)									24 48 320 560		
Ordering options (in sequence)											T0, T1, T4; B, P, X, K, 1R, 3R, 5R, G3, G5, G6.1M, G6.1S, G6.2M, G6.2S G12.1S, G12.1M, G12.2S, G12.2M

- Standard definition
- Plain motor shaft (no keyway)
 - Resolver with 1 pole pair
 - IP64 to DIN 40050 except flange
 - IP54 to DIN VDE 0530-5 / EN 60034-5 (rotating machines)
 - Resolver plug straight, outgoing
 - Power plug straight, outgoing
 - Double basic insulation (winding and PTC)

- Options:
- T0 (Thermal protection: thermoswitch / e.g. Klixon)
 - T1 (DIN-PTC double basic insulation) is specified as standard!
 - T4 (Thermal protection: KTY84-130)
 - B Holding brake 24 VDC
 - P Drive key to DIN 6885 sheet 1
 - X Custom design (e.g. special flange / shaft / housing / encoder, etc.)
 - K Cable 1 m with unterminated ends (standard LST-037)

Ordering options	Description	Interface	Oscillations, analog	Single-turn info	Multi-turn info	Compatible with
1R	Resolver with 1 pole pair	analog	1	14 bit	-	all LSx
3R	Resolver with 3 pole pairs	analog	3	-	-	from LSx-50
5R	Resolver with 5 pole pairs	analog	5	-	-	from LSH-74
G3	Multi-turn absolute value encoder EQN 1325	analog and SSI	2048	13 bit	12 bit	from LSx-074
G5	Single-turn absolute value encoder ECN 1313	analog and SSI	2048	13 bit	-	from LSx-074
G6.1S	Single-turn absolute value encoder SRS 50	analog and Hiperface	1024	15 bit	-	from LSx-074
G6.1M	Multi-turn absolute value encoder SRM 50	analog and Hiperface	1024	15 bit	12 bit	from LSx-074
G6.2S	Single-turn absolute value encoder SRS 36	analog and Hiperface	128	15 bit	-	from LSx-050
G6.2M	Multi-turn absolute value encoder SKM 36	analog and Hiperface	128	15 bit	12 bit	from LSx-050
G12.1S	Single-turn absolute value encoder ECN 1313	analog and Endat 2.1	2048	13 bit	-	from LSx-074
G12.1M	Multi-turn absolute value encoder EQN 1325	analog and Endat 2.1	2048	13 bit	12 bit	from LSx-074
G12.2S	Single-turn absolute value encoder EQN 1113	analog and Endat 2.1	512	13 bit	-	from LSx-050
G12.2M	Multi-turn absolute value encoder EQN 1125	analog and Endat 2.1	512	13 bit	12 bit	from LSx-050

Ordering example:

Motor LSH-074-1-30-560 with (DIN-PTC, brake, keyway, angled flange sockets and SRS50 encoder)
 = LSH-074-1-30-560 / T1, B, P, S4, G6.1S

Typical M-n characteristic of servomotors

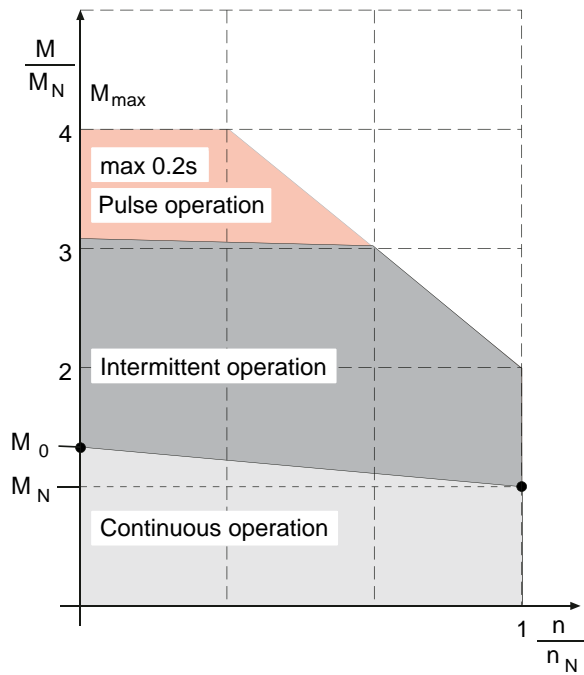

M-n characteristic for synchronous motors

Term	Explanation
M_0 standstill torque	Thermally limited torque of the motor at standstill. The motor can deliver this torque for an unlimited length of time.
I_0 standstill current	Effective value of the motor phase current required to generate the standstill torque.
M_N nominal torque	Thermally limited torque of the motor at nominal speed n_N .
I_N rated current	Effective value of the motor phase current required to generate the nominal torque.
P_N rated power	Continuous power output of the motor at the nominal operation point (M_N, n_N) at rated current I_N and rated voltage U_N .
M_{MAX}, I_{MAX} limit characteristic	A maximum of four times the rated current may be applied to the motors.

Permissible axial and lateral forces

Sizes	Radial force F_{Rm} [N] at speed n [rpm]					Axial force F_{Am} [N] at speed n [rpm]					F_G [N]
	1000	2000	3000	4500	6000	1000	2000	3000	4500	6000	
LST-037	230	185	160	140	130	44	35	31	27	24	2
LST-037/B	130	100	90	77	70	24	19	17	15	13	2
LSH-050	310	250	220	190	170	60	50	42	36	32	2
LST-050	325	260	225	195	175	62	50	43	37	34	2
LSH-074	480	380	330	290	260	90	70	63	55	50	6
LST-074	535	425	370	325	295	100	80	70	60	55	6
LSH-097	850	680	600	520	470	160	130	115	100	90	15
LST-097	920	730	640	560	510	175	140	120	105	95	18
LSH-127	970	770	670	590	530	185	145	125	110	100	34
LST-127	1000	790	690	600	550	190	150	130	115	105	34
LST-158	1020	810	710	620	560	195	155	135	120	110	60
LST-190	1950	1550	1350	1170	1070	370	290	260	225	200	100
LST-220	2500	1950	1700	1490	1350	470	370	320	280	260	200

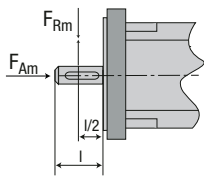

The table indicates the max. permissible lateral force (radial force F_{Rm}) at the point of application $l/2$ and the max. permissible axial force F_{Am} for a service life of 20,000 h. Lateral forces applied other than in the middle of the shaft end can simply be translated to allow for the changed leverage ratios.

Either the permissible radial force or the axial force may act on the motor shaft!

Technical data design

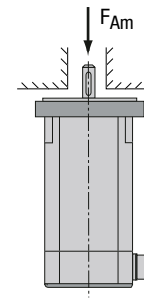
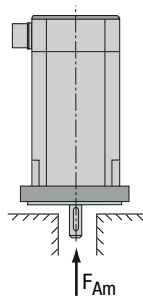
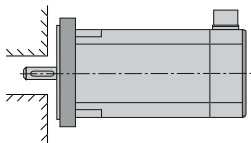

Design	B5	V1	V3
Shaft	Free shaft end	Free shaft end at bottom	Free shaft end at top
Attachment	Flange mounting, access from housing side	Flange mounting at bottom, access from housing side	Flange mounting at top, access from housing side



Note: If mounted vertically (V1) the permissible axial forces (F_{Am}) are applicable. If mounted vertically upwards (V3) the permissible axial forces are reduced by the force due to the weight of the rotor (F_G).

Connections

1



LSH-074-1-30-560/S4*, G3*
 plug arrangement ————
 pin assignment ————
 *Example

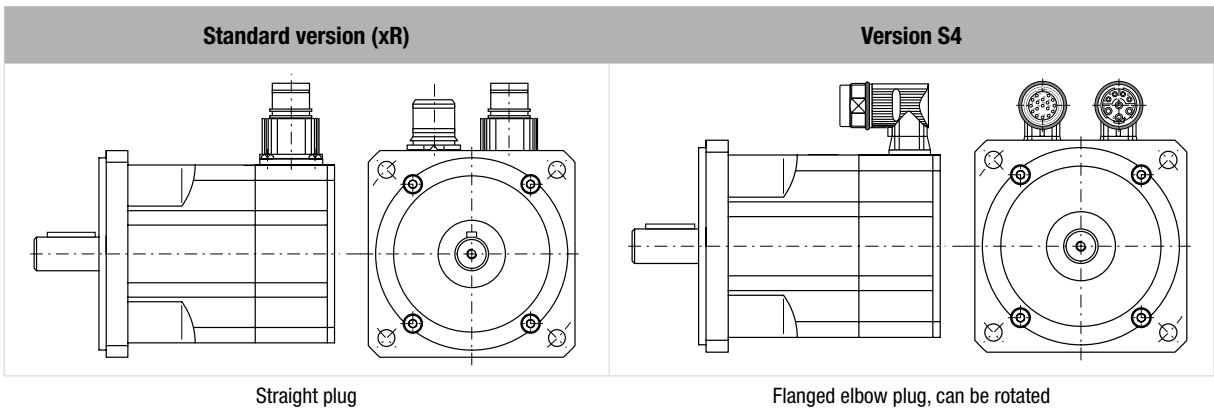

Power connection

8-pin connector
 Contact pins
 for contact 1 ... 4 \varnothing 2 mm
 for contact A ... D \varnothing 1 mm

Pin	Des.	Designation
1	U	Motor phase U
2	PE	PE
3	W	Motor phase W
4	V	Motor phase V
A	Brake +	Brake +
B	Brake -	Brake -
C	n. c.	not assigned
D	n. c.	not assigned

Encoder connection

12-pin connector
 Contact pins \varnothing 1 mm

Pin	Des.	Designation	Version
1	Cos+	(S1)	Standard, resolver 1-pole pair single turn absolute encoder
2	COS-	(S3)	
3	SIN+	(S2)	
4	SIN-	(S4)	
6	REF+	(R1)	
7	REF-	(R2)	
11	PTC+	Motor PTC	
12	PTC-	Motor PTC	
5, 8, 9, 10	n. c.	not assigned	

Power connection

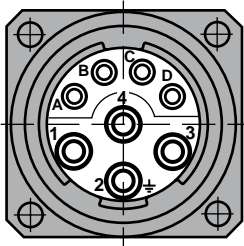

8-pin connector
Contact pins
for contact 1 ... 4 \varnothing 2 mm
for contact A ... D \varnothing 1 mm

Pin	Des.	Designation
1	U	Motor phase U
2	PE	PE
3	W	Motor phase W
4	V	Motor phase V
A	Brake +	Brake +
B	Brake -	Brake -
C	PTC+	Motor PTC
D	PTC-	Motor PTC

Encoder connection (Gx)

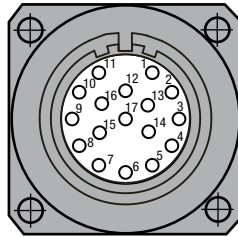

17-pin connector
Contact pins
 \varnothing 1 mm

Pin	Des.	Designation	Version
1	A+		G12.x high resolution EnDat2.1 encoder, multi-turn (G12.xM) or single-turn (G12.xS) G3/G5, high resolution SSI encoder, multi-turn (G3) or single-turn (G5)
2	A-		
3	B+		
4	B-		
7	GND	0 V	
8	Up	+5 V/150 mA	
10	DATA+		
11	DATA-		
12	CLOCK+		
13	CLOCK-		
14	PTC+	Motor PTC	
15	PTC-	Motor PTC	
16	Up	Sense lead	
17	GND	Sense lead	
5, 6, 9	n. c.	not assigned	

Pin	Des.	Designation	Version
1	A+		G6.x, high resolution Hiperface encoder, single-turn (G6.xS) or multi-turn (G6.xM)
2	A-		
3	B+		
4	B-		
7	GND	0 V	
9	Uv	+7 ... 12 V/100 mA	
10	DATA+	RS485 data	
11	DATA-	RS485 data	
14	CLOCK+	Motor PTC	
15	CLOCK-	Motor PTC	
5, 6, 8, 12, 13, 16, 17	n. c.	not assigned	

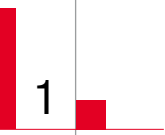

LSH servomotors overview

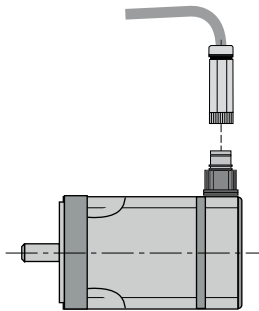

Type	U _{DC}	Page
LSH-050	320 V	2 - 2
LSH-074	320 V	2 - 6
	560 V	2 - 10
LSH-097	320 V	2 - 14
	560 V	2 - 18
LSH-127	560 V	2 - 22

The LSH motor - the power pack

Using a completely new winding technology known as concentrated winding, the new LSH generation of motors improves power density by between 30 % and 70 % compared with conventional technologies.

For the user this means up 100 % improvement in dynamic response and significantly reduced space requirements combined with smooth running.

Technical data	Standstill torque	Nominal torque	Rated current at 560 V	Rated current at 320 V	Nominal speed
Motor	M ₀ [Nm]	M _N [Nm]	I _N [A]	I _N [A]	n _N [rpm]
LSH-050-1 ¹⁾	0.26	0.24	-	0.68	4500
LSH-050-2 ¹⁾	0.53	0.45	-	1.11	4500
LSH-050-3 ¹⁾	0.74	0.67	-	1.55	4500
LSH-050-4 ¹⁾	0.95	0.84	-	1.90	4500
LSH-074-1 ²⁾	0.95	0.86	1.28	1.43	3000
LSH-074-2 ²⁾	1.90	1.60	1.46	2.40	3000
LSH-074-3 ²⁾	3.30	2.90	2.30	4.00	3000
LSH-074-4 ²⁾	4.20	3.10	2.30	3.70	3000
LSH-097-1 ²⁾	4.10	3.20	2.80	5.00	3000
LSH-097-2 ²⁾	6.30	4.60	3.60	7.00	3000
LSH-097-3 ²⁾	8.60	6.10	4.80	8.3	3000
LSH-127-1 ³⁾	11.60	8.40	7.90	-	3000
LSH-127-2 ³⁾	14.90	10.90	9.60	-	3000
LSH-127-3 ³⁾	18.70	14.30	13.10	-	3000
LSH-127-4 ³⁾	27.30	21.00	14.90	-	3000

1) DC link voltage 320 V
 2) DC link voltage 320 V / 560 V
 3) DC link voltage 60 V

Motor type LSH-050 ($U_{ZK} = 320 \text{ V}$)



Motor length [mm]	K (with resolver)	K (with optical encoder G12.2x)	K (with optical encoder G6.2x)	Additional length for version LSX-xxx-...,B (brake)
LSH-050-1-45-320	67	130.5	98	38
LSH-050-2-45-320	82	145.5	113	38
LSH-050-3-45-320	97	160.5	128	38
LSH-050-4-45-320	112	175.5	143	38

Dimensional drawing

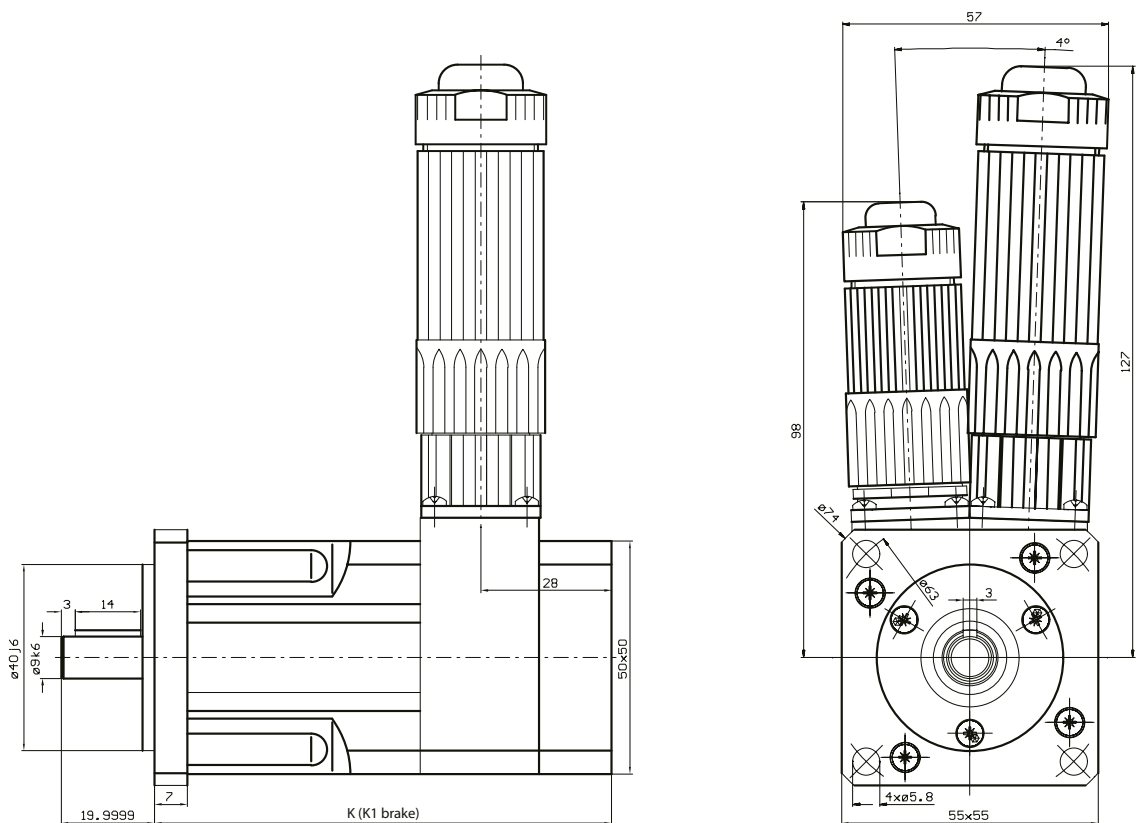

Technical data	Symbols	LSH-050-1-45-320	LSH-050-2-45-320	LSH-050-3-45-320	LSH-050-4-45-320
Nominal speed	n_n	4500 rpm	4500 rpm	4500 rpm	4500 rpm
Nominal frequency	f_N	225 Hz	225 Hz	225 Hz	225 Hz
DC link voltage (controller)	U_{dc}	320 V	320 V	320 V	320 V
Rated voltage	U_n	200 V	200 V	200 V	200 V
Nominal torque	M_n	0.24 Nm	0.45 Nm	0.67 Nm	0.84 Nm
Rated current	I_n	0.68 A	1.11 A	1.55 A	1.90 A
Power	P	0.11 kW	0.21 kW	0.31 kW	0.40 kW
Standstill torque	M_0	0.26 Nm	0.53 Nm	0.74 Nm	0.95 Nm
Standstill current	I_0	0.70 A	1.26 A	1.66 A	2.1 A
Maximum permissible torque	M_{max}	1.0 Nm	2.0 Nm	2.8 Nm	3.6 Nm
Maximum permissible current	I_{max}	2.9 A	5.1 A	6.7 A	8.5 A
Maximum permissible speed	n_{max}	12000 rpm	12000 rpm	12000 rpm	12000 rpm
Voltage constant	K_E	22.5 V/1000	25.5 V/1000	27.0 V/1000	27.5 V/1000
Torque constant	K_T	0.37 Nm/A	0.42 Nm/A	0.45 Nm/A	0.45 Nm/A
Winding resistance (two phases)	R_{2ph}	33.1 Ω	16.4 Ω	11.1 Ω	8.4 Ω
Winding inductance (two phases)	L_{2ph}	51 mH	32.7 mH	24.5 mH	19.4 mH
No-load speed	n_0	8890 rpm	7840 rpm	7410 rpm	7250 rpm
Electrical time constant	T_{el}	1.5 ms	2.0 ms	2.2 ms	2.3 ms
Thermal time constant	T_{th}	13 min.	15 min.	20 min.	22 min.
Moment of inertia of the rotor	J	0.000006 kgm ²	0.000008 kgm ²	0.00001 kgm ²	0.000012 kgm ²
Mass	m	0.75 kg	0.92 kg	1.1 kg	1.26 kg
Brake (optional)					
Rated voltage $\pm 10\%$	U_N	24 V $\pm 10\%$			
Rated current at 20 °C for release	I_N	0.46 A			
Permissible maximum speed	n_{max}	10,000 rpm			
Permissible frictional work	W_R	0.41 x 10 ⁶ Ws			
Moment of inertia	J_B	0.000007 kgm ²			
Mass	m	0.15 kg			
Braking torque	M_H	2 Nm			

Motor type LSH-050 ($U_{ZK} = 320 \text{ V}$)

Explanation of characteristic lines:

The upper characteristic line (M_{max}) describes the short-time maximum possible torque at the corresponding rotation speed (important for dynamic processes).

The lower characteristic line (M_{nenn}) shows the thermally permissible continuous torque.

LSH-050-1-45-320

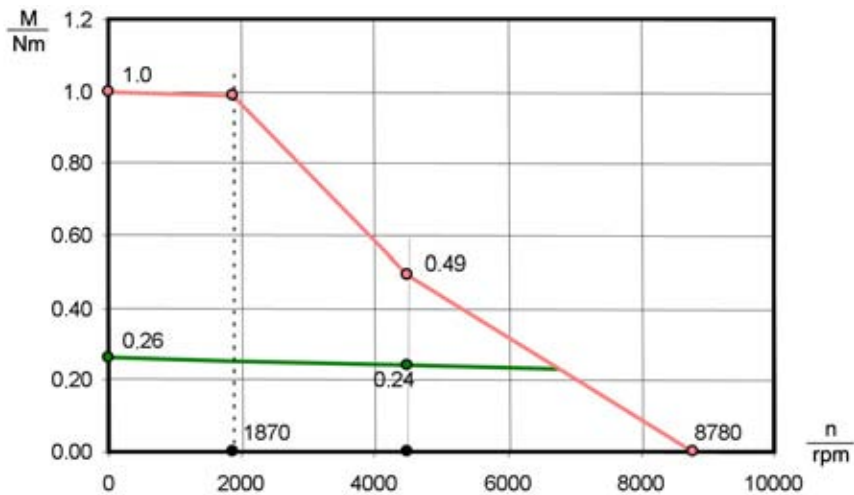

LSH-050-2-45-320

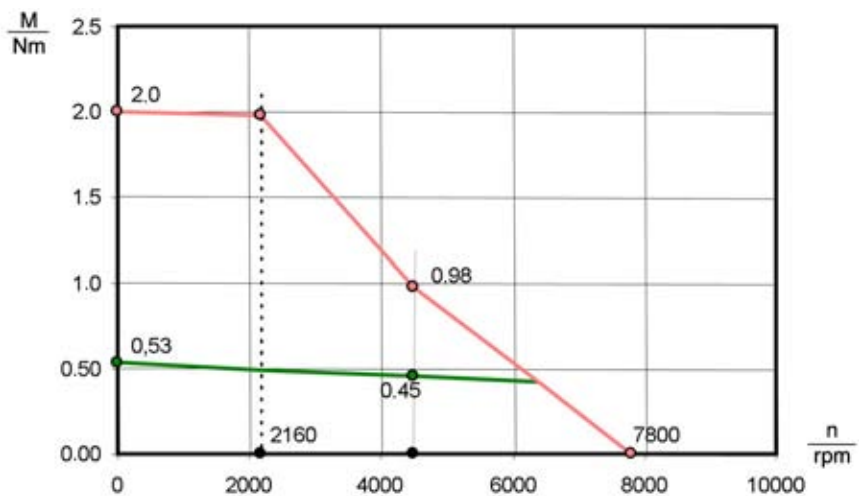

LSH-050-3-45-320

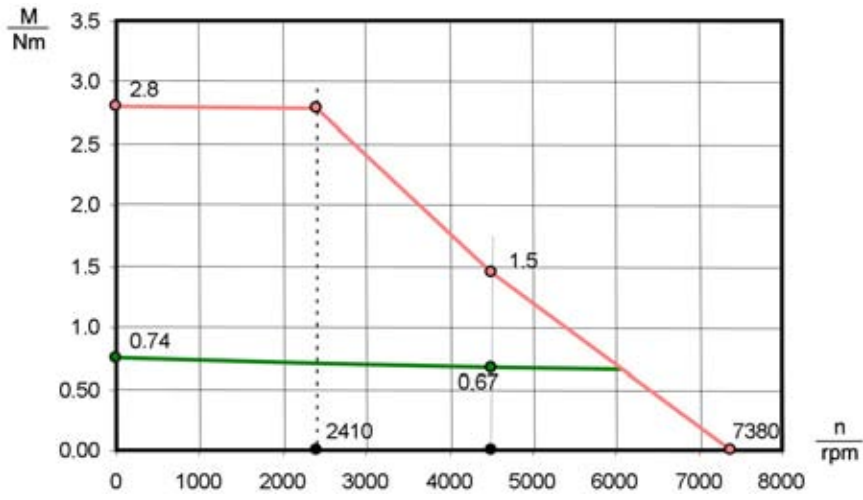

LSH-050-4-45-320

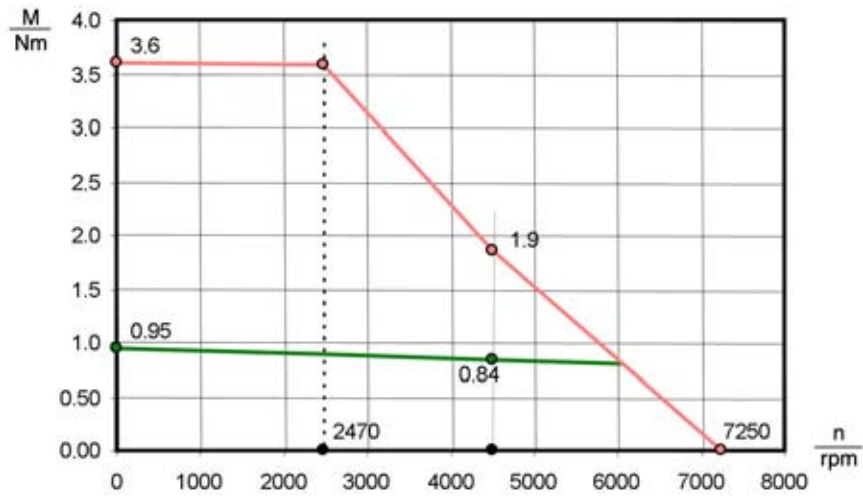

Motor type LSH-074 ($U_{ZK} = 320 \text{ V}$)



Motor length [mm]	K (with resolver)	K (with optical encoder G3, G5, G12.x)	K (with optical encoder G6.x)	Additional length for version LSX-xxx-...,B (brake)
LSH-074-1-30-320	96	137	115.5	42
LSH-074-2-30-320	114	155	133.5	42
LSH-074-3-30-320	150	191	169.5	42
LSH-074-4-30-320	186	227	205.5	42

Dimensional drawing

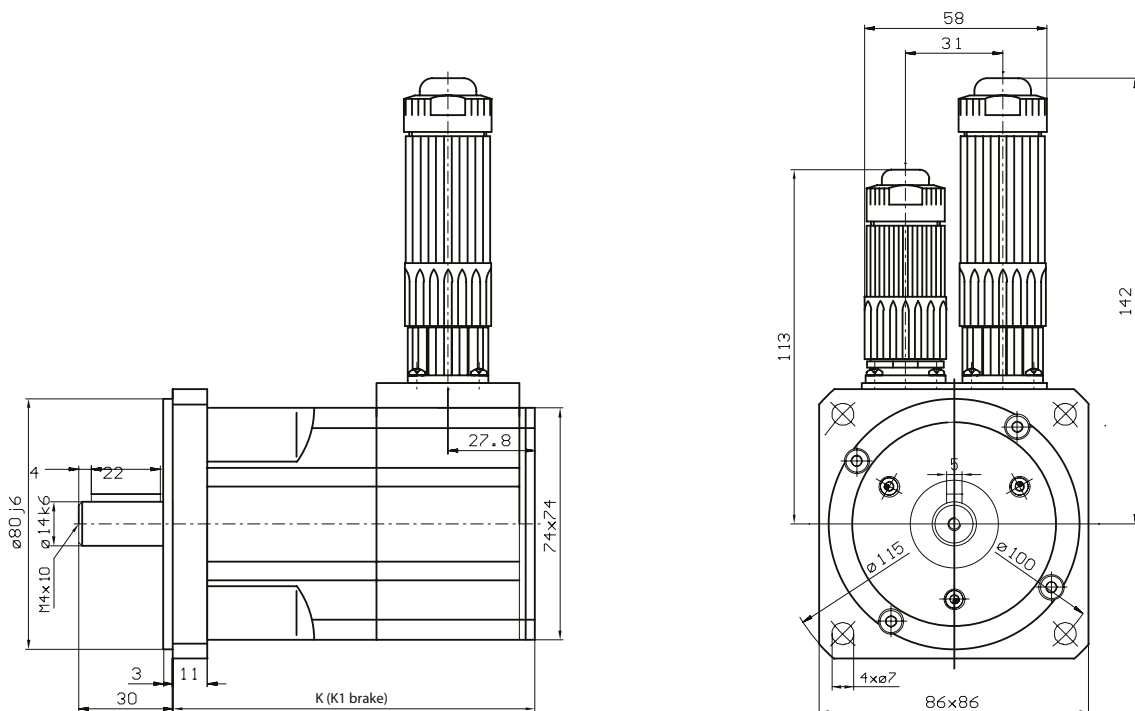

Technical data	Symbols	LSH-074-1-30-320	LSH-074-2-30-320	LSH-074-3-30-320	LSH-074-4-30-320
Nominal speed	n_n	3000 rpm	3000 rpm	3000 rpm	3000 rpm
Nominal frequency	f_N	250 Hz	250 Hz	250 Hz	250 Hz
DC link voltage (controller)	U_{dc}	320 V	320 V	320 V	320 V
Rated voltage	U_n	200 V	200 V	200 V	200 V
Nominal torque	M_n	0.86 Nm	1.6 Nm	2.9 Nm	3.1 Nm
Rated current	I_n	1.43 A	2.4 A	4.0 A	3.7 A
Power	P	0.27 kW	0.5 kW	0.91 kW	0.97 kW
Standstill torque	M_0	0.95 Nm	1.9 Nm	3.3 Nm	4.2 Nm
Standstill current	I_0	1.47 A	2.8 A	4.3 A	4.8 A
Maximum permissible torque	M_{max}	2.4 Nm	5.2 Nm	9.5 Nm	12.3 Nm
Maximum permissible current	I_{max}	5.4 A	11.1 A	18.6 A	21.0 A
Maximum permissible speed	n_{max}	12000 rpm	12000 rpm	12000 rpm	12000 rpm
Voltage constant	K_E	39.0 V/1000	41.5 V/1000	46.0 V/1000	53.0 V/1000
Torque constant	K_T	0.65 Nm/A	0.69 Nm/A	0.76 Nm/A	0.88 Nm/A
Winding resistance (two phases)	R_{2ph}	9.9 Ω	4.0 Ω	2.2 Ω	1.77 Ω
Winding inductance (two phases)	L_{2ph}	30.6 mH	15.4 mH	9.8 mH	10.0 mH
No-load speed	n_0	5080 rpm	4800 rpm	4340 rpm	3760 rpm
Electrical time constant	T_{el}	3.1 ms	3.9 ms	4.5 ms	5.6 ms
Thermal time constant	T_{th}	25 min.	30 min.	33 min.	36 min.
Moment of inertia of the rotor	J	0.000050 kgm ²	0.000070 kgm ²	0.00011 kgm ²	0.00015 kgm ²
Mass	m	1.52 kg	2.09 kg	3.22 kg	4.35 kg
Brake (optional)					
Rated voltage $\pm 10\%$	U_N	24 V $\pm 10\%$			
Rated current at 20 °C for release	I_N	0.5 A			
Permissible maximum speed	n_{max}	10,000 rpm			
Permissible frictional work	W_R	0.58 x10 ⁶ Ws			
Moment of inertia	J_B	0.000018 kgm ²			
Mass	m	0.3 kg			
Braking torque	M_H	4.5 Nm			

Motor type LSH-074 ($U_{ZK} = 320 \text{ V}$)

Explanation of characteristic lines:

The upper characteristic line (M_{max}) describes the short-time maximum possible torque at the corresponding rotation speed (important for dynamic processes).

The lower characteristic line (M_{nenn}) shows the thermally permissible continuous torque.

LSH-074-1-30-320

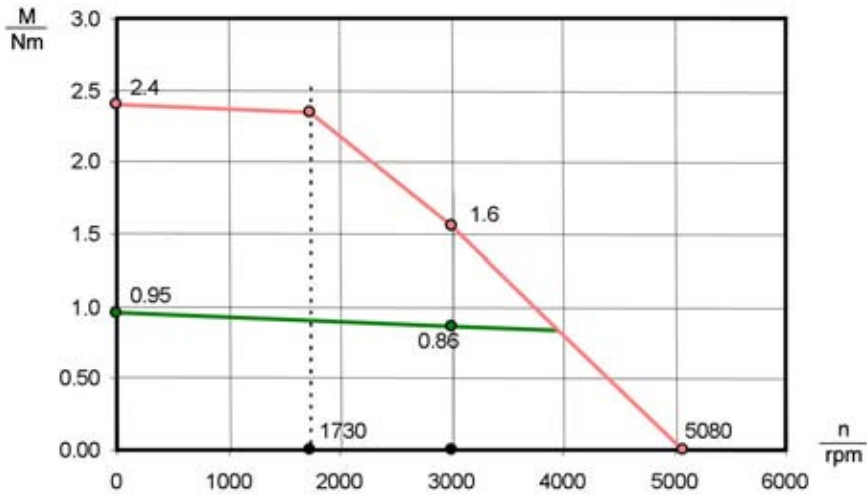

LSH-074-2-30-320

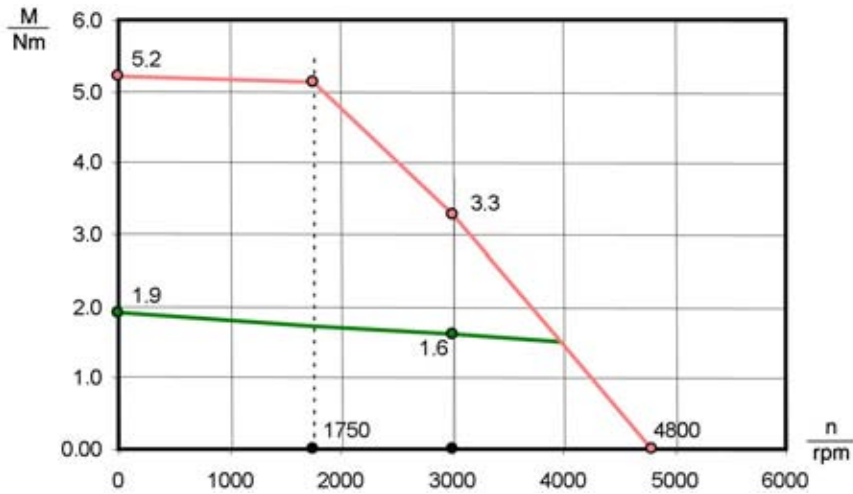

LSH-074-3-30-320

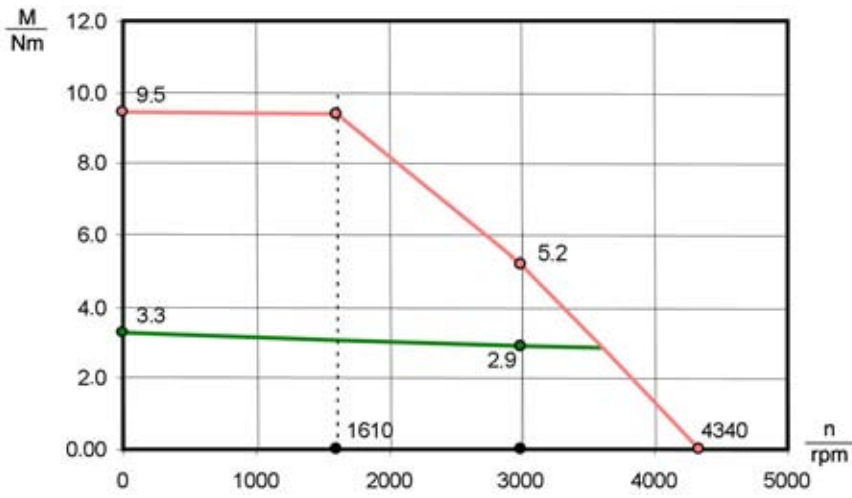

LSH-074-4-30-320

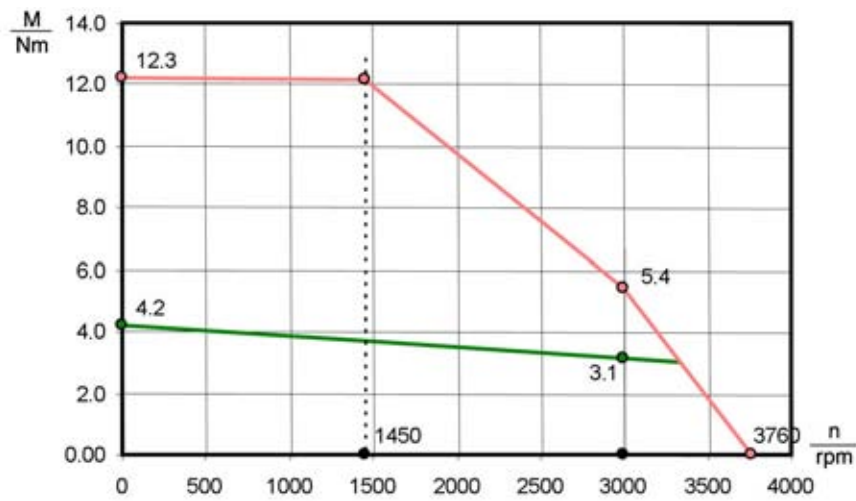

Motor type LSH-074 ($U_{ZK} = 560 \text{ V}$)



Motor length [mm]	K (with resolver)	K (with optical encoder G3, G5, G12.x)	K (with optical encoder G6.x)	Additional length for version LSX-xxx-...,B (brake)
LSH-074-1-30-560	96	137	115.5	42
LSH-074-2-30-560	114	155	133.5	42
LSH-074-3-30-560	150	191	169.5	42
LSH-074-4-30-560	186	227	205.5	42

Dimensional drawing

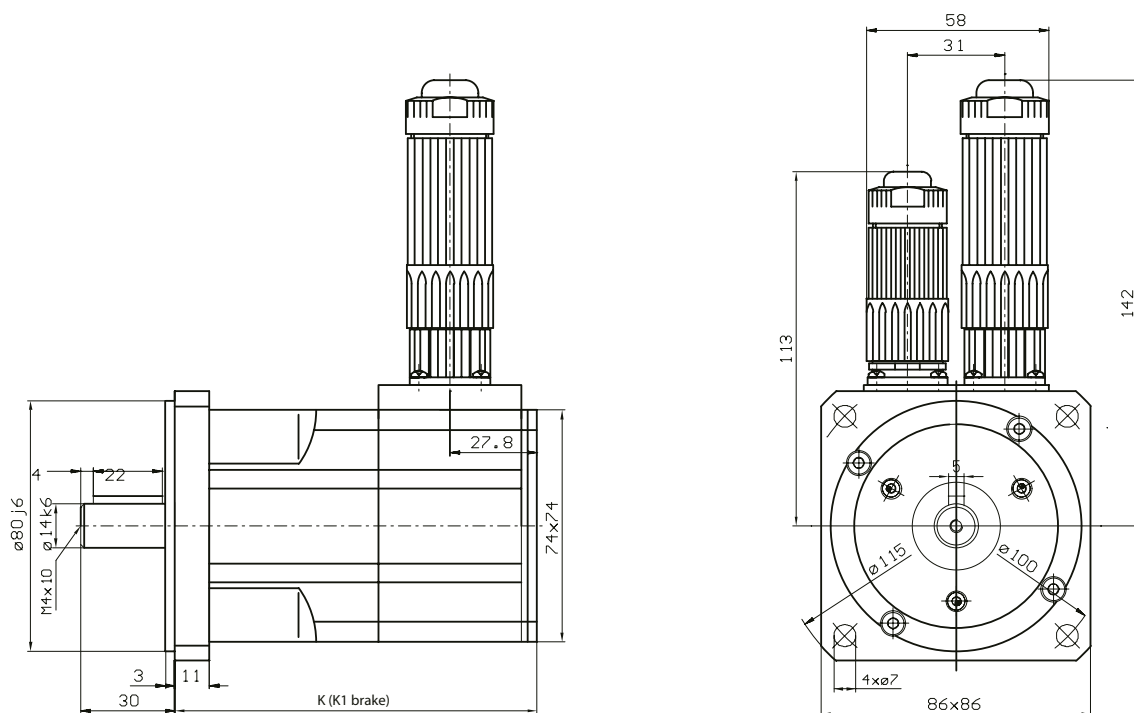

Technical data	Symbols	LSH-074-1-30-560	LSH-074-2-30-560	LSH-074-3-30-560	LSH-074-4-30-560
Nominal speed	n_n	3000 rpm	3000 rpm	3000 rpm	3000 rpm
Nominal frequency	f_N	250 Hz	250 Hz	250 Hz	250 Hz
DC link voltage (controller)	U_{dc}	560 V	560 V	560 V	560 V
Rated voltage	U_n	330 V	330 V	330 V	330 V
Nominal torque	M_n	0.86 Nm	1.6 Nm	2.9 Nm	3.1 Nm
Rated current	I_n	1.28 A	1.46 A	2.3 A	2.3 A
Power	P	0.27 kW	0.5 kW	0.91 kW	0.97 kW
Standstill torque	M_0	0.95 Nm	1.9 Nm	3.3 Nm	4.2 Nm
Standstill current	I_0	1.32 A	1.66 A	2.4 A	3.0 A
Maximum permissible torque	M_{max}	2.4 Nm	5.2 Nm	9.5 Nm	12.3 Nm
Maximum permissible current	I_{max}	4.9 A	6.7 A	10.6 A	12.9 A
Maximum permissible speed	n_{max}	12000 rpm	12000 rpm	12000 rpm	12000 rpm
Voltage constant	K_E	43.5V/1000	69.0 V/1000	81.0 V/1000	86.0 V/1000
Torque constant	K_T	0.72 Nm/A	1.14 Nm/A	1.34 Nm/A	1.42 Nm/A
Winding resistance (two phases)	R_{2ph}	12.6 Ω	11.6 Ω	6.5 Ω	4.6 Ω
Winding inductance (two phases)	L_{2ph}	38.0 mH	42.3 mH	30.6 mH	26.1 mH
No-load speed	n_0	7520 rpm	4770 rpm	4060 rpm	3830 rpm
Electrical time constant	T_{el}	3.0 ms	3.6 ms	4.7 ms	5.7 ms
Thermal time constant	T_{th}	25 min.	30 min.	33 min.	36 min.
Moment of inertia of the rotor	J	0.000050 kgm ²	0.000070 kgm ²	0.00011 kgm ²	0.00015 kgm ²
Mass	m	1.52 kg	2.09 kg	3.22 kg	4.35 kg
Brake (optional)					
Rated voltage $\pm 10\%$	U_N	24 V $\pm 10\%$			
Rated current at 20 °C for release	I_N	0.5 A			
Permissible maximum speed	n_{max}	10,000 rpm			
Permissible frictional work	W_R	0.58 x 10 ⁶ Ws			
Moment of inertia	J_B	0.000018 kgm ²			
Mass	m	0.3 kg			
Braking torque	M_H	4.5 Nm			

Motor type LSH-074 ($U_{ZK} = 560 \text{ V}$)

Explanation of characteristic lines:

The upper characteristic line (M_{max}) describes the short-time maximum possible torque at the corresponding rotation speed (important for dynamic processes).

The lower characteristic line (M_{nenn}) shows the thermally permissible continuous torque.

2

LSH-074-1-30-560

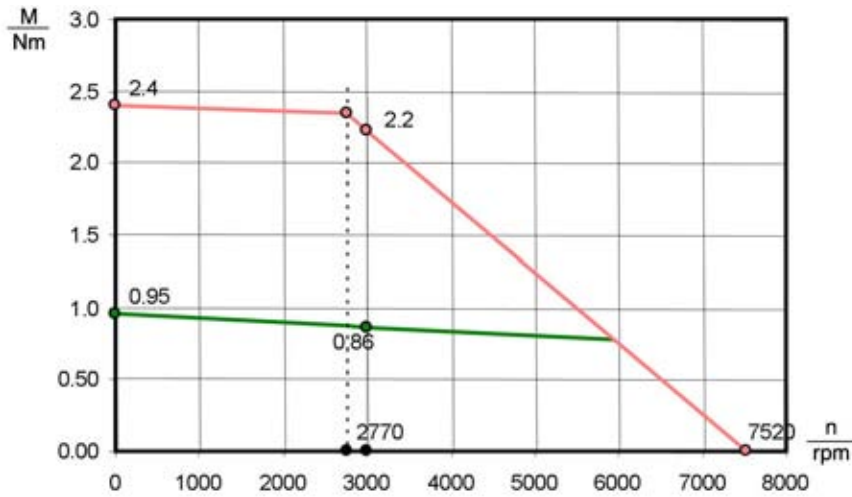

LSH-074-2-30-560

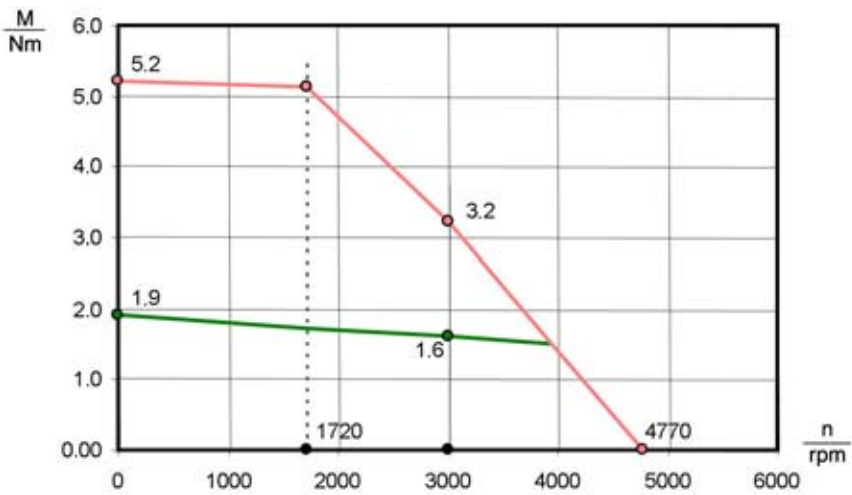

LSH-074-3-30-560

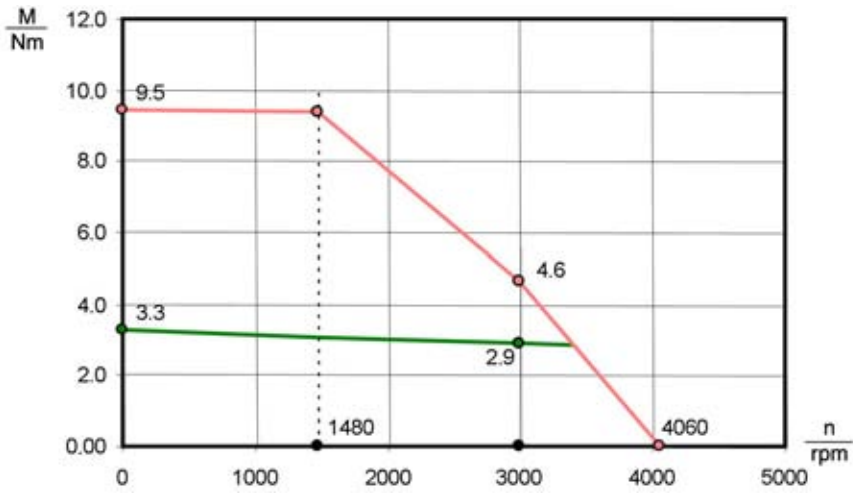

LSH-074-4-30-560

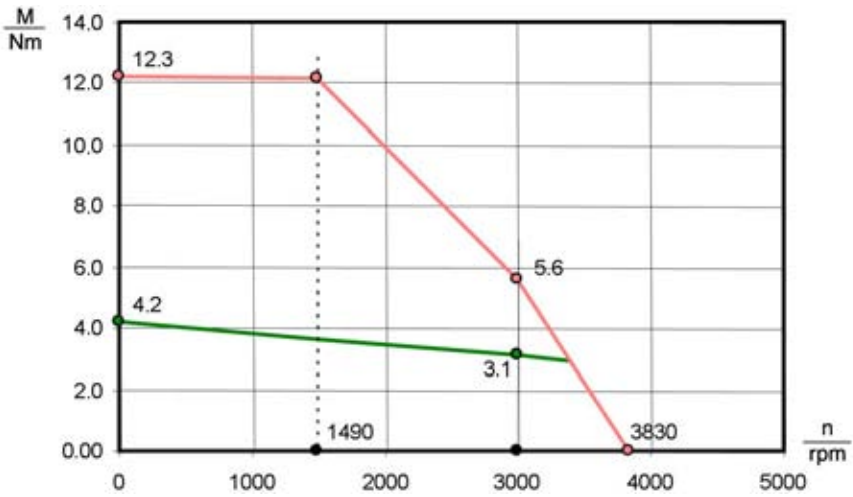

Motor type LSH-097 ($U_{ZK} = 320 \text{ V}$)



Motor length [mm]	K (with resolver)	K (with optical encoder G3, G5, G12.x)	K (with optical encoder G6.x)	Additional length for version LSX-xxx-...,B (brake)
LSH-097-1-30-320	129	166	150	41
LSH-097-2-30-320	159	196	180	41
LSH-097-3-30-320	189	226	210	41

Dimensional drawing

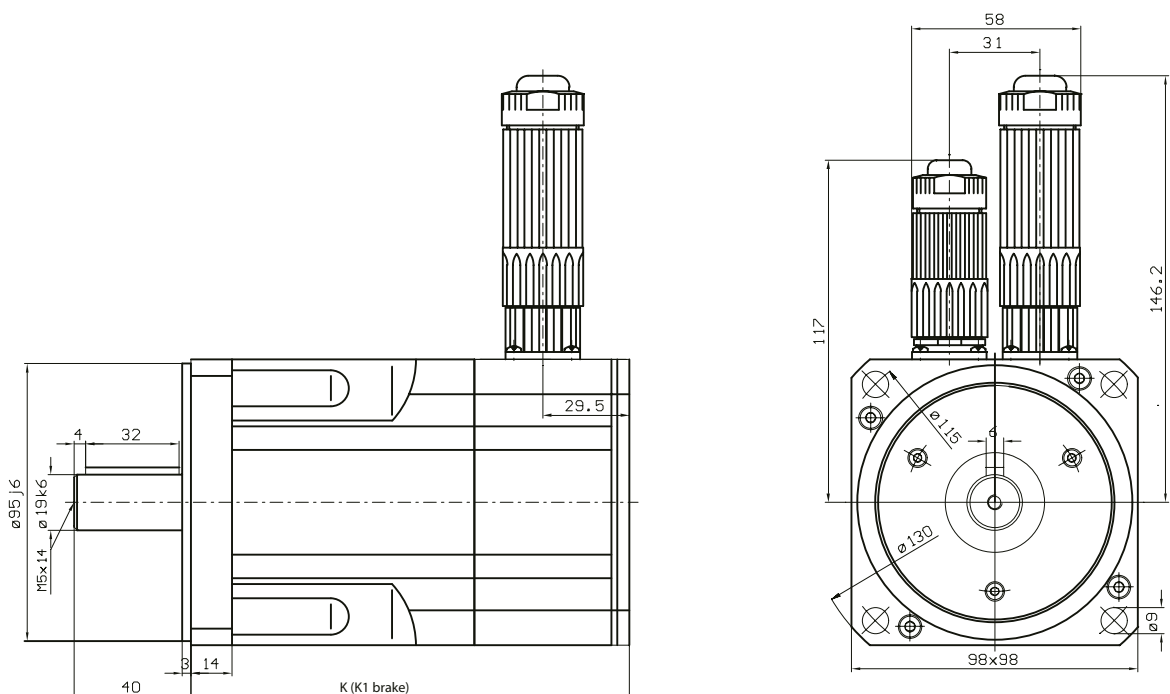

Technical data	Symbols	LSH-097-1-30-320	LSH-097-2-30-320	LSH-097-3-30-320
Nominal speed	n_n	3000 rpm	3000 rpm	3000 rpm
Nominal frequency	f_N	250 Hz	250 Hz	250 Hz
DC link voltage (controller)	U_{dc}	320 V	320 V	320 V
Rated voltage	U_n	200 V	200 V	200 V
Nominal torque	M_n	3.2 Nm	4.6 Nm	6.1 Nm
Rated current	I_n	5.0 A	7.0 A	8.3 A
Power	P	1.0 kW	1.44 kW	1.9 kW
Standstill torque	M_0	4.1 Nm	6.3 Nm	8.6 Nm
Standstill current	I_0	6.0 A	9.2 A	11.2 A
Maximum permissible torque	M_{max}	11.1 Nm	18.5 Nm	27.0 Nm
Maximum permissible current	I_{max}	24.0 A	40.0 A	53.0 A
Maximum permissible speed	n_{max}	9000 rpm	9000 rpm	9000 rpm
Voltage constant	K_E	40.5 V/1000	41.5 V/1000	46.5 V/1000
Torque constant	K_T	0.67 Nm/A	0.69 Nm/A	0.77 Nm/A
Winding resistance (two phases)	R_{2ph}	1.24 Ω	0.7 Ω	0.59 Ω
Winding inductance (two phases)	L_{2ph}	10.6 mH	6.9 mH	6.2 mH
No-load speed	n_0	4920 rpm	4810 rpm	4290 rpm
Electrical time constant	T_{el}	8.5 ms	9.9 ms	10.5 ms
Thermal time constant	T_{th}	29 min.	31 min.	33 min.
Moment of inertia of the rotor	J	0.00017 kgm ²	0.00026 kgm ²	0.00035 kgm ²
Mass	m	4.28 kg	5.34 kg	6.96 kg
Brake (optional)				
Rated voltage $\pm 10\%$	U_N		24 V $\pm 10\%$	
Rated current at 20 °C for release	I_N		0.75 A	
Permissible maximum speed	n_{max}		10,000 rpm	
Permissible frictional work	W_R		0.89 x 10 ⁶ Ws	
Moment of inertia	J_B		0.000054 kgm ²	
Mass	m		0.46 kg	
Braking torque	M_H		9.0 Nm	

Motor type LSH-097 ($U_{ZK} = 320 \text{ V}$)

Explanation of characteristic lines:

The upper characteristic line (M_{max}) describes the short-time maximum possible torque at the corresponding rotation speed (important for dynamic processes).

The lower characteristic line (M_{nenn}) shows the thermally permissible continuous torque.

2

LSH-097-1-30-320

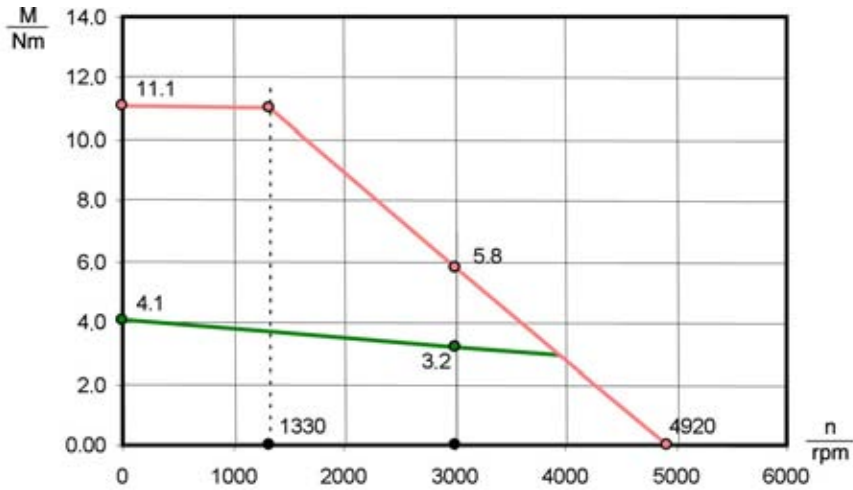

LSH-097-2-30-320

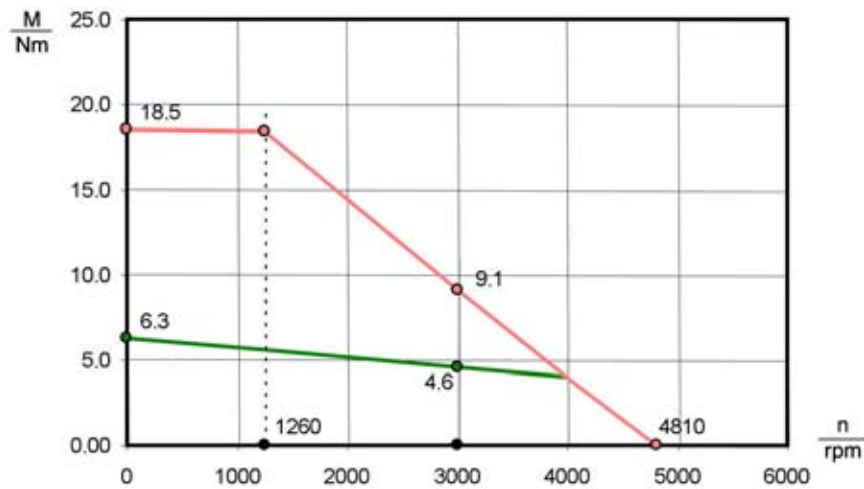

LSH-097-3-30-320

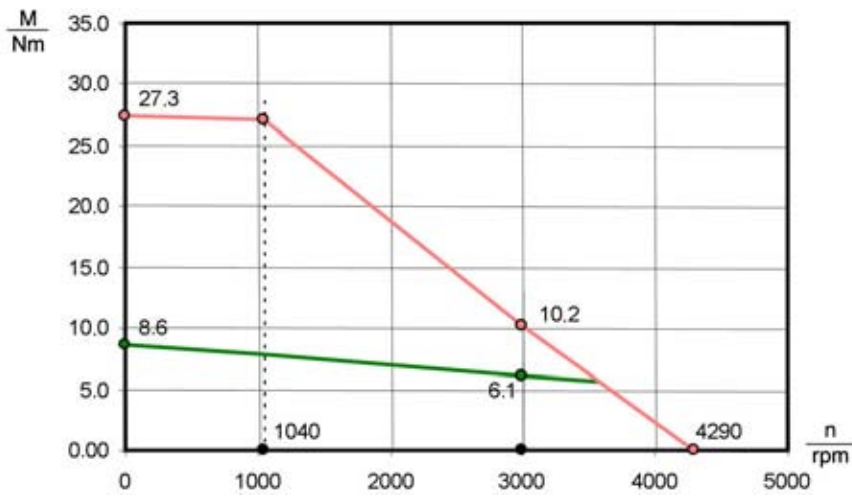

Motor type LSH-097 ($U_{ZK} = 560 \text{ V}$)



Motor length [mm]	K (with resolver)	K (with optical encoder G3, G5, G12.x)	K (with optical encoder G6.x)	Additional length for version LSX-xxx-...,B (brake)
LSH-097-1-30-560	129	166	150	41
LSH-097-2-30-560	159	196	180	41
LSH-097-3-30-560	189	226	210	41

Dimensional drawing

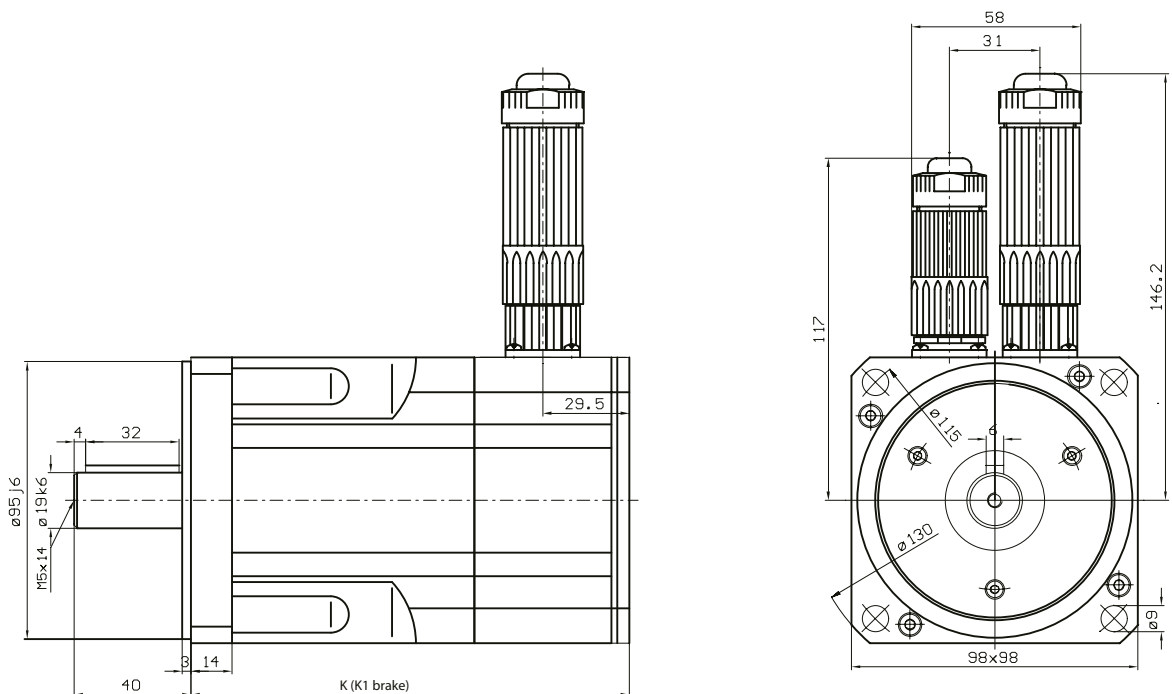

Technical data	Symbols	LSH-097-1-30-560	LSH-097-2-30-560	LSH-074-3-30-560
Nominal speed	n_n	3000 rpm	3000 rpm	3000 rpm
Nominal frequency	f_N	250 Hz	250 Hz	250 Hz
DC link voltage (controller)	U_{dc}	560 V	560 V	560 V
Rated voltage	U_n	330 V	330 V	330 V
Nominal torque	M_n	3.2 Nm	4.6 Nm	6.1 Nm
Rated current	I_n	2.8 A	3.6 A	4.8 A
Power	P	1.0 kW	1.44 kW	1.9 kW
Standstill torque	M_0	4.1 Nm	6.3 Nm	8.6 Nm
Standstill current	I_0	3.4 A	4.8 A	6.4 A
Maximum permissible torque	M_{max}	11.1 Nm	18.5 Nm	27.0 Nm
Maximum permissible current	I_{max}	13.6 A	21.0 A	31.0 A
Maximum permissible speed	n_{max}	6000 rpm	6000 rpm	6000 rpm
Voltage constant	K_E	72.0 V/1000	80.0 V/1000	81.0 V/1000
Torque constant	K_T	1.19 Nm/A	1.32 Nm/A	1.34 Nm/A
Winding resistance (two phases)	R_{2ph}	4.0 Ω	2.7 Ω	1.81 Ω
Winding inductance (two phases)	L_{2ph}	34.0 mH	25.5 mH	18.6 mH
No-load speed	n_0	4570 rpm	4120 rpm	4070 rpm
Electrical time constant	T_{el}	8.5 ms	9.5 ms	10.3 ms
Thermal time constant	T_{th}	29 min.	31 min.	33 min.
Moment of inertia of the rotor	J	0.00017 kgm ²	0.00026 kgm ²	0.00035 kgm ²
Mass	m	4.28 kg	5.34 kg	6.96 kg
Brake (optional)				
Rated voltage $\pm 10\%$	U_N		24 V $\pm 10\%$	
Rated current at 20 °C for release	I_N		0.75 A	
Permissible maximum speed	n_{max}		10,000 rpm	
Permissible frictional work	W_R		0.89 x 10 ⁶ Ws	
Moment of inertia	J_B		0.000054 kgm ²	
Mass	m		0.46 kg	
Braking torque	M_H		9.0 Nm	

Motor type LSH-097 ($U_{ZK} = 560 \text{ V}$)

Explanation of characteristic lines:

The upper characteristic line (M_{max}) describes the short-time maximum possible torque at the corresponding rotation speed (important for dynamic processes).

The lower characteristic line (M_{nenn}) shows the thermally permissible continuous torque.

2

LSH-097-1-30-560

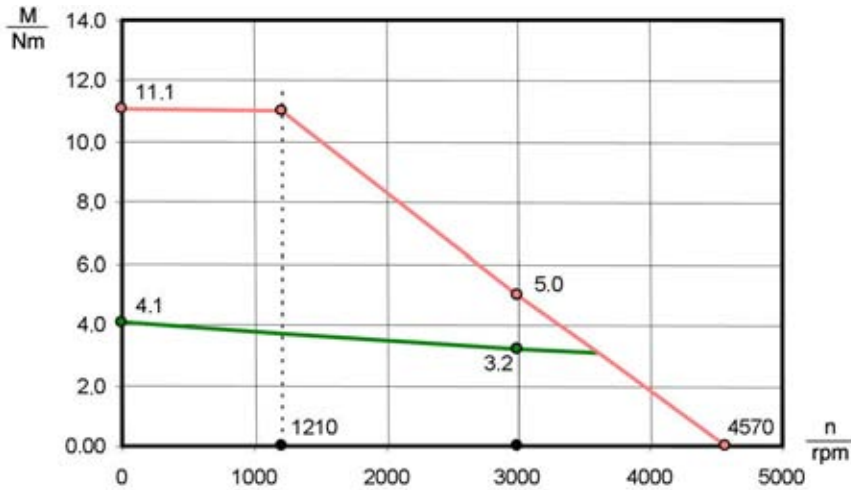

LSH-097-2-30-560

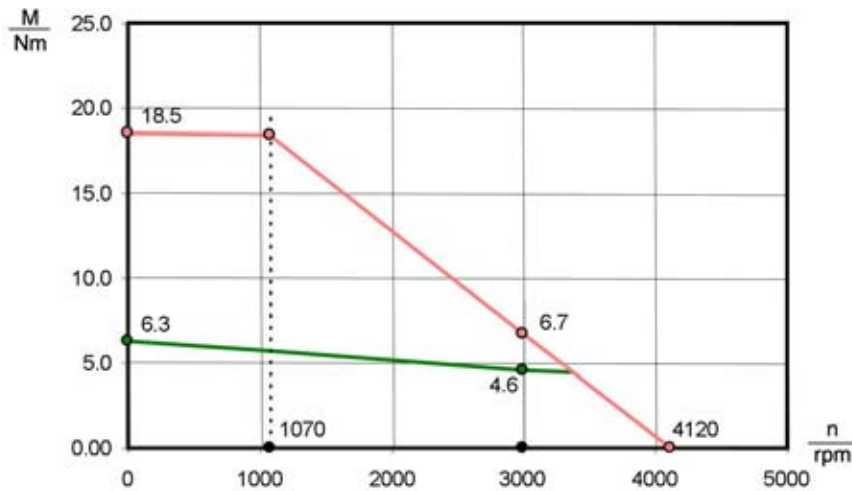

LSH-097-3-30-560

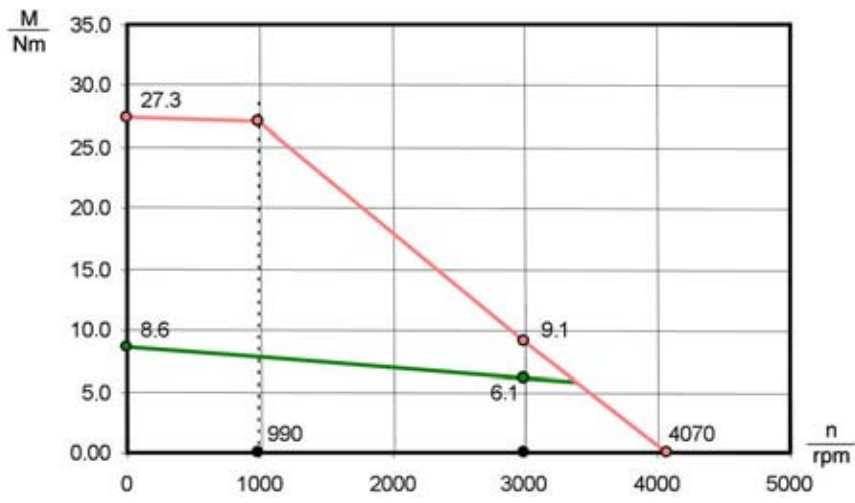

Motor type LSH-127 ($U_{ZK} = 560 \text{ V}$)



Motor length [mm]	K (with resolver)	K (with optical encoder G3, G5, G12.x)	K (with optical encoder G6.x)	Additional length for version LSX-xxx-...,B (brake)
LSH-127-1-30-560	172	192	175	52
LSH-127-2-30-560	200	220	203	52
LSH-127-3-30-560	230	250	233	52
LSH-127-4-30-560	290	310	293	52

Dimensional drawing

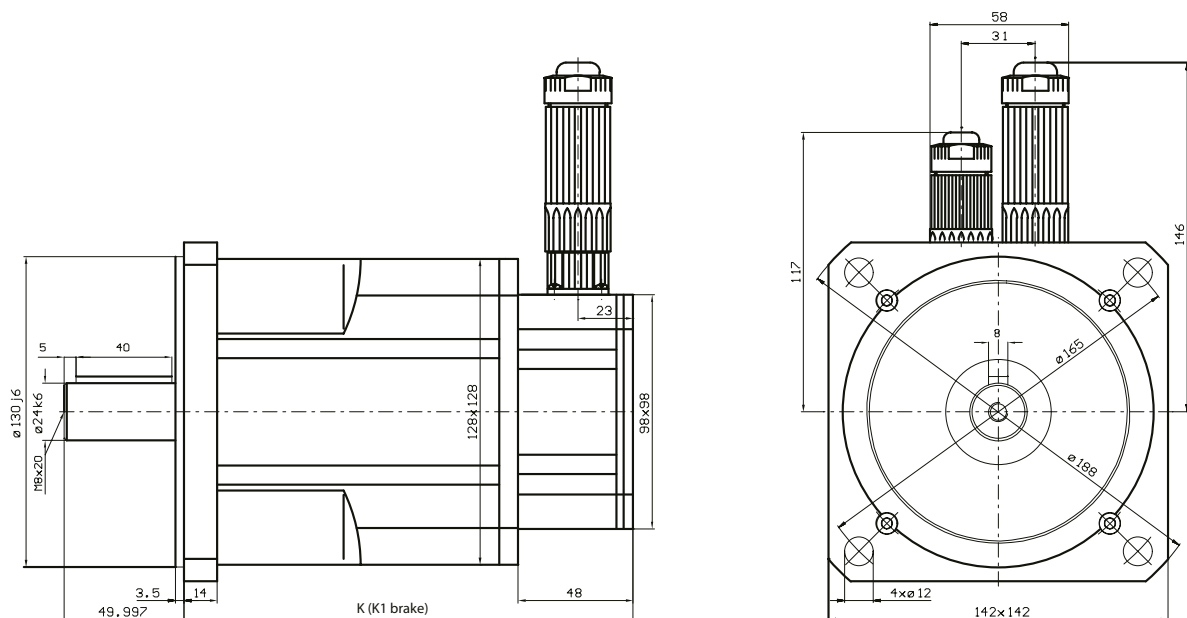

Technical data	Symbols	LSH-127-1-30-560	LSH-127-2-30-560	LSH-127-3-30-560	LSH-127-4-30-560
Nominal speed	n_n	3000 rpm	3000 rpm	3000 rpm	3000 rpm
Nominal frequency	f_N	250 Hz	250 Hz	250 Hz	250 Hz
DC link voltage (controller)	U_{dc}	560 V	560 V	560 V	560 V
Rated voltage	U_n	330 V	330 V	330 V	330 V
Nominal torque	M_n	8.4 Nm	10.9 Nm	14.3 Nm	21.0 Nm
Rated current	I_n	7.9 A	9.6 A	13.1 A	14.9 A
Power	P	2.63 kW	3.42 kW	4.11 kW	6.60 kW
Standstill torque	M_0	11.6 Nm	14.9 Nm	18.7 Nm	27.3 Nm
Standstill current	I_0	10.3 A	12.5 A	16.4 A	19.0 A
Maximum permissible torque	M_{max}	32 Nm	41.0 Nm	51.0 Nm	75.0 Nm
Maximum permissible current	I_{max}	49.0 A	49.0 A	61.0 A	68.0 A
Maximum permissible speed	n_{max}	9000 rpm	9000 rpm	9000 rpm	9000 rpm
Voltage constant	K_E	68.0 V/1000	72.0 V/1000	74.0 V/1000	87.0 V/1000
Torque constant	K_T	1.12 Nm/A	1.19 Nm/A	1.14 Nm/A	1.44 Nm/A
Winding resistance (two phases)	R_{2ph}	0.71 Ω	0.48 Ω	0.35 Ω	0.32 Ω
Winding inductance (two phases)	L_{2ph}	11.4 mH	8.5 mH	6.4 mH	6.8 mH
No-load speed	n_0	4840 rpm	4580 rpm	4780 rpm	3790 rpm
Electrical time constant	T_{el}	16.1 ms	17.7 ms	18.3ms	21 ms
Thermal time constant	T_{th}	50 min.	55 min.	60 min.	75 min.
Moment of inertia of the rotor	J	0.00068 kgm ²	0.00083 kgm ²	0.00110 kgm ²	0.00153 kgm ²
Mass	m	8.1 kg	10.1 kg	12.1 kg	16.1 kg
Brake (optional)					
Rated voltage $\pm 10\%$	U_N	24 V $\pm 10\%$			
Rated current at 20 °C for release	I_N	1.0 A			
Permissible maximum speed	n_{max}	10,000 rpm			
Permissible frictional work	W_R	1.29 x 10 ⁶ Ws			
Moment of inertia	J_B	0.000166 kgm ²			
Mass	m	0.9 kg			
Braking torque	M_H	18 Nm			

Motor type LSH-127 ($U_{ZK} = 560 \text{ V}$)

Explanation of characteristic lines:

The upper characteristic line (M_{max}) describes the short-time maximum possible torque at the corresponding rotation speed (important for dynamic processes).

The lower characteristic line (M_{nenn}) shows the thermally permissible continuous torque.

2

LSH-127-1-30-560

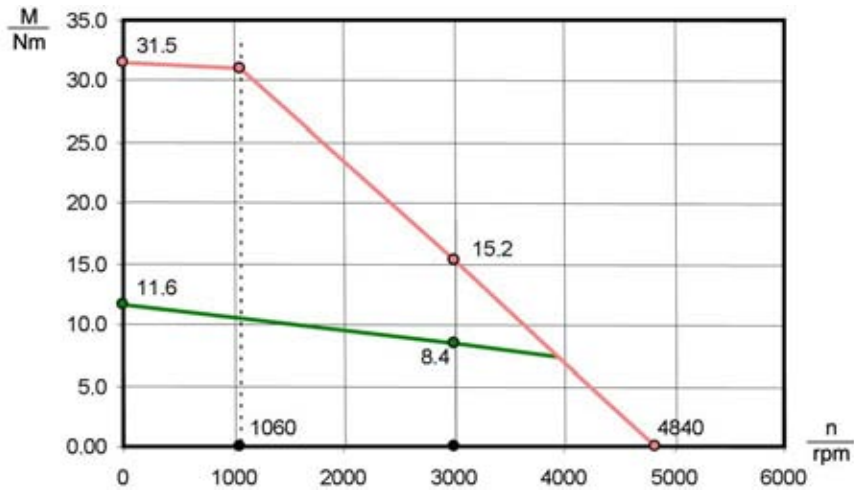

LSH-127-2-30-560

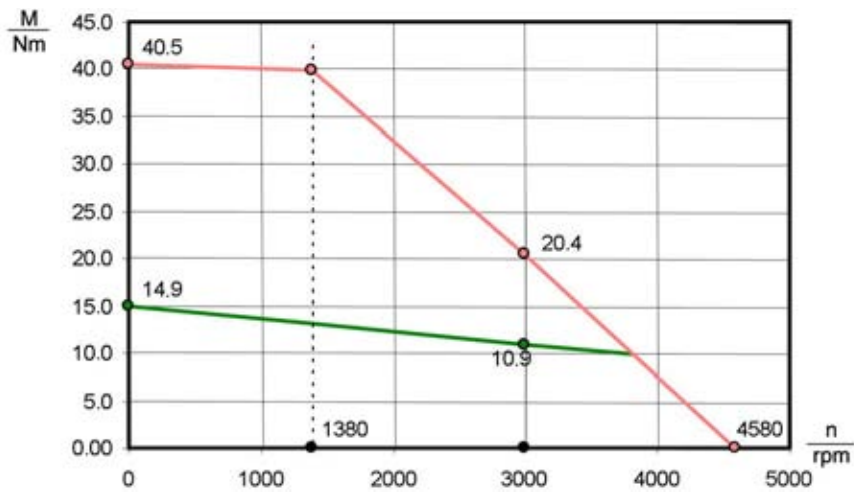

LSH-127-3-30-560

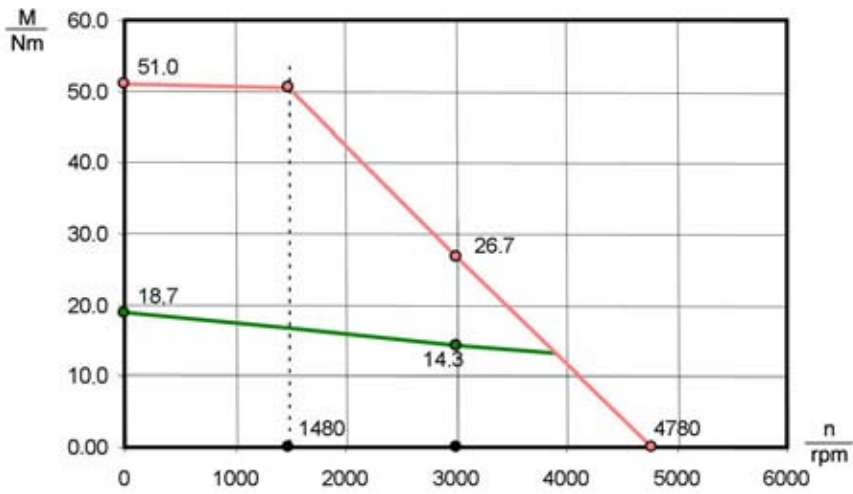

LSH-127-4-30-560

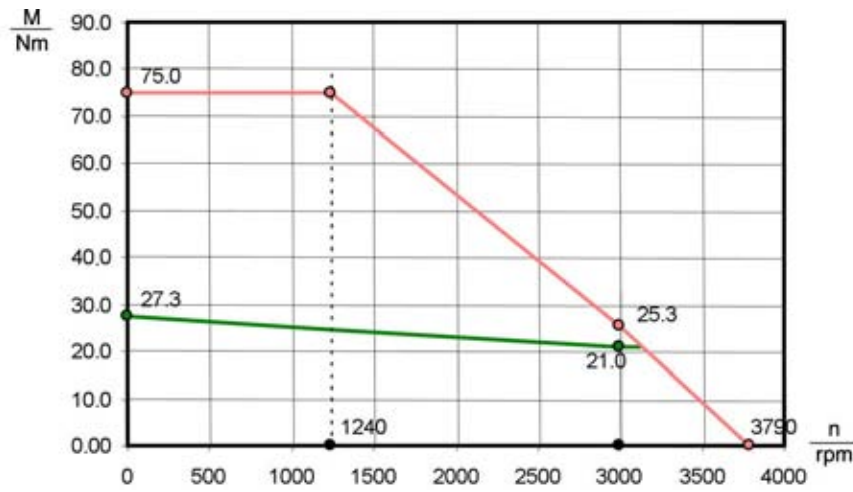

Area for your notes:

2

LST servomotors overview

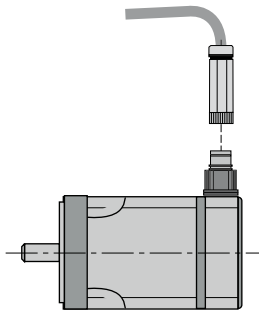

Type	U _{DC}	Page
LST-037	320 V	3 - 4
LST-050	320 V	3 - 8
LST-074	320 V	3 - 12
	560 V	3 - 16
LST-097	320 V	3 - 20
	560 V	3 - 24
LST-127	560 V	3 - 28
LST-158	560 V	3 - 32
LST-190	560 V	3 - 36
LST220	560 V	3 - 40

LST motor – the versatile one

Featuring conventional winding technology, the LST motor combines all the advantages of a 6-pole synchronous servomotor.

- Well suited to speeds up to 9000 rpm. Special windings are available on request.
- High overload capacity even at standstill based on efficient heat distribution in the stator packet.
- Increased rotor moment of inertia for torque adaptation.

Technical data, motor	Standstill torque M_0 [Nm]	Nominal torque M_N [Nm]	Rated current at 560 V I_N [A]	Rated current at 320 V I_N [A]	Nominal speed n_N [rpm]
LST-037-1	0.10	0.09	-	0.56	6000
LST-037-2	0.20	0.18	-	0.92	6000
LST-037-3	0.30	0.27	-	0.89	6000
LST-050-1	0.20	0.19	-	0.60	4500
LST-050-2	0.40	0.36	-	0.88	4500
LST-050-3	0.60	0.55	-	1.18	4500
LST-050-4	0.80	0.72	-	1.47	4500
LST-050-5	0.95	0.85	-	1.71	4500
LST-074-1	0.65	0.60	0.64	1.04	3000
LST-074-2	1.30	1.15	0.95	1.58	3000
LST-074-3	1.90	1.60	1.26	2.20	3000
LST-074-4	2.50	2.20	1.62	2.70	3000
LST-074-5	3.00	2.50	1.82	3.00	3000
LST-097-1	2.60	2.30	1.85	3.00	3000
LST-097-2	3.90	3.30	2.60	4.30	3000
LST-097-3	5.30	4.60	3.80	5.90	3000
LST-097-4	7.50	6.40	4.40	8.10	3000
LST-097-5	9.50	8.50	6.20	10.5	3000
LST-127-1	6.60	5.70	4.00	-	3000
LST-127-2	10.5	8.80	6.30	-	3000
LST-127-3	13.5	11.0	9.50	-	3000
LST-127-4	17.0	14.5	10.0	-	3000
LST-127-5	22.0	17.0	13.0	-	3000
LST-158-1	13.5	13.0	8.20	-	3000
LST-158-2	19.0	17.0	10.6	-	3000
LST-158-3	22.0	19.0	12.3	-	3000
LST-158-4	29.0	24.0	14.7	-	3000
LST-158-5	35.0	26.0	18.2	-	3000
LST-190-1	27.0	21.0	13.5	-	3000
LST-190-2	32.0	23.0	15.0	-	3000
LST-190-3	40.0	26.0	17.9	-	3000
LST-220-1	40.0	30.0	17.8	-	3000
LST-220-2	68.0	50.0	31.1	-	3000
LST-220-3	93.0	60.0	43.6	-	3000
LST-220-4	115.0	50.0	29.3	-	3000

Area for your notes:

Motor type LST-037 ($U_{ZK} = 320 \text{ V}$)



Motor length [mm]	K (with resolver)	K (with optical encoder G12.x)	K (with optical encoder G6.x)	Additional length for version LSX-xxx-...,B (brake)
LST-037-1-60-320	81			30
LST-037-2-60-320	86		not available	30
LST-037-3-60-320	111			30

Dimensional drawing

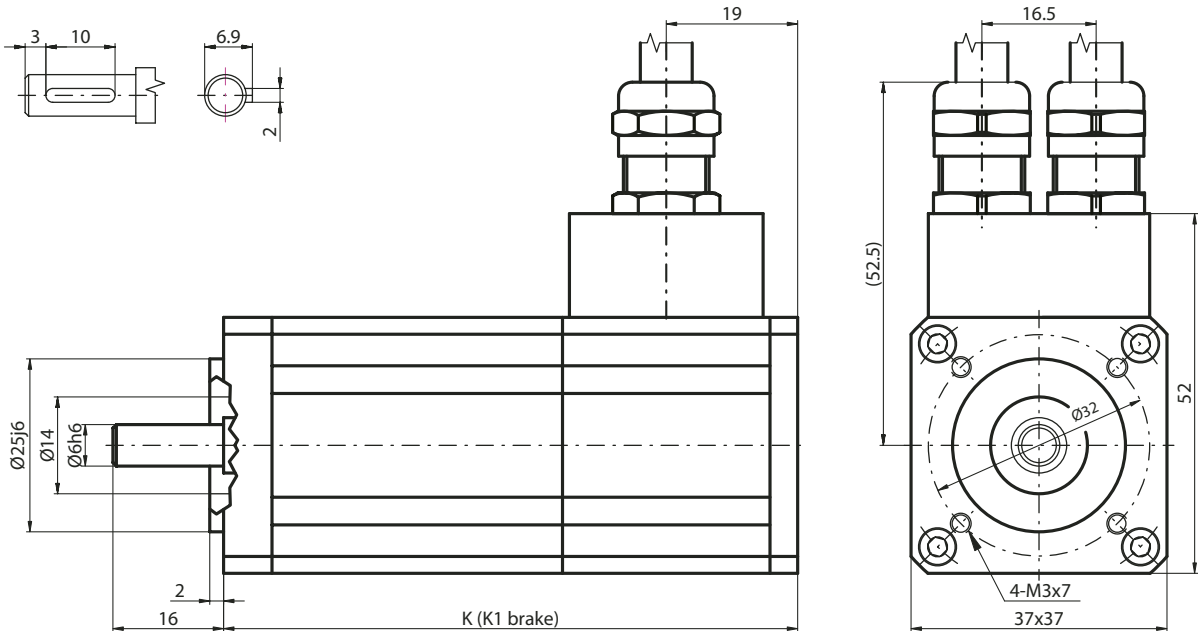

Technical data	Symbols	LST-037-1-60-320	LST-037-2-60-320	LST-037-3-60-320
Nominal speed	n_n	6000 rpm	6000 rpm	6000 rpm
Nominal frequency	f_N	300 Hz	300 Hz	300 Hz
DC link voltage (controller)	U_{dc}	320 V	320 V	320 V
Rated voltage	U_n	200 V	200 V	200 V
Nominal torque	M_n	0.09 Nm	0.18 Nm	0.27 Nm
Rated current	I_n	0.56 A	0.92 A	0.89 A
Power	P	0.056 kW	0.11 kW	0.17 kW
Standstill torque	M_0	0.10 Nm	0.20 Nm	0.30 Nm
Standstill current	I_0	0.58 A	0.97 A	0.95 A
Maximum permissible torque	M_{max}	0.40 Nm	0.80 Nm	1.20 Nm
Maximum permissible current	I_{max}	2.5 A	4.2 A	4.1 A
Maximum permissible speed	n_{max}	12000 rpm	12000 rpm	12000 rpm
Voltage constant	K_E	10.5 V/1000	12.5 V/1000	19.0 V/1000
Torque constant	K_T	0.17 Nm/A	0.21 Nm/A	0.31 Nm/A
Winding resistance (two phases)	R_{2ph}	38.9 Ω	18.9 Ω	22.9 Ω
Winding inductance (two phases)	L_{2ph}	6.5 mH	4.5 mH	6.5 mH
No-load speed	n_0	19050 rpm	16000 rpm	10460 rpm
Electrical time constant	T_{el}	0.17 ms	0.24 ms	0.28 ms
Thermal time constant	T_{th}	18 min.	20 min.	20 min.
Moment of inertia of the rotor	J	0.000006 kgm ²	0.000008 kgm ²	0.000008 kgm ²
Mass	m	0.37 kg	0.45 kg	0.45 kg
Brake (optional)				
Rated voltage	U_N	24 V \pm 10 %		
Rated current at 20 °C for release	I_N	0.33 A		
Permissible maximum speed	n_{max}	10,000 rpm		
Permissible frictional work	W_R	0.20 x 10 ⁶ Ws		
Moment of inertia	J_B	0.0000013 kgm ²		
Mass	m	0.075 kg		
Braking torque	M_H	0.4 Nm		

Motor type LST-037 ($U_{ZK} = 320 \text{ V}$)

Explanation of characteristic lines:

The upper characteristic line (M_{\max}) describes the short-time maximum possible torque at the corresponding rotation speed (important for dynamic processes).

The lower characteristic line (M_{nein}) shows the thermally permissible continuous torque.

LST-037-1-60-320

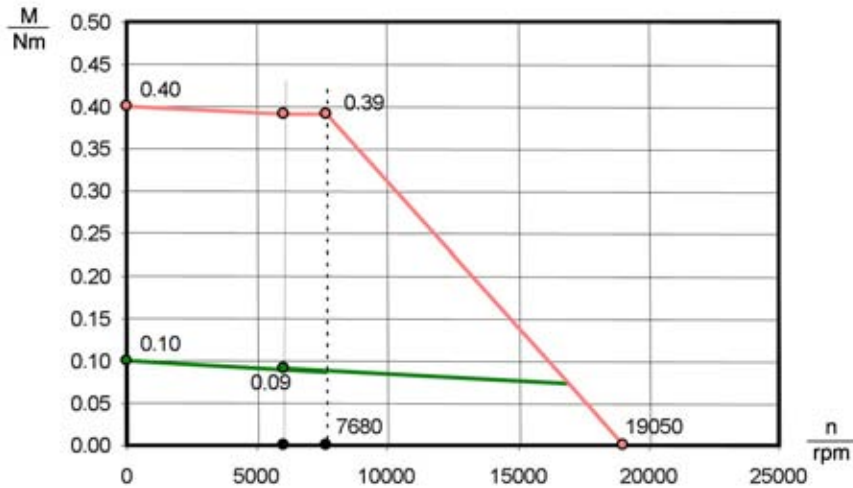

LST-037-2-60-320

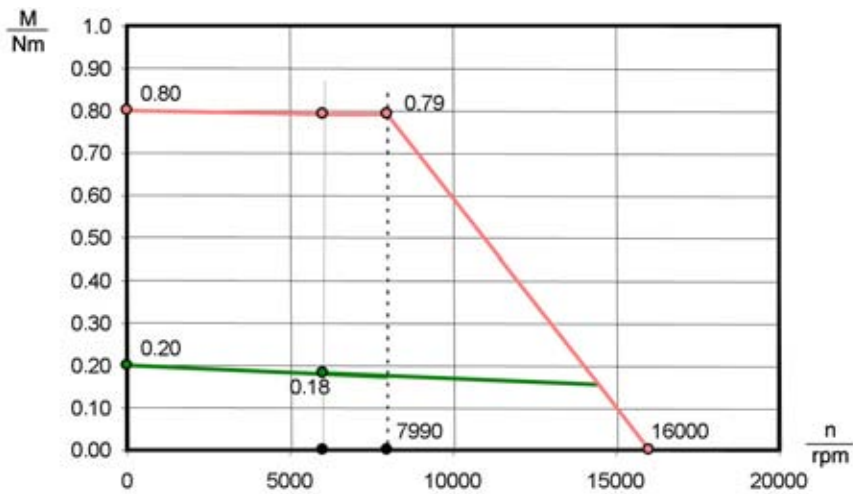

LST-037-3-60-320

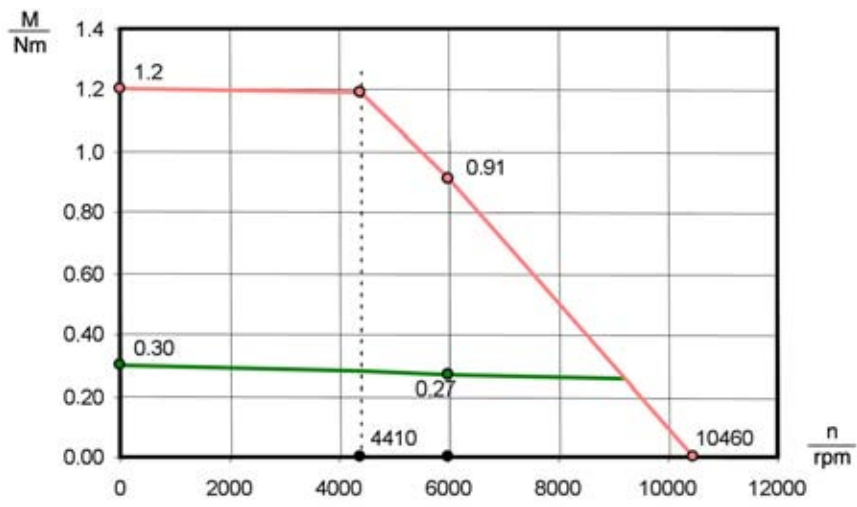

Motor type LST-050 ($U_{ZK} = 320 \text{ V}$)



Motor length [mm]	K (with resolver)	K (with optical encoder G12.2S/G12.2M5)	K (with optical encoder G6.2S/G6.2M)	Additional length for version LSX-xxx-...,B (brake)
LST-050-1-45-320	98		141.5	33
ST-050-2-45-320	113		156.5	33
LST-050-3-45-320	128	not available	171.5	33
LST-050-4-45-320	143		186.5	33
LST-050-5-45-320	158		201.5	33

Dimensional drawing

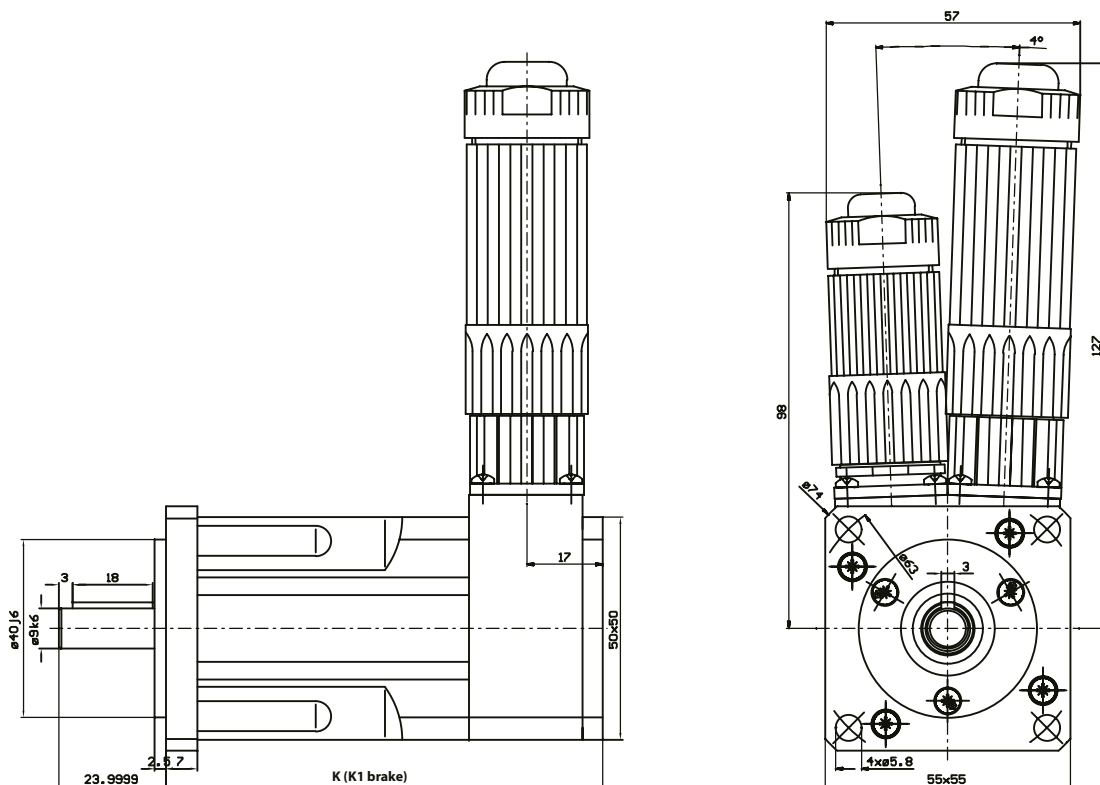

Technical data	Symbols	LST-050-1-45-320	LST-050-2-45-320	LST-050-3-45-320	LST-050-4-45-320	LST-050-5-45-320
Nominal speed	n_n	4500 rpm	4500 rpm	4500 rpm	4500 rpm	4500 rpm
Nominal frequency	f_n	225 Hz	225 Hz	225 Hz	225 Hz	225 Hz
DC link voltage (controller)	U_{dc}	320 V	320 V	320 V	320 V	320 V
Rated voltage	U_n	200 V	200 V	200 V	200 V	200 V
Nominal torque	M_n	0.19 Nm	0.36 Nm	0.55 Nm	0.72 Nm	0.85 Nm
Rated current	I_n	0.60 A	0.88 A	1.18 A	1.47 A	1.71 A
Power	P	0.089 kW	0.17 kW	0.26 kW	0.34 kW	0.44 kW
Standstill torque	M_0	0.20 Nm	0.40 Nm	0.60 Nm	0.80 Nm	0.95 Nm
Standstill current	I_0	0.59 A	0.93 A	1.23 A	1.56 A	1.82 A
Maximum permissible torque	M_{max}	0.80 Nm	1.6 Nm	2.4 Nm	3.2 Nm	3.8 Nm
Maximum permissible current	I_{max}	2.5 A	4.0 A	5.3 A	6.7 A	7.8 A
Maximum permissible speed	n_{max}	12000 rpm	12000 rpm	12000 rpm	12000 rpm	12000 rpm
Voltage constant	K_E	20.5 V/1000	26.0 V/1000	29.5 V/1000	31.0 V/1000	31.5 V/1000
Torque constant	K_T	0.34 Nm/A	0.43 Nm/A	0.49 Nm/A	0.51 Nm/A	0.52 Nm/A
Winding resistance (two phases)	R_{2ph}	54 Ω	26.3 Ω	19.9 Ω	14.6 Ω	10.7 Ω
Winding inductance (two phases)	L_{2ph}	32 mH	21.4 mH	17.2 mH	14.4 mH	11.3 mH
No-load speed	n_0	9760 rpm	7690 rpm	6780 rpm	6450 rpm	6350 rpm
Electrical time constant	T_{el}	0.59 ms	0.82 ms	0.87 ms	0.98 ms	1.1 ms
Thermal time constant	T_{th}	10 min.	15 min.	20 min.	22 min.	27 min.
Moment of inertia of the rotor	J	0.000006 kgm ²	0.000008 kgm ²	0.000011 kgm ²	0.000013 kgm ²	0.000018 kgm ²
Mass	m	0.90 kg	1.06 kg	1.21 kg	1.36 kg	1.52 kg
Brake (optional)						
Rated voltage	U_N	24 V \pm 10 %				
Rated current at 20 °C for release	I_N	0.46 A				
Permissible maximum speed	n_{max}	10,000 rpm				
Permissible frictional work	WR	0.41 x 10 ⁶ Ws				
Moment of inertia	J_B	0.000007 kgm ²				
Mass	m	0.15 kg				
Braking torque	M_H	2.0 Nm				

Motor type LST-050 ($U_{ZK} = 320 \text{ V}$)

Explanation of characteristic lines:

The upper characteristic line (M_{max}) describes the short-time maximum possible torque at the corresponding rotation speed (important for dynamic processes).

The lower characteristic line (M_{nenn}) shows the thermally permissible continuous torque.

3

LST-050-1-45-320

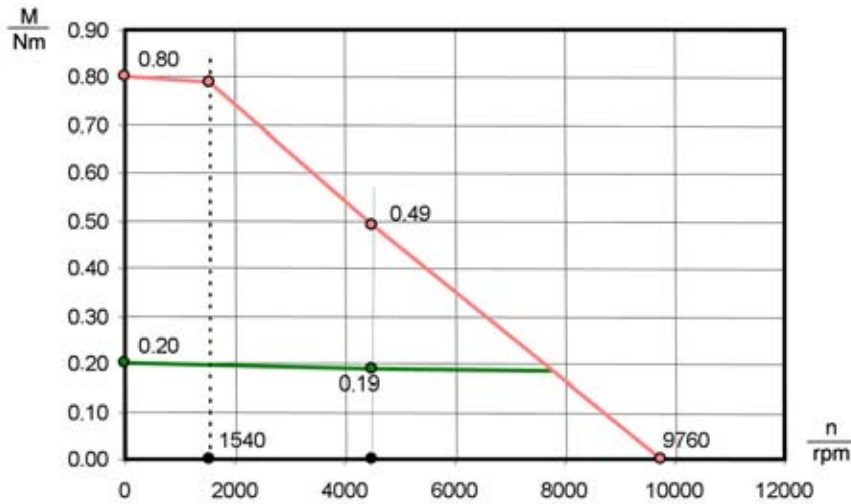

LST-050-2-45-320

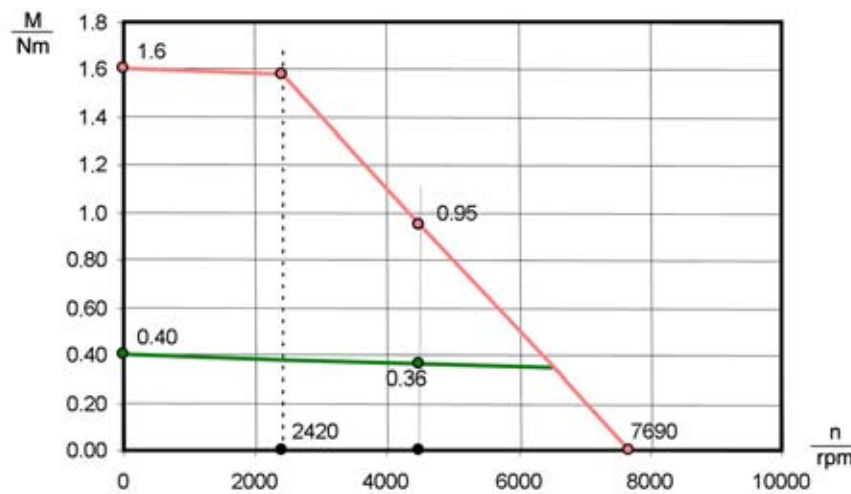

LST-050-3-45-320

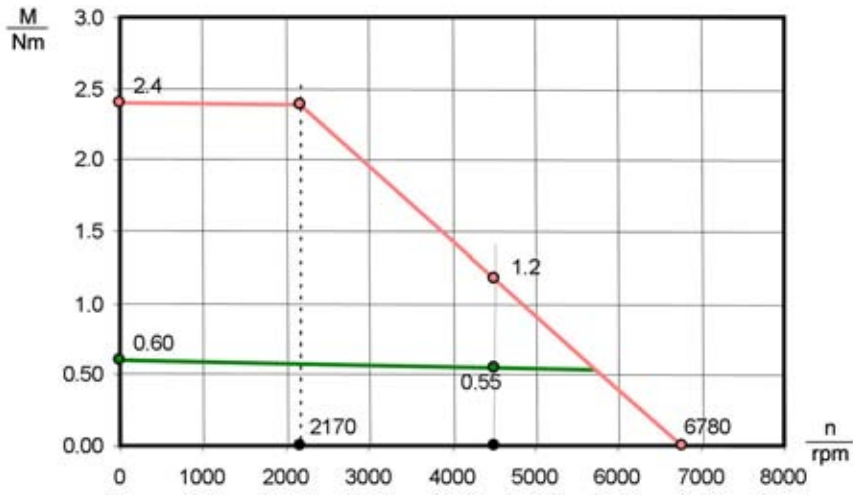

LST-050-4-45-320

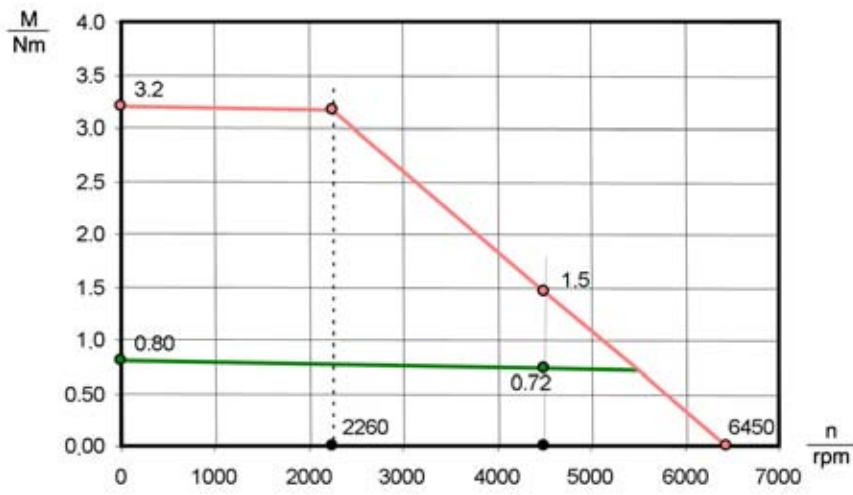

LST-050-5-45-320

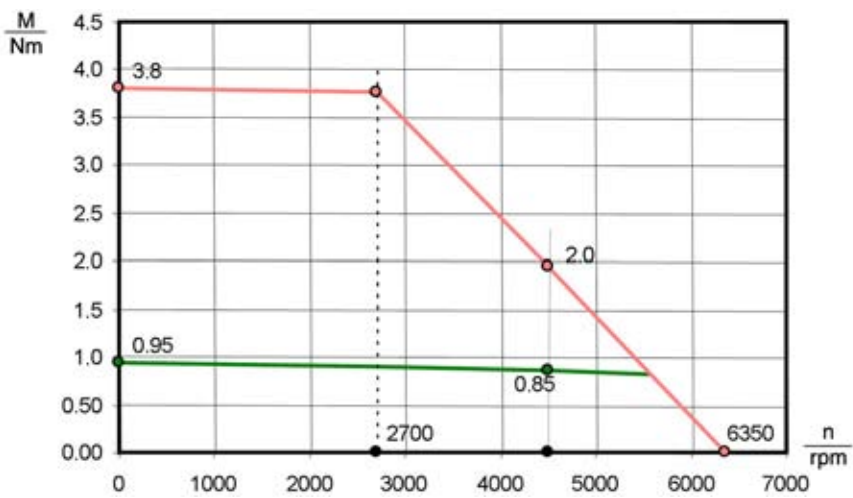

Motor type LST-074 ($U_{ZK} = 320\text{ V}$)



3

Motor length [mm]	K (with resolver)	K (with optical encoder G3, G5, G12.x)	K (with optical encoder G6.x)	Additional length for version LSX-xxx-...,B (brake)
LST-074-1-30-320	109	150	128.5	33
LST-074-2-30-320	127	168	146.5	33
LST-074-3-30-320	145	186	164.5	33
LST-074-4-30-320	163	204	182.5	33
LST-074-5-30-320	181	222	200.5	33

Dimensional drawing

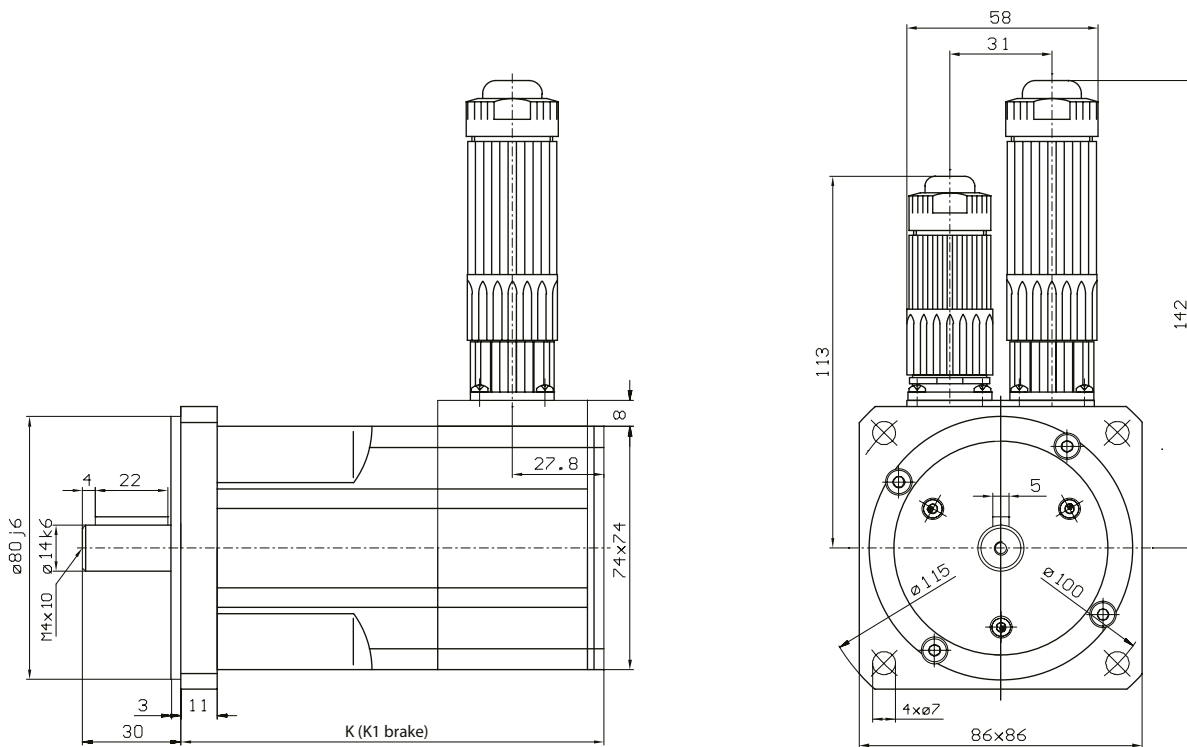

Technical data	Symbols	LST-074-1-30-320	LST-074-2-30-320	LST-074-3-30-320	LST-074-4-30-320	LST-074-5-30-320
Nominal speed	n_n	3000 rpm	3000 rpm	3000 rpm	3000 rpm	3000 rpm
Nominal frequency	f_n	150 Hz	150 Hz	150 Hz	150 Hz	150 Hz
DC link voltage (controller)	U_{dc}	320 V	320 V	320 V	320 V	320 V
Rated voltage	U_n	200 V	200 V	200 V	200 V	200 V
Nominal torque	M_n	0.60 Nm	1.15 Nm	1.6 Nm	2.2 Nm	2.5 Nm
Rated current	I_n	1.04 A	1.58 A	2.2 A	2.7 A	3.0 A
Power	P	0.18 kW	0.36 kW	0.5 kW	0.69 kW	0.78 kW
Standstill torque	M_0	0.65 Nm	1.3 Nm	1.9 Nm	2.5 Nm	3.0 Nm
Standstill current	I_0	1.06 A	1.67 A	2.5 A	3.0 A	3.5 A
Maximum permissible torque	M_{max}	2.6 Nm	5.2 Nm	7.6 Nm	10.0 Nm	12.0 Nm
Maximum permissible current	I_{max}	4.6 A	7.2 A	10.7 A	13.0 A	15.0 A
Maximum permissible speed	n_{max}	12000 rpm	12000 rpm	12000 rpm	12000 rpm	12000 rpm
Voltage constant	K_E	37.0 V/1000	47.0 V/1000	46.0 V/1000	50.0 V/1000	52.0 V/1000
Torque constant	K_T	0.61 Nm/A	0.78 Nm/A	0.76 Nm/A	0.83 Nm/A	0.86 Nm/A
Winding resistance (two phases)	R_{2ph}	28.2 Ω	12.7 Ω	6.7 Ω	5.4 Ω	4.1 Ω
Winding inductance (two phases)	L_{2ph}	33.3 mH	21.5 mH	13.1 mH	11.7 mH	9.4 mH
No-load speed	n_0	5410 rpm	4260 rpm	4350 rpm	4000 rpm	3850 rpm
Electrical time constant	T_{el}	1.2 ms	1.7 ms	2.0 ms	2.2 ms	2.3 ms
Thermal time constant	T_{th}	25 min.	30 min.	31 min.	32 min.	33 min.
Moment of inertia of the rotor	J	0.00005 kgm ²	0.000065 kgm ²	0.000092 kgm ²	0.00014 kgm ²	0.00015 kgm ²
Mass	m	1.75 kg	2.25 kg	2.7 kg	3.2 kg	3.65 kg
Brake (optional)						
Rated voltage	U_N	24 V \pm 10 %				
Rated current at 20 °C for release	I_N	0.5 A				
Permissible maximum speed	n_{max}	10,000 rpm				
Permissible frictional work	WR	0.58 x 10 ⁶ Ws				
Moment of inertia	J_B	0.000018 kgm ²				
Mass	m	0.3 kg				
Braking torque	M_H	4.5 Nm				

Motor type LST-074 ($U_{ZK} = 320\text{ V}$)

Explanation of characteristic lines:

The upper characteristic line (M_{max}) describes the short-time maximum possible torque at the corresponding rotation speed (important for dynamic processes).

The lower characteristic line (M_{nenn}) shows the thermally permissible continuous torque.

3

LST-074-1-30-320

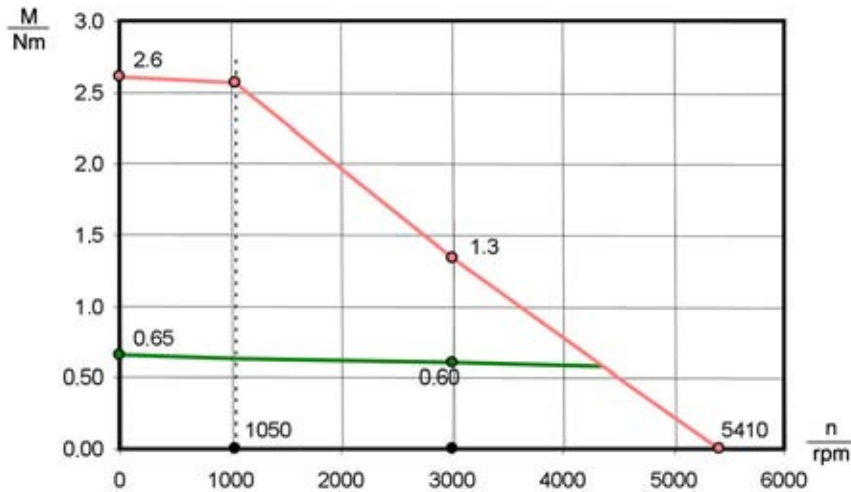

LST-074-2-30-320

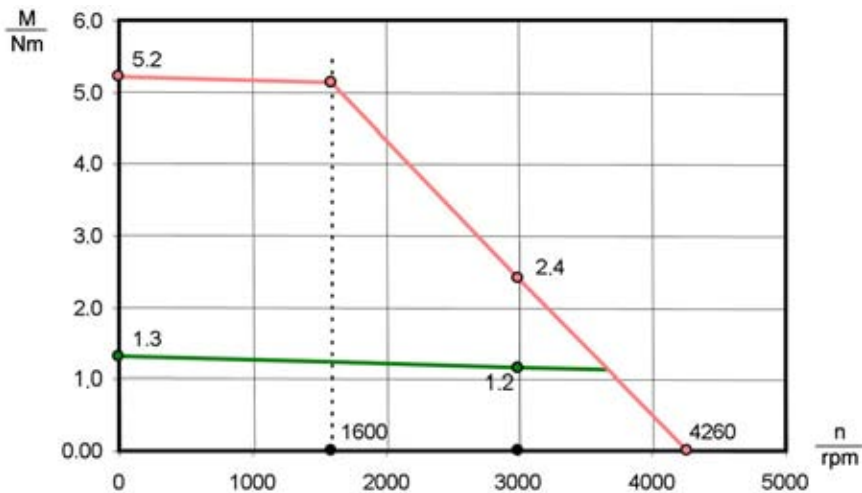

LST-074-3-30-320

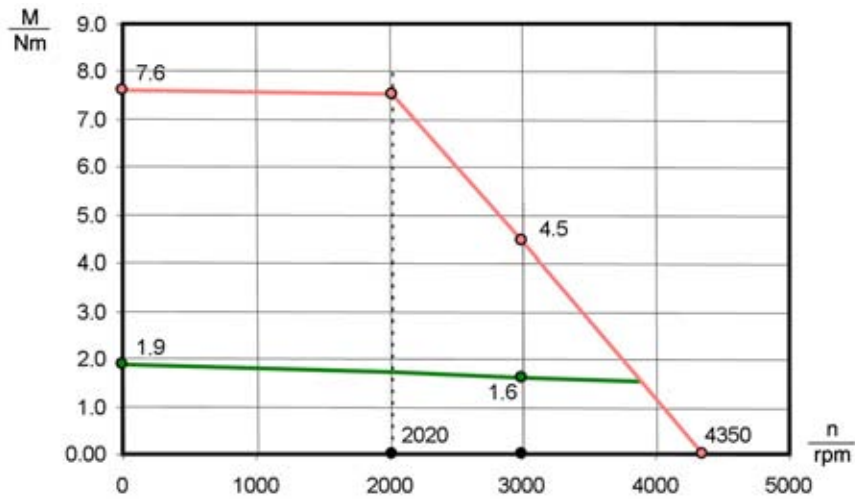

LST-074-4-30-320

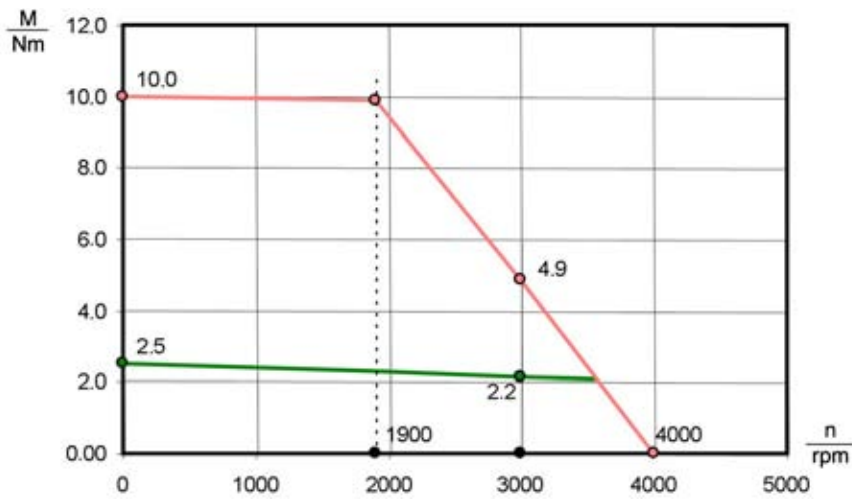

LST-074-5-30-320

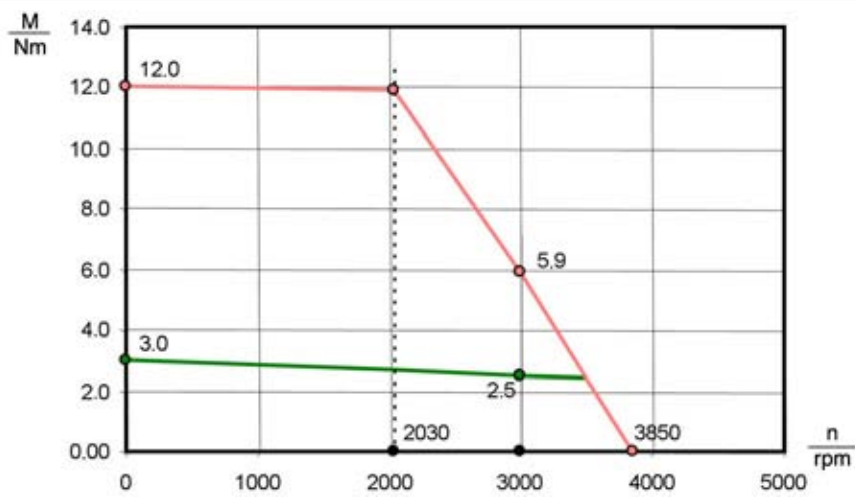

Motor type LST-074 ($U_{ZK} = 560 \text{ V}$)



Motor length [mm]	K (with resolver)	K (with optical encoder G3, G5, G12.x)	K (with optical encoder G6.x)	Additional length for version LSX-xxx-...,B (brake)
LST-074-1-30-560	109	150	128.5	33
LST-074-2-30-560	127	168	146.5	33
LST-074-3-30-560	145	186	164.5	33
LST-074-4-30-560	163	204	182.5	33
LST-074-5-30-560	181	222	200.5	33

Dimensional drawing

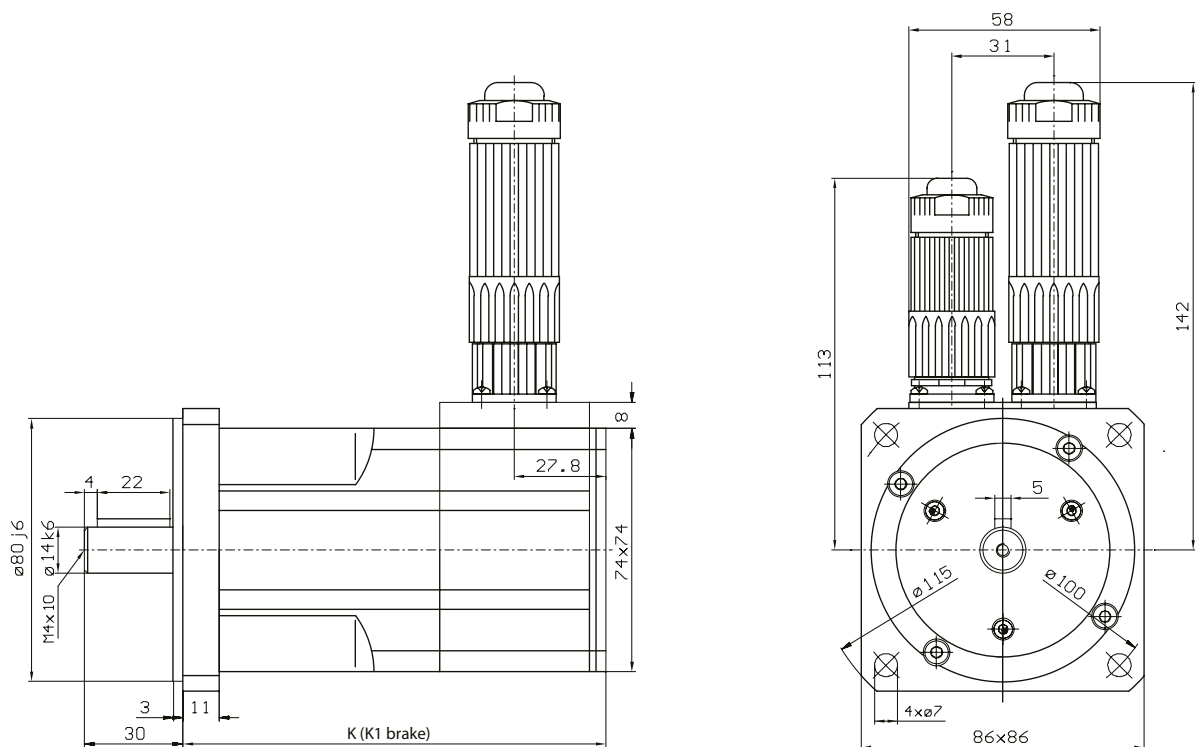

Technical data	Symbols	LST-074-1-30-560	LST-074-2-30-560	LST-074-3-30-560	LST-074-4-30-560	LST-074-5-30-560
Nominal speed	n_n	3000 rpm	3000 rpm	3000 rpm	3000 rpm	3000 rpm
Nominal frequency	f_n	150 Hz	150 Hz	150 Hz	150 Hz	150 Hz
DC link voltage (controller)	U_{dc}	560 V	560 V	560 V	560 V	560 V
Rated voltage	U_n	200 V	200 V	200 V	200 V	200 V
Nominal torque	M_n	0.60 Nm	1.15 Nm	1.6 Nm	2.2 Nm	2.5 Nm
Rated current	I_n	0.64 A	0.95 A	1.26 A	1.62 A	1.82 A
Power	P	0.18 kW	0.36 kW	0.5 kW	0.69 kW	0.78 kW
Standstill torque	M_0	0.65 Nm	1.3 Nm	1.9 Nm	2.5 Nm	3.0 Nm
Standstill current	I_0	0.65 A	1.01 A	1.42 A	1.8 A	2.1 A
Maximum permissible torque	M_{max}	2.6 Nm	5.2 Nm	7.6 Nm	10.0 Nm	12.0 Nm
Maximum permissible current	I_{max}	2.8 A	4.3 A	6.1 A	7.7 A	9.0 A
Maximum permissible speed	n_{max}	12000 rpm	12000 rpm	12000 rpm	12000 rpm	12000 rpm
Voltage constant	K_E	60.0 V/1000	46.0 V/1000	81.0 V/1000	84.0 V/1000	87.0 V/1000
Torque constant	K_T	0.99 Nm/A	0.78 Nm/A	1.34 Nm/A	1.39 Nm/A	1.44 Nm/A
Winding resistance (two phases)	R_{2ph}	75 Ω	34.5 Ω	20.9 Ω	15.0 Ω	11.6 Ω
Winding inductance (two phases)	L_{2ph}	88 mH	62 mH	40.4 mH	33.2 mH	26.7 mH
No-load speed	n_0	5500 rpm	4230 rpm	4070 rpm	3930 rpm	3790 rpm
Electrical time constant	T_{el}	1.2 ms	1.8 ms	1.9 ms	2.2 ms	2.3 ms
Thermal time constant	T_{th}	25 min.	30 min.	31 min.	32 min.	33 min.
Moment of inertia of the rotor	J	0.00005 kgm ²	0.000065 kgm ²	0.000092 kgm ²	0.00014 kgm ²	0.00015 kgm ²
Mass	m	1.75 kg	2.25 kg	2.7 kg	3.2 kg	3.65 kg
Brake (optional)						
Rated voltage	U_N	24 V \pm 10 %				
Rated current at 20 °C for release	I_N	0.5 A				
Permissible maximum speed	n_{max}	10,000 rpm				
Permissible frictional work	WR	0.58 x 10 ⁶ Ws				
Moment of inertia	J_B	0.000018 kgm ²				
Mass	m	0.3 kg				
Braking torque	M_H	4.5 Nm				

Motor type LST-074 ($U_{ZK} = 560 \text{ V}$)

Explanation of characteristic lines:

The upper characteristic line (M_{max}) describes the short-time maximum possible torque at the corresponding rotation speed (important for dynamic processes).

The lower characteristic line (M_{nenn}) shows the thermally permissible continuous torque.

3

LST-074-1-30-560

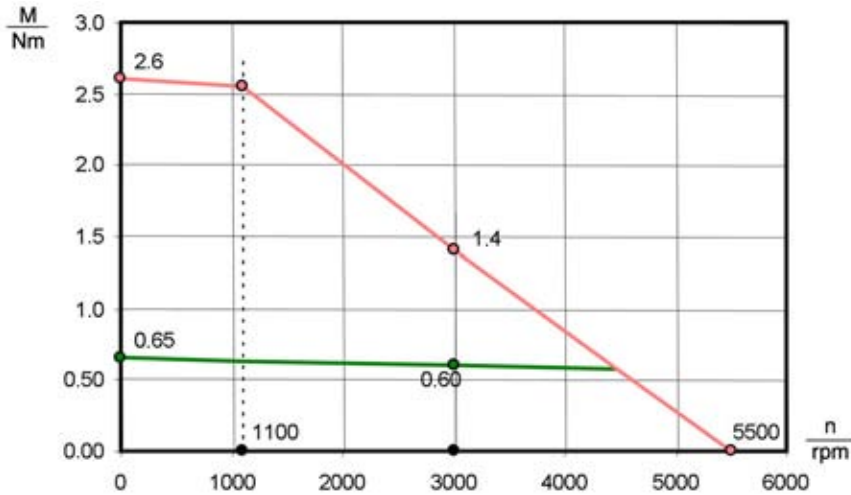

LST-074-2-30-560

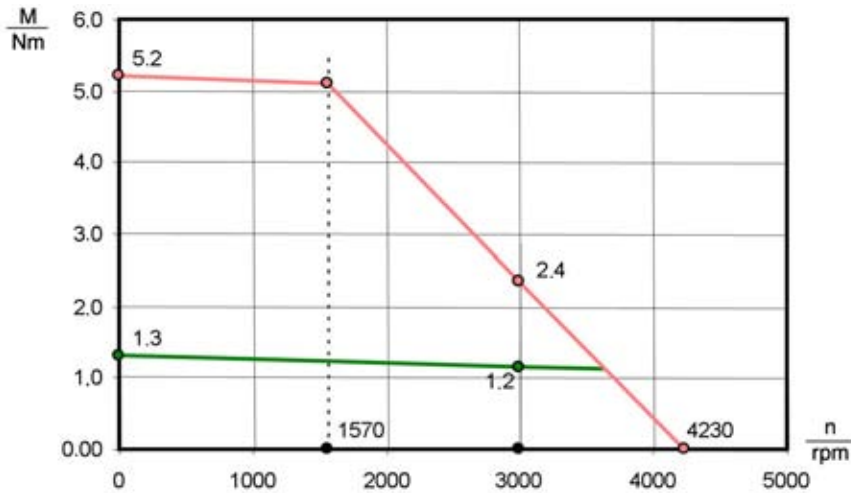

LST-074-3-30-560

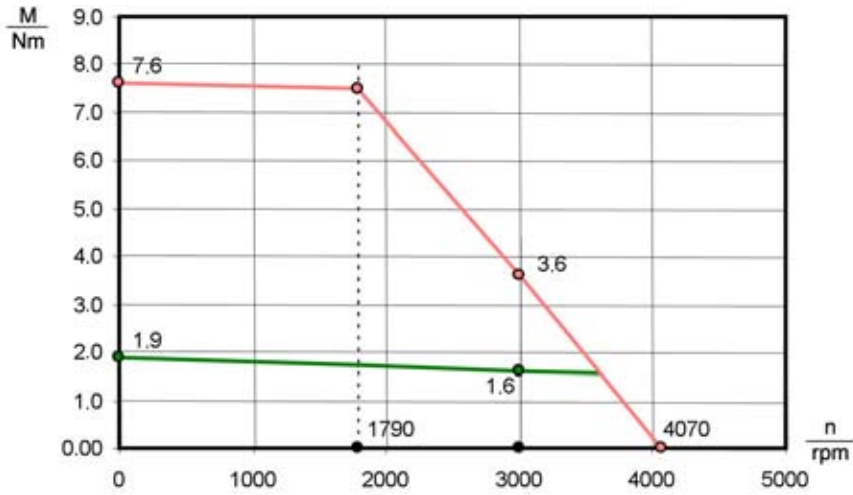

LST-074-4-30-560

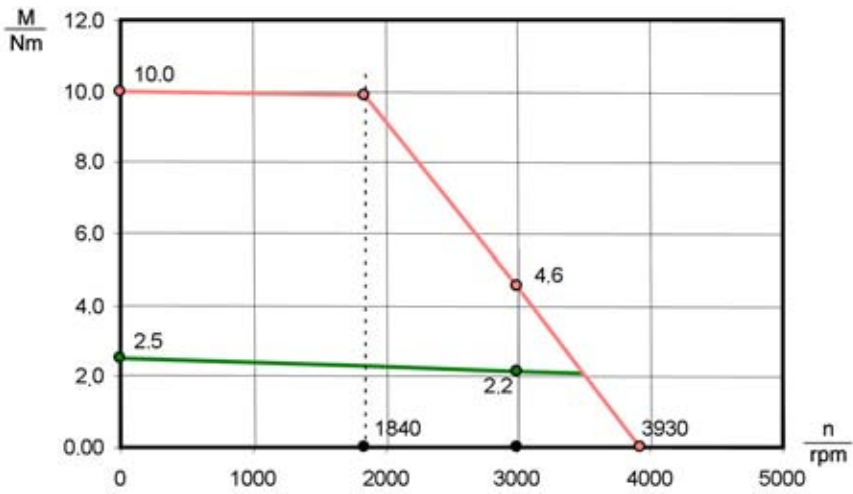

LST-074-5-30-560

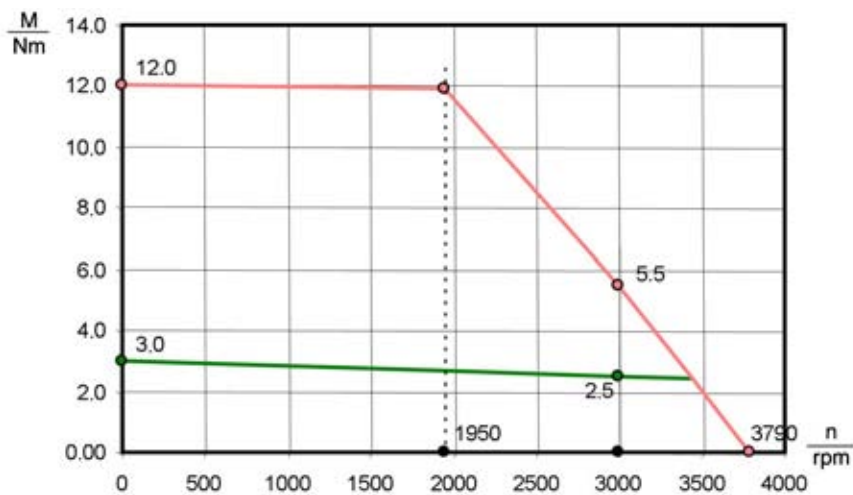

Motor type LST-097 ($U_{ZK} = 320\text{ V}$)



Motor length [mm]	K (with resolver)	K (with optical encoder G3, G5, G12.x)	K (with optical encoder G6.x)	Additional length for version LSX-xxx-...,B (brake)
LST-097-1-30-320	146	183	167	32
LST-097-2-30-320	161	198	18	32
LST-097-3-30-320	176	213	193	32
LST-097-4-30-320	221	228	219	32
LST-097-5-30-320	236	243	234	32

Dimensional drawing

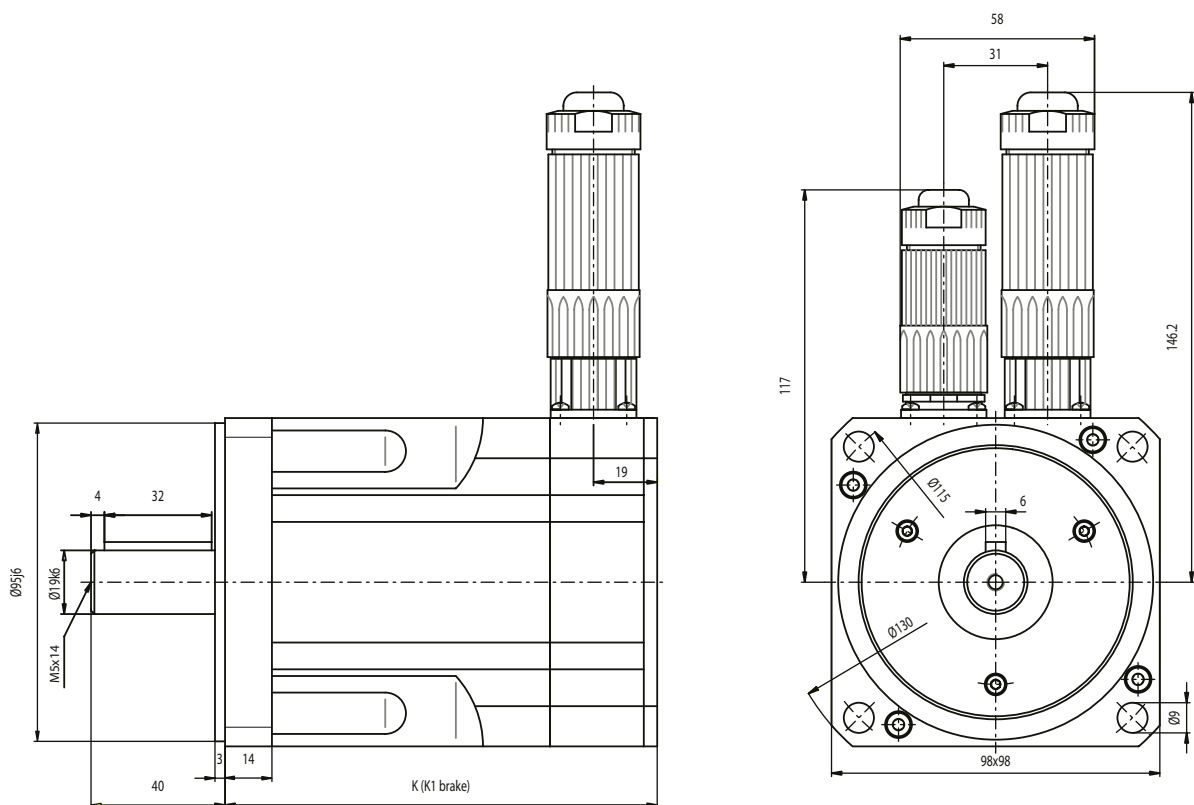

Technical data	Symbols	LST-097-1-30-320	LST-097-2-30-320	LST-097-3-30-320	LST-097-4-30-320	LST-097-5-30-320
Nominal speed	n_n	3000 rpm	3000 rpm	3000 rpm	3000 rpm	3000 rpm
Nominal frequency	f_n	150 Hz	150 Hz	150 Hz	150 Hz	150 Hz
DC link voltage (controller)	U_{dc}	320 V	320 V	320 V	320 V	320 V
Rated voltage	U_n	200 V	200 V	200 V	200 V	200 V
Nominal torque	M_n	2.3 Nm	3.3 Nm	4.6 Nm	6.4 Nm	8.5 Nm
Rated current	I_n	3.0 A	4.3 A	5.9 A	8.1 A	10.5 A
Power	P	0.72 kW	1.0 kW	1.44 kW	2.0 kW	2.67 kW
Standstill torque	M_0	2.6 Nm	3.9 Nm	5.3 Nm	7.5 Nm	9.5 Nm
Standstill current	I_0	3.1 A	4.8 A	6.5 A	9.1 A	11.3 A
Maximum permissible torque	M_{max}	10.4 Nm	15.6 Nm	21 Nm	30 Nm	38 Nm
Maximum permissible current	I_{max}	18.9 A	29 A	39.0 A	54 A	68 A
Maximum permissible speed	n_{max}	12000 rpm	12000 rpm	12000 rpm	12000 rpm	12000 rpm
Voltage constant	K_E	50.0 V/1000	49.0 V/1000	49.5 V/1000	50.0 V/1000	51.0 V/1000
Torque constant	K_T	0.83 Nm/A	0.81 Nm/A	0.82 Nm/A	0.83 Nm/A	0.84 Nm/A
Winding resistance (two phases)	R_{2ph}	3.6 Ω	2.3 Ω	1.66 Ω	0.87 Ω	0.59 Ω
Winding inductance (two phases)	L_{2ph}	15.9 mH	11.8 mH	9.8 mH	5.6 mH	4.1 mH
No-load speed	n_0	4000 rpm	4080 rpm	4040 rpm	4000 rpm	3920 rpm
Electrical time constant	T_{el}	4.4 ms	5.2 ms	5.9 ms	6.4 ms	6.9 ms
Thermal time constant	T_{th}	60 min.	65 min.	64 min.	66 min.	68 min.
Moment of inertia of the rotor	J	0.00019 kgm ²	0.00023 kgm ²	0.00027 kgm ²	0.00042 kgm ²	0.00061 kgm ²
Mass	m	4.5 kg	5.05 kg	5.6 kg	7.7 kg	10.5 kg
Brake (optional)						
Rated voltage	U_N	24 V \pm 10 %				
Rated current at 20 °C for release	I_N	0.75 A				
Permissible maximum speed	n_{max}	10,000 rpm				
Permissible frictional work	WR	0.89 x 10 ⁶ Ws				
Moment of inertia	J_B	0.000054 kgm ²				
Mass	m	0.46 kg				
Braking torque	M_H	9.0 Nm				

Motor type LST-097 ($U_{ZK} = 320\text{ V}$)

Explanation of characteristic lines:

The upper characteristic line (M_{max}) describes the short-time maximum possible torque at the corresponding rotation speed (important for dynamic processes).

The lower characteristic line (M_{nenn}) shows the thermally permissible continuous torque.

3

LST-097-1-30-320

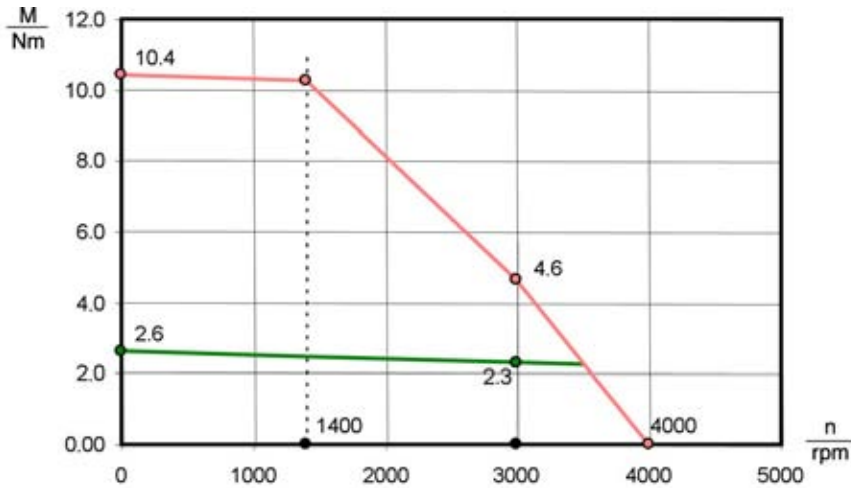

LST-097-2-30-320

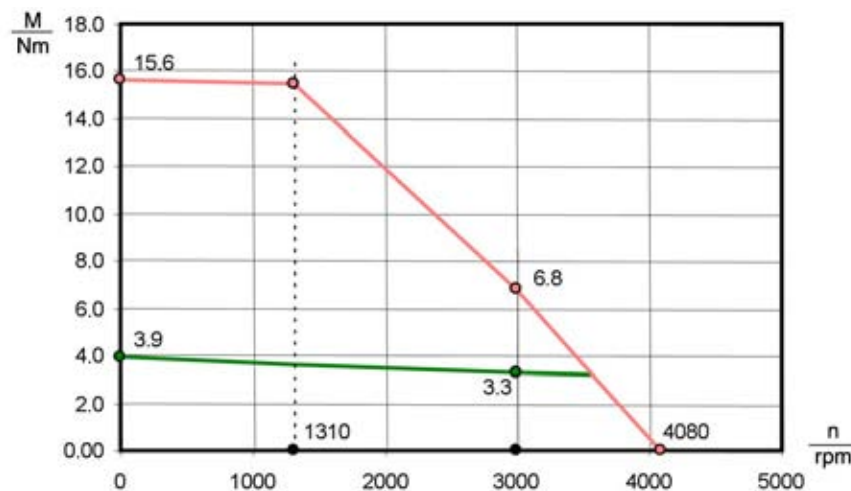

LST-097-3-30-320

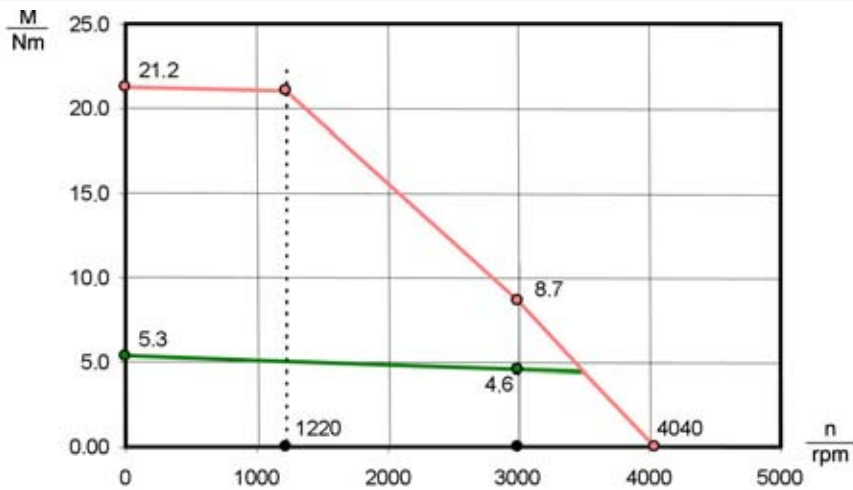

LST-097-4-30-320

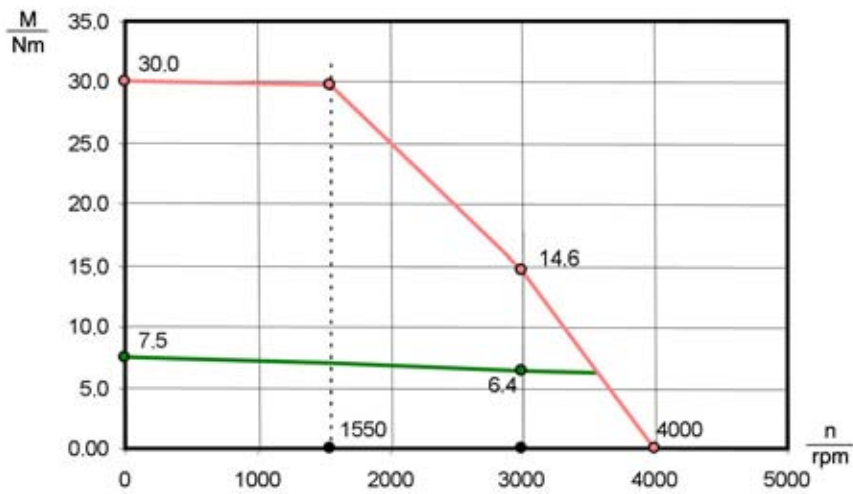

LST-097-5-30-320

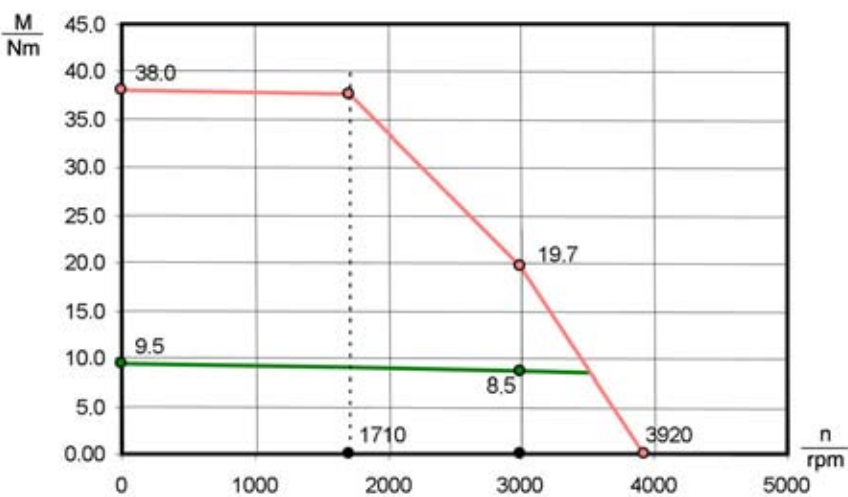

Motor type LST-097 ($U_{ZK} = 560 \text{ V}$)



Motor length [mm]	K (with resolver)	K (with optical encoder G3, G5, G12.x)	K (with optical encoder G6.x)	Additional length for version LSX-xxx-...,B (brake)
LST-097-1-30-560	146	183	167	32
LST-097-2-30-560	161	198	18	32
LST-097-3-30-560	176	213	193	32
LST-097-4-30-560	221	228	219	32
LST-097-5-30-560	236	243	234	32

Dimensional drawing

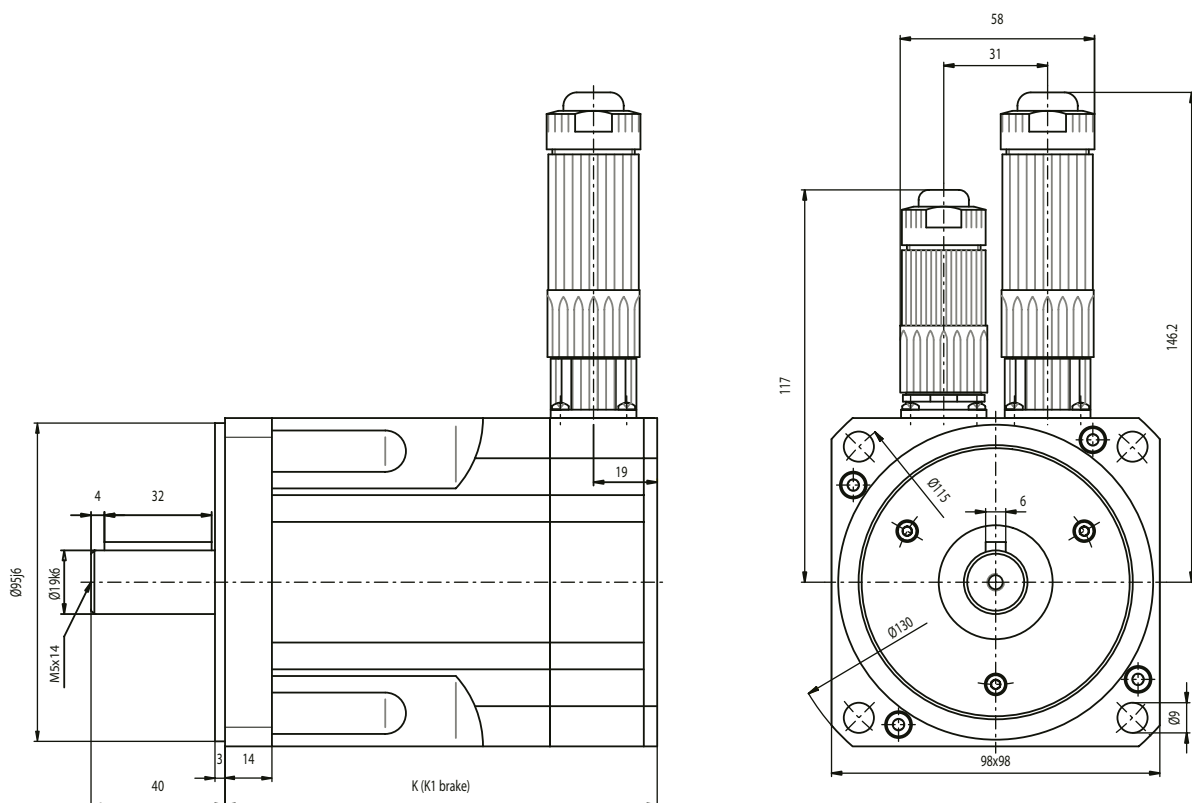

Technical data	Symbols	LST-097-1-30-560	LST-097-2-30-560	LST-097-3-30-560	LST-097-4-30-560	LST-097-5-30-560
Nominal speed	n_n	3000 rpm	3000 rpm	3000 rpm	3000 rpm	3000 rpm
Nominal frequency	f_n	150 Hz	150 Hz	150 Hz	150 Hz	150 Hz
DC link voltage (controller)	U_{dc}	560 V	560 V	560 V	560 V	560 V
Rated voltage	U_n	330 V	330 V	330 V	330 V	330 V
Nominal torque	M_n	2.3 Nm	3.3 Nm	4.6 Nm	6.4 Nm	8.5 Nm
Rated current	I_n	1.85 A	2.6 A	3.8 A	4.4 A	6.2 A
Power	P	0.72 kW	1.0 kW	1.44 kW	2.0 kW	2.67 kW
Standstill torque	M_0	2.6 Nm	3.9 Nm	5.3 Nm	7.5 Nm	9.5 Nm
Standstill current	I_0	1.92 A	2.9 A	4.1 A	4.8 A	6.6 A
Maximum permissible torque	M_{max}	10.4 Nm	15.6 Nm	21.0 Nm	30.0 Nm	38 Nm
Maximum permissible current	I_{max}	11.5 A	17.3 A	25.0 A	29 A	40 A
Maximum permissible speed	n_{max}	12000 rpm	12000 rpm	12000 rpm	12000 rpm	12000 rpm
Voltage constant	K_E	82.0 V/1000	82.0 V/1000	78.0 V/1000	94.0 V/1000	87.0 V/1000
Torque constant	K_T	1.36 Nm/A	1.36 Nm/A	1.29 Nm/A	1.55 Nm/A	1.44 Nm/A
Wicklungswiderstand (zwei Phasen)	R_{2ph}	9.6 Ω	6.3 Ω	4.2 Ω	3.0 Ω	1.65 Ω
Winding inductance (two phases)	L_{2ph}	41.5 mH	33.1 mH	24.0 mH	19.2 mH	11.7 mH
No-load speed	n_0	4020 rpm	4020 rpm	4230 rpm	3510 rpm	3790 rpm
Electrical time constant	T_{el}	4.3 ms	5.3 ms	5.7 ms	6.4 ms	7.1 ms
Thermal time constant	T_{th}	60 min.	65 min.	64 min.	66 min.	68 min.
Moment of inertia of the rotor	J	0.00019 kgm ²	0.00023 kgm ²	0.00027 kgm ²	0.00042 kgm ²	0.00061 kgm ²
Mass	m	4.5 kg	5.05 kg	5.6 kg	7.7 kg	10.5 kg
Brake (optional)						
Rated voltage	U_N	24 V \pm 10 %				
Rated current at 20 °C for release	I_N	0.75 A				
Permissible maximum speed	n_{max}	10,000 rpm				
Permissible frictional work	WR	0.89 x 10 ⁶ Ws				
Moment of inertia	J_B	0.000054 kgm ²				
Mass	m	0.46 kg				
Braking torque	M_H	9.0 Nm				

Motor type LST-097 ($U_{ZK} = 560 \text{ V}$)

Explanation of characteristic lines:

The upper characteristic line (M_{max}) describes the short-time maximum possible torque at the corresponding rotation speed (important for dynamic processes).

The lower characteristic line (M_{nenn}) shows the thermally permissible continuous torque.

LST-097-1-30-560

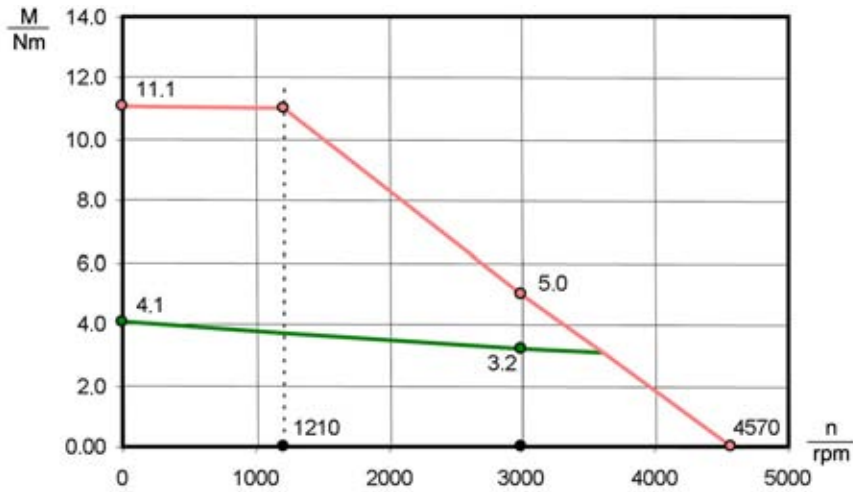

LST-097-2-30-560

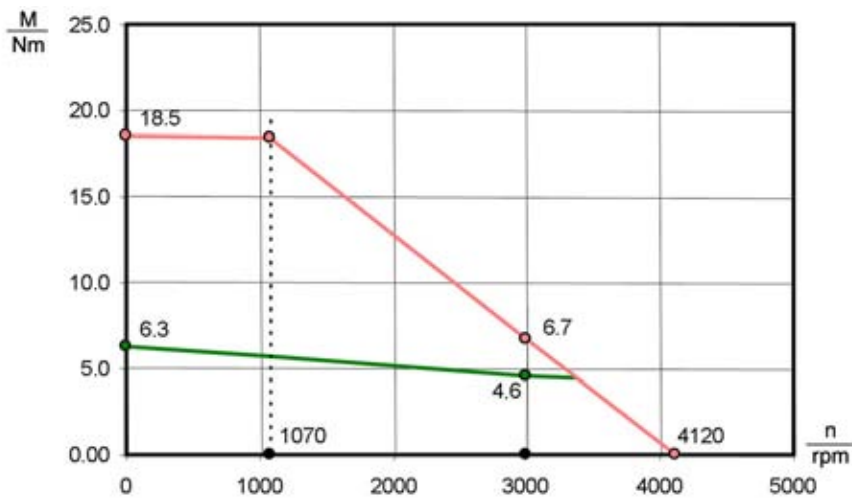

LST-097-3-30-560

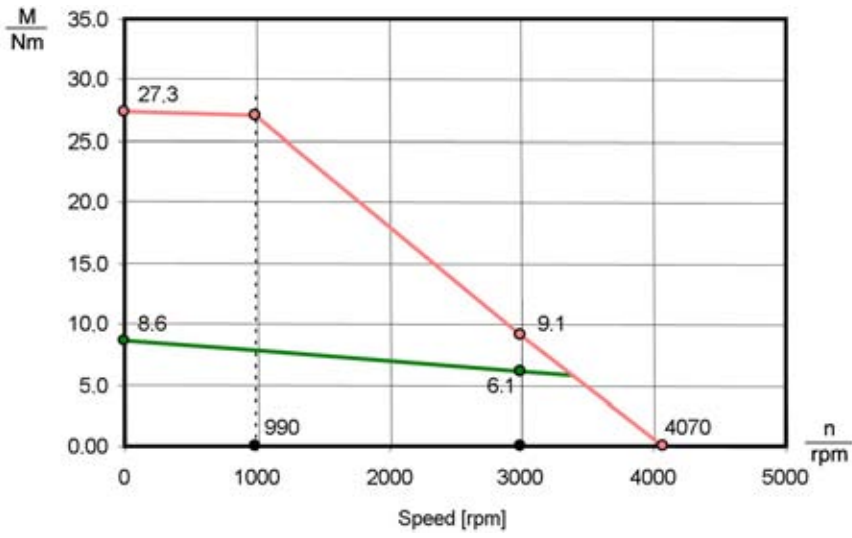

LST-097-4-30-560

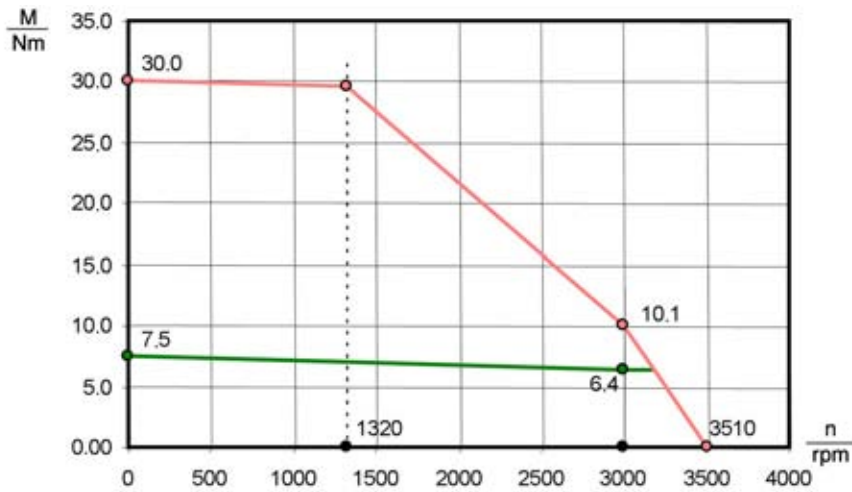

LST-097-5-30-560

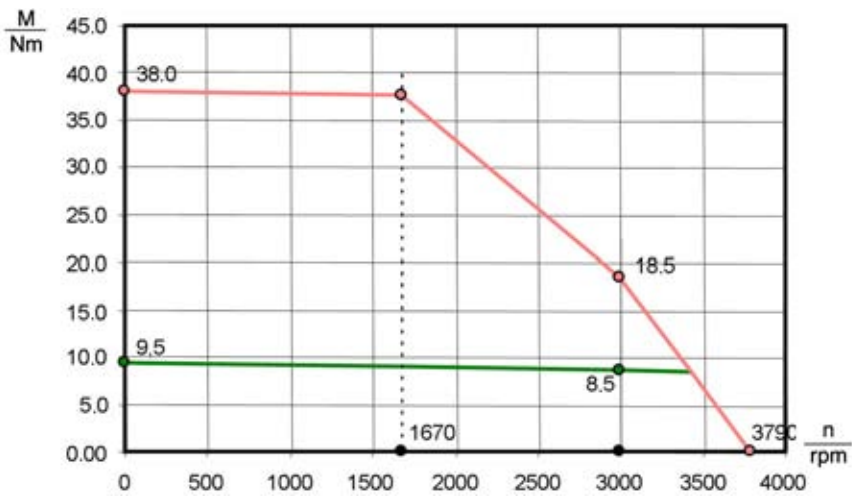

Motor type LST-127 ($U_{ZK} = 560 \text{ V}$)



Motor length [mm]	K (with resolver)	K (with optical encoder G3, G5, G12.x)	K (with optical encoder G6.x)	Additional length for version LSX-xxx-...,B (brake)
LST-127-1-30-560	185	205	188	43
LST-127-2-30-560	219	239	222	43
LST-127-3-30-560	236	256	239	43
LST-127-4-30-560	270	290	273	43
LST-127-5-30-560	304	324	307	43

Dimensional drawing

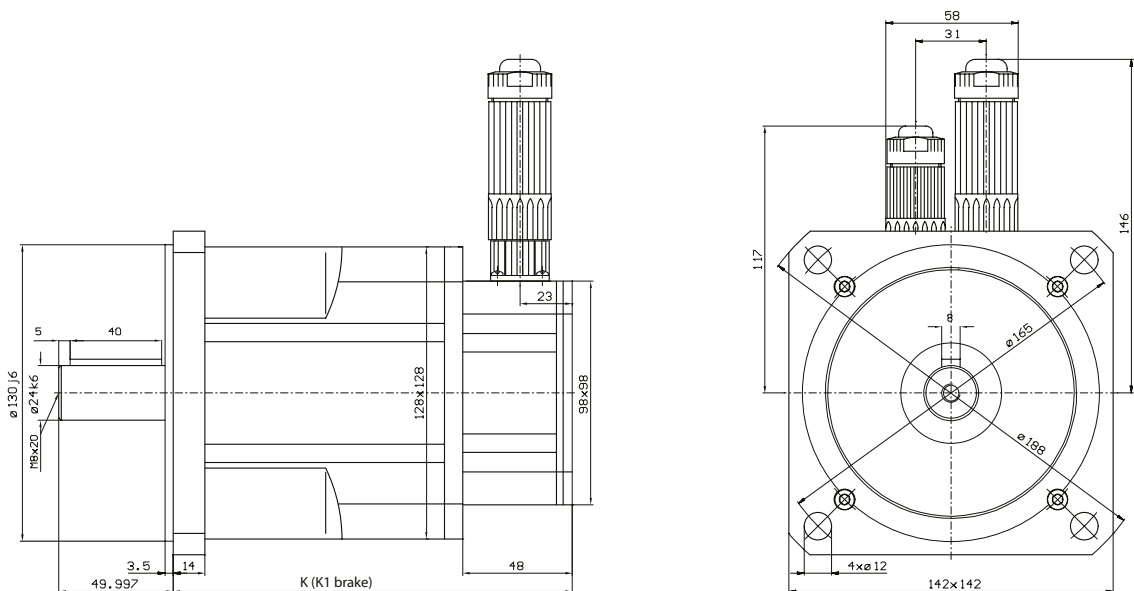

Technical data	Symbols	LST-127-1-30-560	LST-127-2-30-560	LST-127-3-30-560	LST-127-4-30-560	LST-127-5-30-560
Nominal speed	n_n	3000 rpm	3000 rpm	3000 rpm	3000 rpm	3000 rpm
Nominal frequency	f_n	150 Hz	150 Hz	150 Hz	150 Hz	150 Hz
DC link voltage (controller)	U_{dc}	560 V	560 V	560 V	560 V	560 V
Rated voltage	U_n	330 V	330 V	330 V	330 V	330 V
Nominal torque	M_n	5.7 Nm	8.8 Nm	11.0 Nm	14.0 Nm	17.0 Nm
Rated current	I_n	4.0 A	6.3 A	9.5 A	10.0 A	13.0 A
Power	P	1.79 kW	2.76 kW	3.45 kW	4.55 kW	5.33 kW
Standstill torque	M_0	6.6 Nm	10.5 Nm	13.5 Nm	17.0 Nm	22.0 Nm
Standstill current	I_0	4.5 A	7.3 A	11.2 A	11.4 A	16.4 A
Maximum permissible torque	M_{max}	19.8 Nm	32 Nm	41 Nm	51 Nm	66 Nm
Maximum permissible current	I_{max}	23 A	36 A	56 A	47 A	82 A
Maximum permissible speed	n_{max}	9000 rpm	9000 rpm	9000 rpm	9000 rpm	9000 rpm
Voltage constant	K_E	88.0 V/1000	87.0 V/1000	73.0 V/1000	90.0 V/1000	81.0 V/1000
Torque constant	K_T	1.46 Nm/A	1.44 Nm/A	1.21 Nm/A	1.49 Nm/A	1.34 Nm/A
Winding resistance (two phases)	R_{2ph}	4.20 Ω	1.70 Ω	0.95 Ω	0.95 Ω	0.54 Ω
Winding inductance (two phases)	L_{2ph}	27.8 mH	15.2 mH	9.0 mH	10.0 mH	5.9 mH
No-load speed	n_0	3750 rpm	3790 rpm	4520 rpm	3670 rpm	4070 rpm
Electrical time constant	T_{el}	6.7 ms	8.9 ms	9.5 ms	10.5 ms	10.9 ms
Thermal time constant	T_{th}	45 min.	50 min.	55 min.	60 min.	75 min.
Moment of inertia of the rotor	J	0.00059 kgm ²	0.00081 kgm ²	0.00091 kgm ²	0.00113 kgm ²	0.00117 kgm ²
Mass	m	7.5 kg	10.0 kg	11.2 kg	13.7 kg	16.2 kg
Brake (optional)						
Rated voltage	U_N	24 V \pm 10 %				
Rated current at 20 °C for release	I_N	1.0 A				
Permissible maximum speed	n_{max}	10,000 rpm				
Permissible frictional work	WR	1.29 x 10 ⁶ Ws				
Moment of inertia	J_B	0.000166 kgm ²				
Mass	m	0.9 kg				
Braking torque	M_H	18.0 Nm				

Motor type LST-127 ($U_{ZK} = 560 \text{ V}$)

Explanation of characteristic lines:

The upper characteristic line (M_{max}) describes the short-time maximum possible torque at the corresponding rotation speed (important for dynamic processes).

The lower characteristic line (M_{nenn}) shows the thermally permissible continuous torque.

LST-127-1-30-560

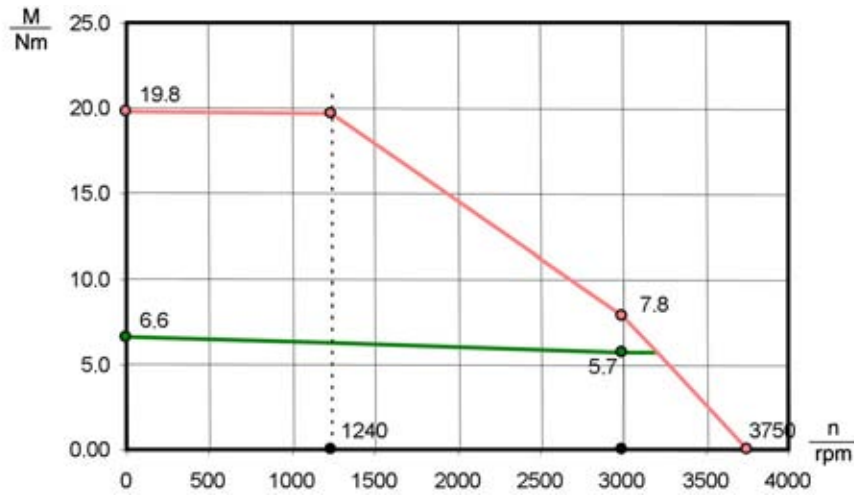

LST-127-2-30-560

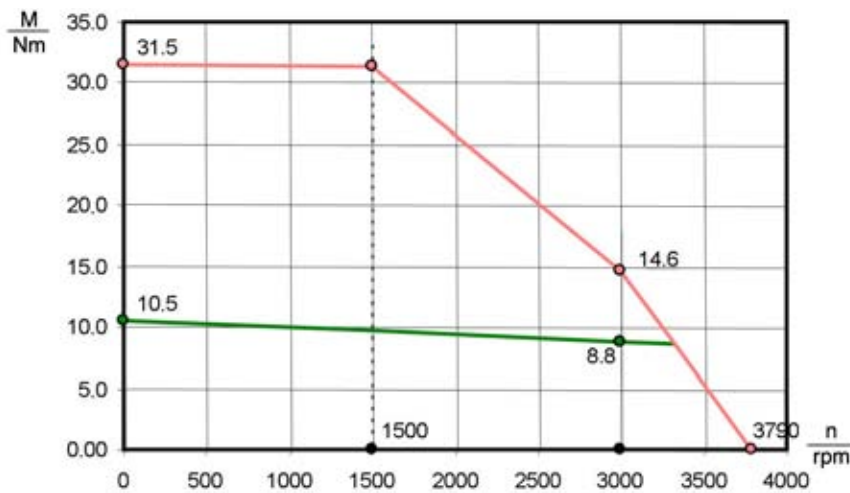

LST-127-3-30-560

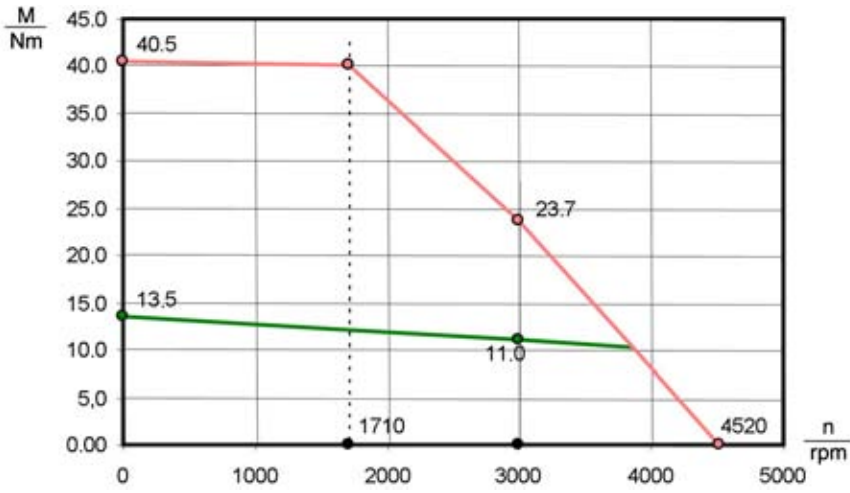

LST-127-4-30-560

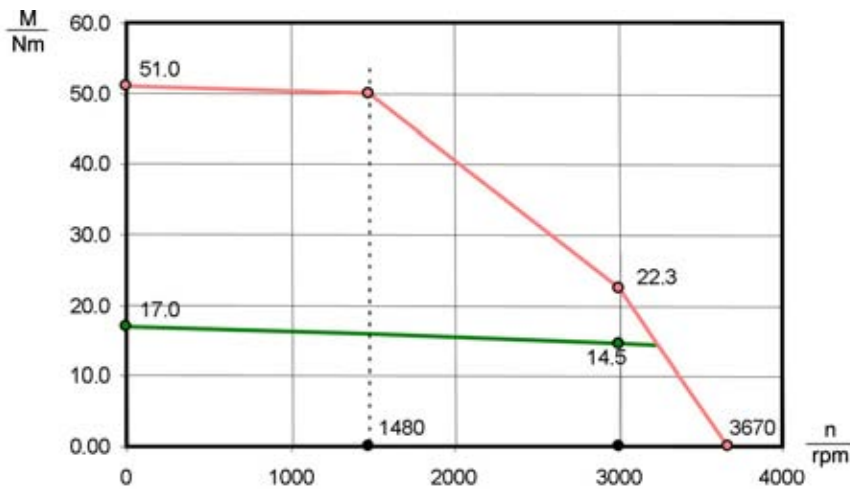

LST-127-5-30-560

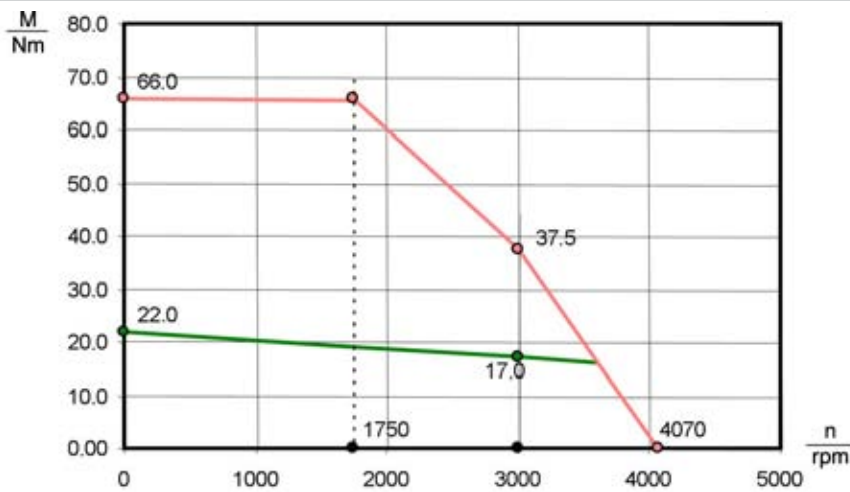

Motor type LST-158 ($U_{ZK} = 560\text{ V}$)



Motor length [mm]	K (with resolver)	K (with optical encoder G3, G5, G12.x)	K (with optical encoder G6.x)	Additional length for version LSX-xxx-...,B (brake)
LST-158-1-30-560	201	221	204	53
LST-158-2-30-560	235	255	238	53
LST-158-3-30-560	252	272	255	53
LST-158-4-30-560	310	330	313	53
LST-158-5-30-560	395	415	398	53

Dimensional drawing

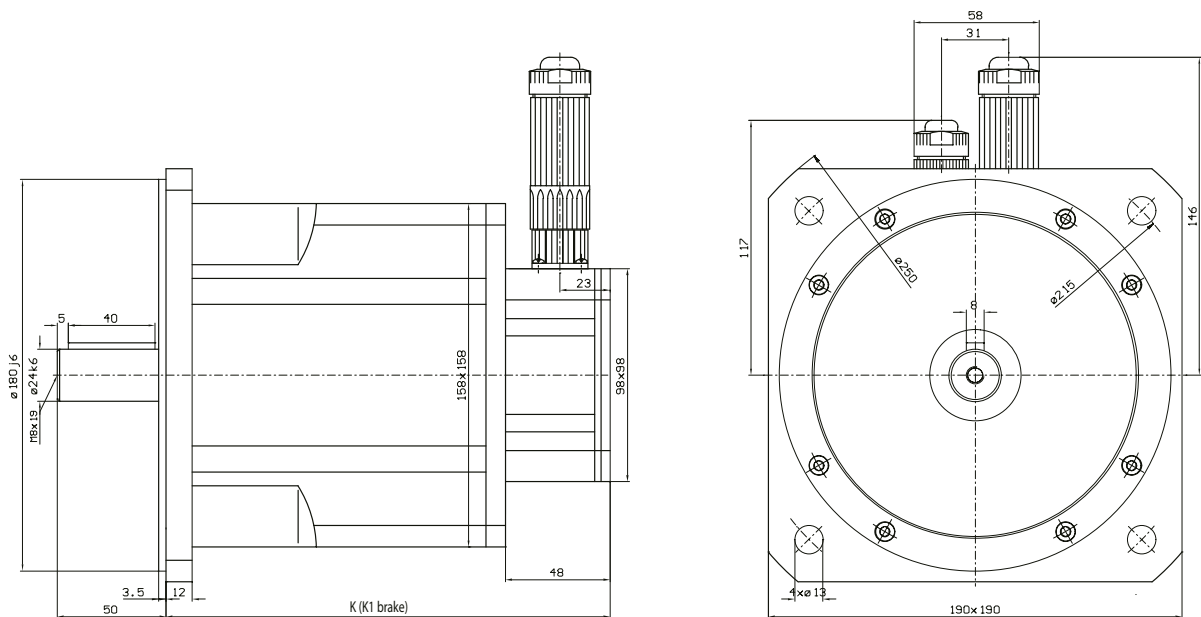

Technical data	Symbols	LST-158-1-30-560	LST-158-2-30-560	LST-158-3-30-560	LST-158-4-30-560	LST-158-5-30-560
Nominal speed	n_n	3000 rpm	3000 rpm	3000 rpm	3000 rpm	3000 rpm
Nominal frequency	f_n	150 Hz	150 Hz	150 Hz	150 Hz	150 Hz
DC link voltage (controller)	U_{dc}	560 V	560 V	560 V	560 V	560 V
Rated voltage	U_n	330 V	330 V	330 V	330 V	330 V
Nominal torque	M_n	13.0 Nm	17.0 Nm	19.0 Nm	24.0 Nm	26.0 Nm
Rated current	I_n	8.2 A	10.6 A	13.1 A	14.7 A	18.2 A
Power	P	4.0 kW	5.33 kW	6.0 kW	7.53 kW	8.16 kW
Standstill torque	M_0	13.5 Nm	19.0 Nm	22.0 Nm	29.0 Nm	35.0 Nm
Standstill current	I_0	8.2 A	11.5 A	14.6 A	17.2 A	23.5 A
Maximum permissible torque	M_{max}	47 Nm	67 Nm	77 Nm	102 Nm	105 Nm
Maximum permissible current	I_{max}	40 A	56 A	72 A	84 A	99 A
Maximum permissible speed	n_{max}	6000 rpm	6000 rpm	6000 rpm	6000 rpm	6000 rpm
Voltage constant	K_E	100.0 V/1000	100.0 V/1000	91.0 V/1000	102.0 V/1000	90.0 V/1000
Torque constant	K_T	1.65 Nm/A	1.65 Nm/A	1.51 Nm/A	1.69 Nm/A	1.49 Nm/A
Winding resistance (two phases)	R_{2ph}	1.10 Ω	0.61 Ω	0.41 Ω	0.31 Ω	0.16 Ω
Winding inductance (two phases)	L_{2ph}	13.5 mH	9.0 mH	6.4 mH	5.6 mH	3.2 mH
No-load speed	n_0	3500 rpm	3500 rpm	3500 rpm	3500 rpm	3500 rpm
Electrical time constant	T_{el}	12.3 ms	14.8 ms	15.6ms	18.1 ms	19.9 ms
Thermal time constant	T_{th}	45 min.	53 min.	60 min.	70 min.	80 min.
Moment of inertia of the rotor	J	0.00131 kgm ²	0.00187 kgm ²	0.0022 kgm ²	0.0033 kgm ²	0.0046 kgm ²
Mass	m	13.9 kg	18.2 kg	20.3 kg	26.7 kg	35.2 kgm ²
Brake (optional)						
Rated voltage	U_N	24 V \pm 10 %				
Rated current at 20 °C for release	I_N	1.1 A				
Permissible maximum speed	n_{max}	10,000 rpm				
Permissible frictional work	WR	2.90 x 10 ⁶ Ws				
Moment of inertia	J_B	0.000556 kgm ²				
Mass	m	1.6 kg				
Braking torque	M_H	36.0 Nm				

Motor type LST-158 ($U_{ZK} = 560 \text{ V}$)

Explanation of characteristic lines:

The upper characteristic line (M_{max}) describes the short-time maximum possible torque at the corresponding rotation speed (important for dynamic processes).

The lower characteristic line (M_{nenn}) shows the thermally permissible continuous torque.

3

LST-158-1-30-560

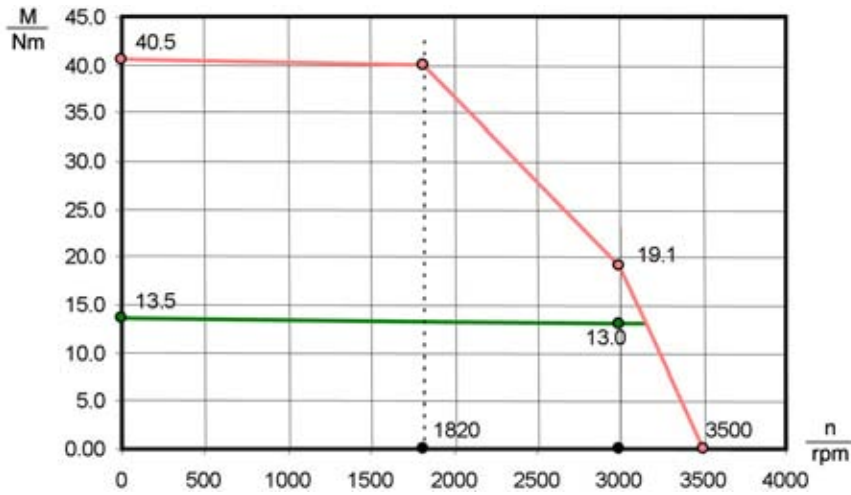

LST-158-2-30-560

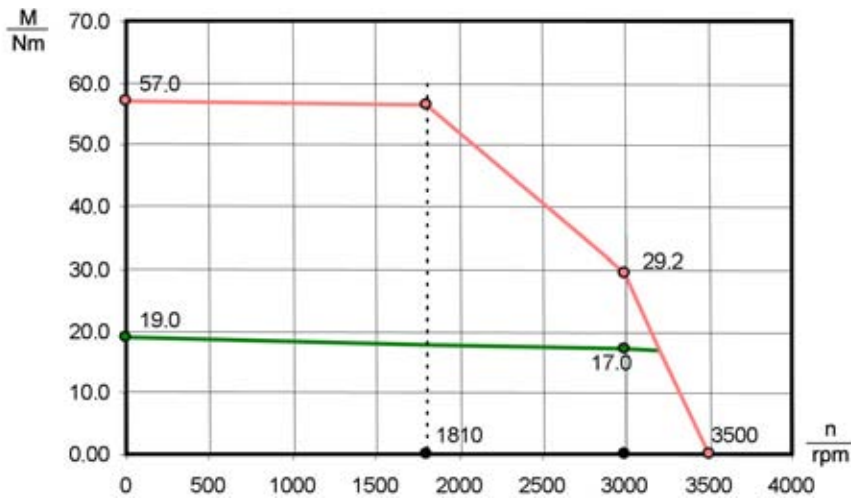

LST-158-3-30-560

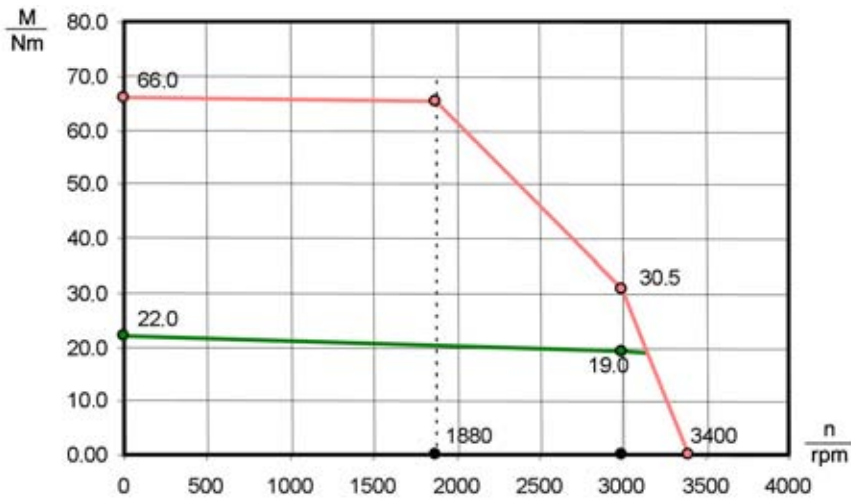

LST-158-4-30-560

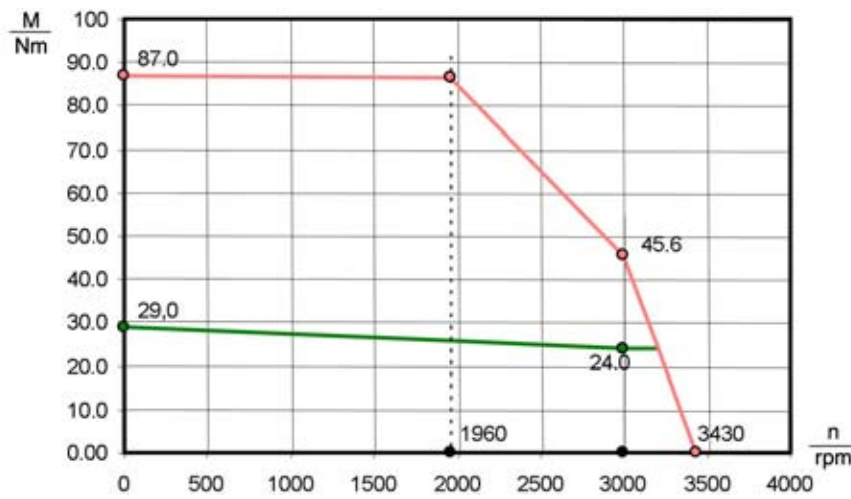

LST-158-5-30-560

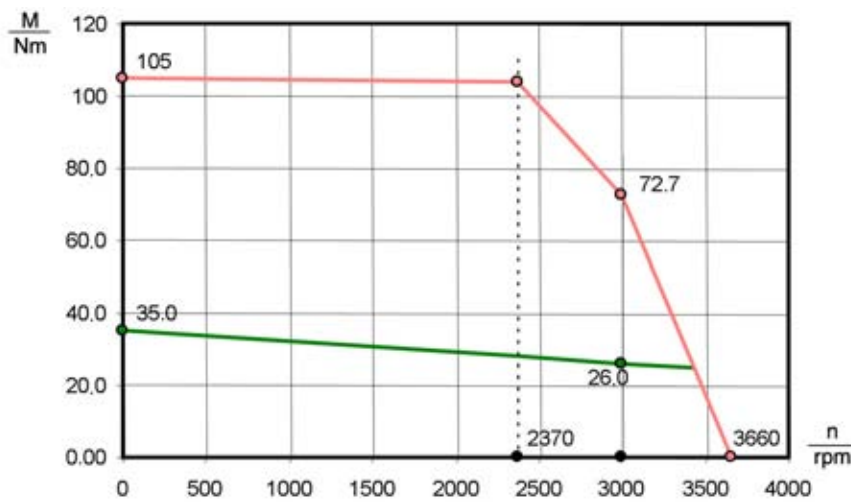

Motor type LST-190 ($U_{ZK} = 560 \text{ V}$)



Motor length [mm]	K (with resolver)	K (with optical encoder G3, G5, G12.x)	K (with optical encoder G6.x)	Additional length for version LSX-xxx-...,B (brake)
LST-190-1-30-560	242	262	245	54
LST-190-2-30-560	257	277	260	54
LST-190-3-30-560	287	307	290	54

Dimensional drawing

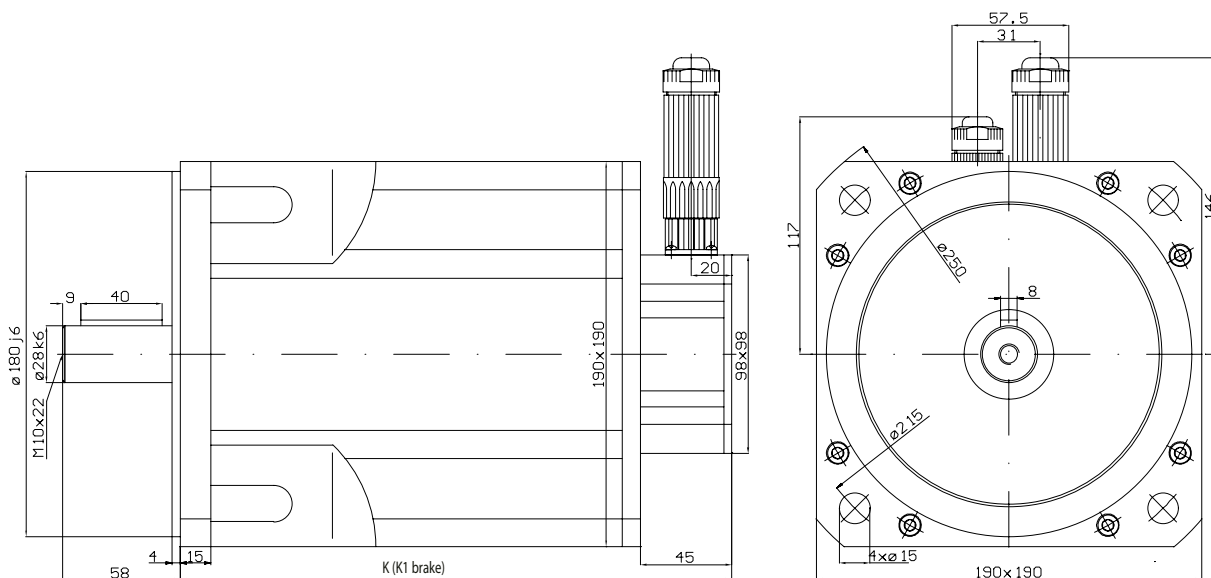

Technical data	Symbols	LST-190-1-30-560	LST-190-2-30-560	LST-190-3-30-560
Nominal speed	n_n	3000 rpm	3000 rpm	3000 rpm
Nominal frequency	f_N	150 Hz	150 Hz	150 Hz
DC link voltage (controller)	U_{dc}	560 V	560 V	560 V
Rated voltage	U_n	330 V	330 V	330 V
Nominal torque	M_n	21.0 Nm	23.0 Nm	26.0 Nm
Rated current	I_n	13.5 A	15.0 A	17.9 A
Power	P	6.6 kW	7.22 kW	8.16 kW
Standstill torque	M_0	27.0 Nm	32.0 Nm	40.0 Nm
Standstill current	I_0	16.0 A	19.0 A	24.7 A
Maximum permissible torque	M_{max}	81 Nm	96 Nm	120 Nm
Maximum permissible current	I_{max}	62 A	74 A	96 A
Maximum permissible speed	n_{max}	6000 rpm	6000 rpm	6000 rpm
Voltage constant	K_E	102.0 V/1000	102.0 V/1000	98.0 V/1000
Torque constant	K_T	1.69 Nm/A	1.69 Nm/A	1.62 Nm/A
Winding resistance (two phases)	R_{2ph}	0.43 Ω	0.35 Ω	0.23 Ω
Winding inductance (two phases)	L_{2ph}	4.4 mH	3.8 mH	2.7 mH
No-load speed	n_0	3230 rpm	3230 rpm	3360 rpm
Electrical time constant	T_{el}	10.2 ms	10.9 ms	11.7 ms
Thermal time constant	T_{th}	60 min.	67 min.	67 min.
Moment of inertia of the rotor	J	0.0036 kgm ²	0.0039 kgm ²	0.0046 kgm ²
Mass	m	23.5 kg	26.0 kg	31.5 kg
Brake (optional)				
Rated voltage	U_N	24 V \pm 10 %		
Rated current at 20 °C for release	I_N	1.1 A		
Permissible maximum speed	n_{max}	10,000 rpm		
Permissible frictional work	WR	2.9 10 ⁶ Ws		
Moment of inertia	J_B	0.00062 kgm ²		
Mass	m	3.2 kg		
Braking torque	M_H	36 Nm		

Motor type LST-190 ($U_{ZK} = 560 \text{ V}$)

Explanation of characteristic lines:

The upper characteristic line (M_{max}) describes the short-time maximum possible torque at the corresponding rotation speed (important for dynamic processes).

The lower characteristic line (M_{nenn}) shows the thermally permissible continuous torque.

LST-190-1-30-560

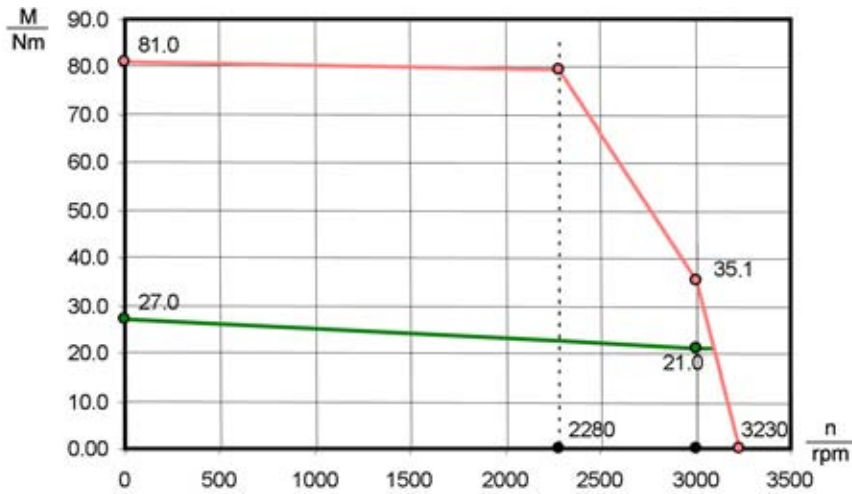

LST-190-2-30-560

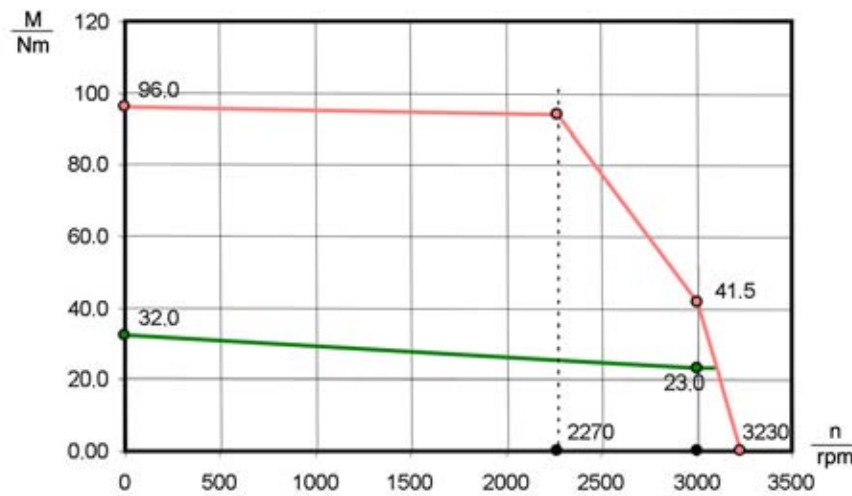

LST-190-3-30-560

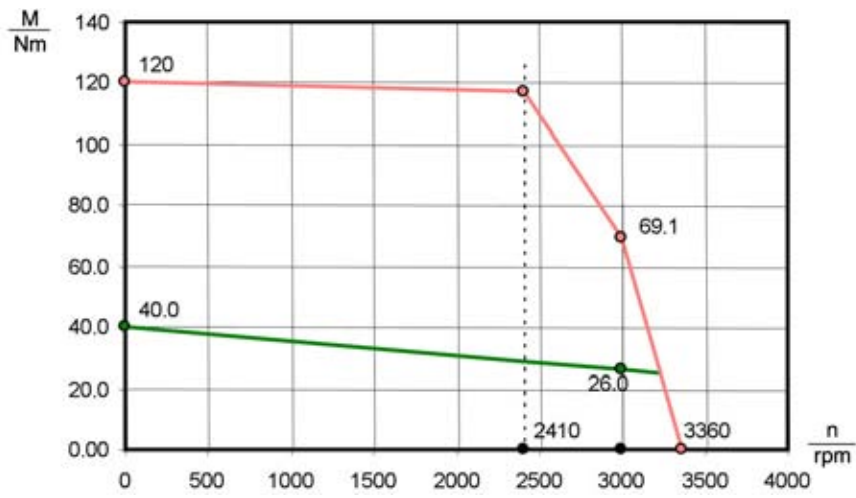

Motor type LST-220 ($U_{ZK} = 560 \text{ V}$)



Motor length [mm]	K (with resolver)	K (with optical encoder G3, G5, G12.x)	K (with optical encoder G6.x)	Additional length for version LSX-xxx-...,B (brake)
LST-220-1-30-560	310	322	312	69
LST-220-2-30-560	378	390	380	69
LST-220-3-30-560	446	458	448	69
LST-220-4-30-560	514	526	516	69

Dimensional drawing

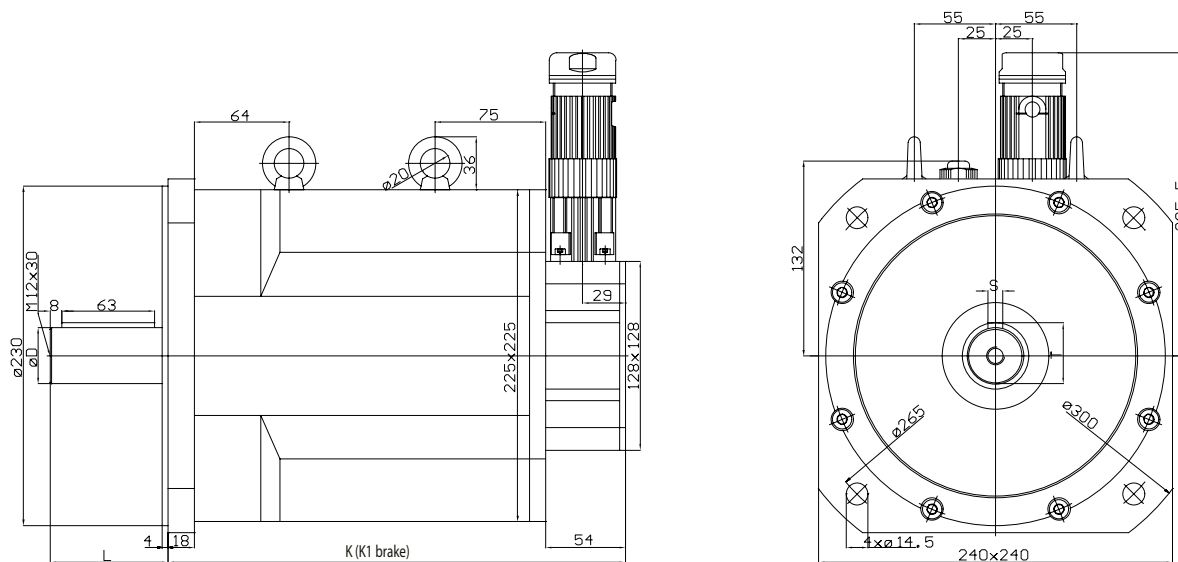

Technical data	Symbols	LST-220-1-30-560	LST-220-2-30-560	LST-220-3-30-560	LST-220-4-30-560
Nominal speed	n_n	3000 rpm	3000 rpm	3000 rpm	3000 rpm
Nominal frequency	f_N	150 Hz	150 Hz	150 Hz	150 Hz
DC link voltage (controller)	U_{dc}	560 V	560 V	560 V	560 V
Rated voltage	U_n	355 V	330 V	330 V	350 V
Nominal torque	M_n	30 Nm	50 Nm	60 Nm	50 Nm
Rated current	I_n	17.8 A	31.1 A	43.6 A	29.3 A
Power	P	9.42 kW	15.7 kW	18.84 kW	15.7 kW
Standstill torque	M_0	40 Nm	68 Nm	93 Nm	115 Nm
Standstill current	I_0	21.8 A	39.9 A	66 A	63 A
Maximum permissible torque	M_{max}	120 Nm	204 Nm	279 Nm	345 Nm
Maximum permissible current	I_{max}	85 A	156 A	258 A	247 A
Maximum permissible speed	n_{max}	3600 rpm	3600 rpm	3600 rpm	3600 rpm
Voltage constant	K_E	111.0 V/1000	103.0 V/1000	85.0 V/1000	110.0 V/1000
Torque constant	K_T	1.84 Nm/A	1.7 Nm/A	1.41 Nm/A	1.82 Nm/A
Winding resistance (two phases)	R_{2ph}	0.25 Ω	0.10 Ω	0.04 Ω	0.05 Ω
Winding inductance (two phases)	L_{2ph}	5.7 mH	2.5 mH	1.2 mH	1.5 mH
No-load speed	n_0	3190 rpm	3200 rpm	3880 rpm	3180 rpm
Electrical time constant	T_{el}	23 ms	25 ms	30 ms	30 ms
Thermal time constant	T_{th}	47 min.	65 min.	79 min.	90 min.
Moment of inertia of the rotor	J	0.0076 kgm ²	0.0114 kgm ²	0.0153 kgm ²	0.0190 kgm ²
Mass	m	41 kg	56 kg	73 kg	89 kg
Brake (optional)					
Rated voltage	U_N	24 V \pm 10 %			
Rated current at 20 °C for release	I_N	2.1 A			
Permissible maximum speed	n_{max}	10,000 rpm			
Permissible frictional work	WR	13 x 10 ⁶ Ws			
Moment of inertia	J_B	0.0056 kgm ²			
Mass	m	9.5 kg			
Braking torque	M_H	145 Nm			

Motor type LST-220 ($U_{ZK} = 560 \text{ V}$)

Explanation of characteristic lines:

The upper characteristic line (M_{max}) describes the short-time maximum possible torque at the corresponding rotation speed (important for dynamic processes).

The lower characteristic line (M_{nenn}) shows the thermally permissible continuous torque.

LST-220-1-30-560

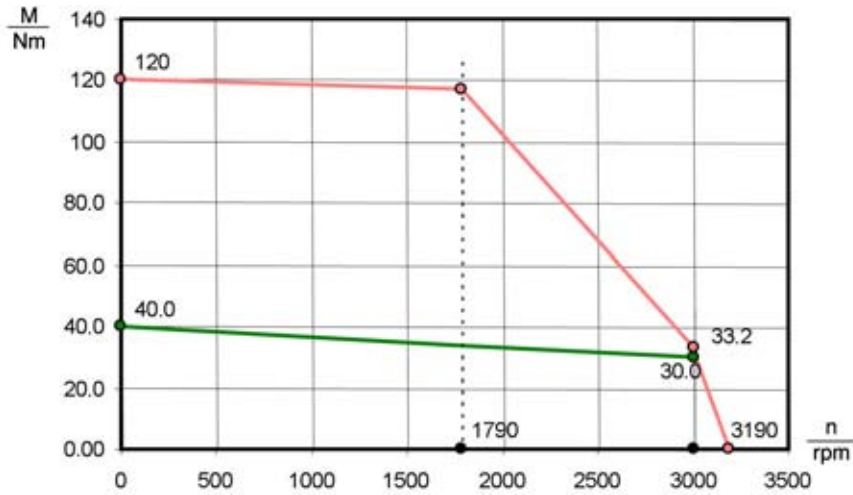

LST-220-2-30-560

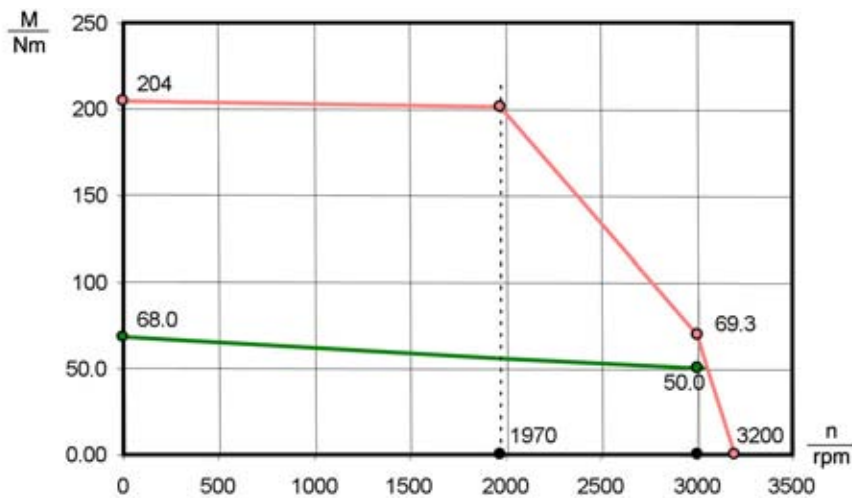

LST-220-3-30-560

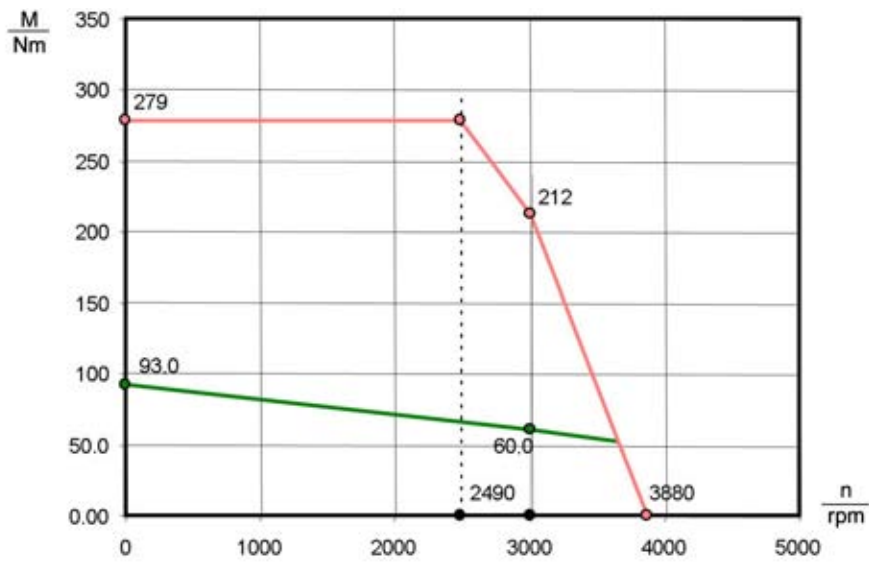

LST-220-4-30-560

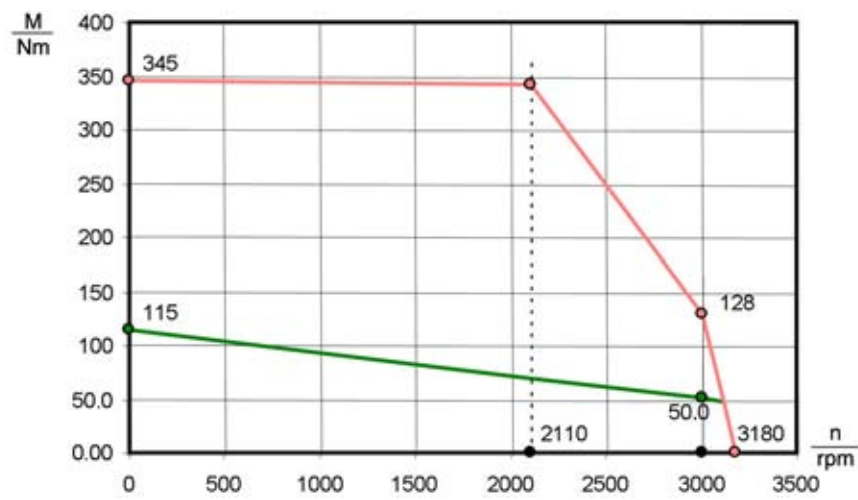

Area for your notes:

LSx servomotors with 24 V and 48 V windings, overview

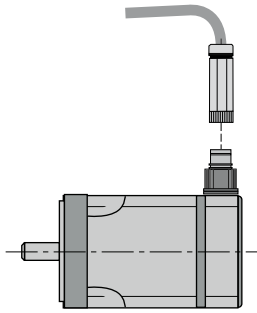

Typ	U _{DC}	Page
LST-037	24/48 V	4 - 2
LSH-050	24/48 V	4 - 6
LSH-74	24/48 V	4 - 10

LSx- motors – for functional extra-low voltage

The servomotors in the LSH and LST ranges are also available with motor windings for functional extra-low voltage to IEC 364 (VDE 0100, part 410). Together with the CDF3000 servo controller, they offer the optimum combination for this voltage range.

Technical data, motor	Standstill torque M ₀ [Nm]	Nominal torque M _N [Nm]	Rated current at 24 V I _N [A]	Rated current at 48 V I _N [A]	Nominal speed n _N [rpm]	
					at 24 V	at 48 V
LST-037-1-80-24	0.10	0.09	5.4	5.4	8000	8000
LST-037-2-60-24	0.20	0.18	6.9	6.9	6000	6000
LSH-050-1-30-48	0.26	0.25		3.2	1000	3000
LSH-050-2-30-48	0.50	0.47	5.5	5.4	1000	3000
LSH-050-3-30-48	0.70	0.67	7.1	6.9	1000	3000
LSH-074-1-15-24	0.80	0.75	8.3	8.3	1500	1500

Motor type LST-037-x-xx-24



Motor length [mm]	K (with resolver)	K (with optical encoder G3/G5)	K (with optical encoder G6/G6M)	Additional length for version LSX-xxx-...,B (brake)
LST-037-1-80-24	67	130.5	98	38
LST-037-2-80-24	82	145.5	113	38

Dimensional drawing

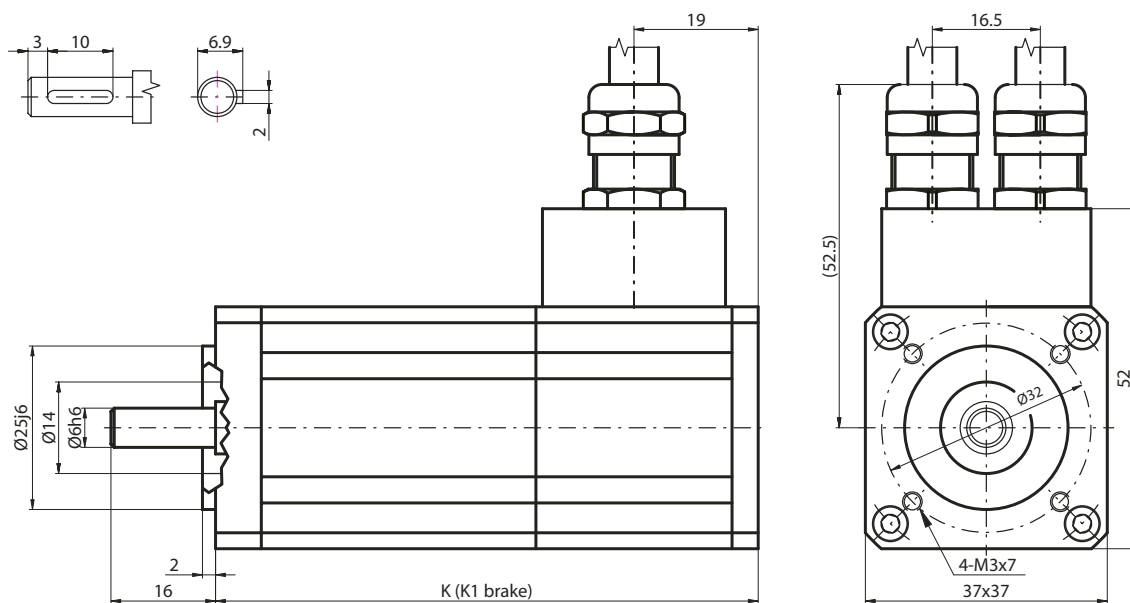

Technical data	Symbols	LST-037-1-80-24		LST-037-2-60-24	
		at UZK = 24 V	at UZK = 48 V	at UZK = 24 V	at UZK = 48 V
Nominal speed	n_n	8000 rpm	8000 rpm	6000 rpm	6000 rpm
Nominal frequency	f_N	400 Hz	400 Hz	300 Hz	300 Hz
DC link voltage (controller)	U_{dc}	24 V	48 V	24 V	48 V
Rated voltage	U_n	15 V	30 V	15 V	30 V
Nominal torque	M_n	0.09 Nm	0.09 Nm	0.18 Nm	0.18 Nm
Rated current	I_n	5.4 A	5.4 A	6.9 A	6.9 A
Power	P	0.075 kW	0.075 kW	0.11 kW	0.11 kW
Standstill torque	M_0	0.10 Nm	0.10 Nm	0.20 Nm	0.20 Nm
Standstill current	I_0	5.5 A	5.5 A	7.1 A	7.1 A
Maximum permissible torque	M_{max}	0.40 Nm	0.40 Nm	0.80 Nm	0.80 Nm
Maximum permissible current	I_{max}	24 A	24 A	31 A	31 A
Maximum permissible speed	n_{max}	12000 rpm	12000 rpm	12000 rpm	12000 rpm
Voltage constant	K_E	1.1 V/1000	1.1 V/1000	1.7 V/1000	1.7 V/1000
Torque constant	K_T	0.02 Nm/A	0.02 Nm/A	0.03 Nm/A	0.03 Nm/A
Winding resistance (two phases)	R_{2ph}	0.42 Ω	0.42 Ω	0.34 Ω	0.34 Ω
Winding inductance (two phases)	L_{2ph}	0.10 mH	0.10 mH	0.10 mH	0.10 mH
No-load speed	n_0	13640 rpm	27520 rpm	8820 rpm	17700 rpm
Electrical time constant	T_{el}	0.24 ms	0.24 ms	0.29 ms	0.29 ms
Thermal time constant	T_{th}	18 min	18 min	20 min	20 min
Moment of inertia of the rotor	J	0.000006 kgm ²	0.000006 kgm ²	0.000006 kgm ²	0.000006 kgm ²
Mass	m	0.37 kg	0.37 kg	0.45 kg	0.45 kg
Brake (optional)					
Rated voltage $\pm 10\%$	U_M	24 V $\pm 10\%$			
Rated current at 20 °C for release	I_N	0.33 A			
Permissible maximum speed	n_{max}	10,000 rpm			
Permissible frictional work	WR	0.20 x 10 ⁶ Ws			
Moment of inertia	J_B	0.000013 kgm ²			
Mass	m	0.075 kg			
Braking torque	M_H	0.4 Nm			

Motor type LST-037-x-xx-24

Explanation of characteristic lines:

The upper characteristic line (M_{max}) describes the short-time maximum possible torque at the corresponding rotation speed (important for dynamic processes).

The lower characteristic line (M_{nenn}) shows the thermally permissible continuous torque.

The motors can be operated at either 24 V or 48 V.

LST-037-1-80-24 $U_{zk} = 24\text{ V}$

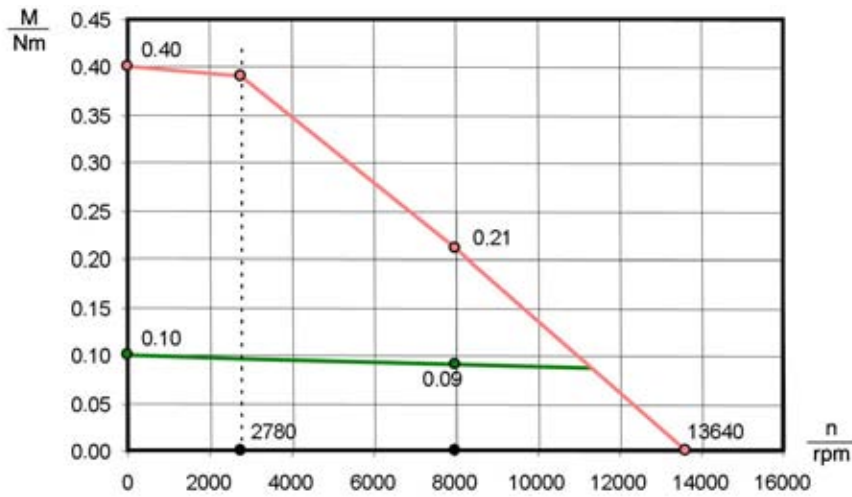

LST-037-1-80-24 $U_{zk} = 48\text{ V}$

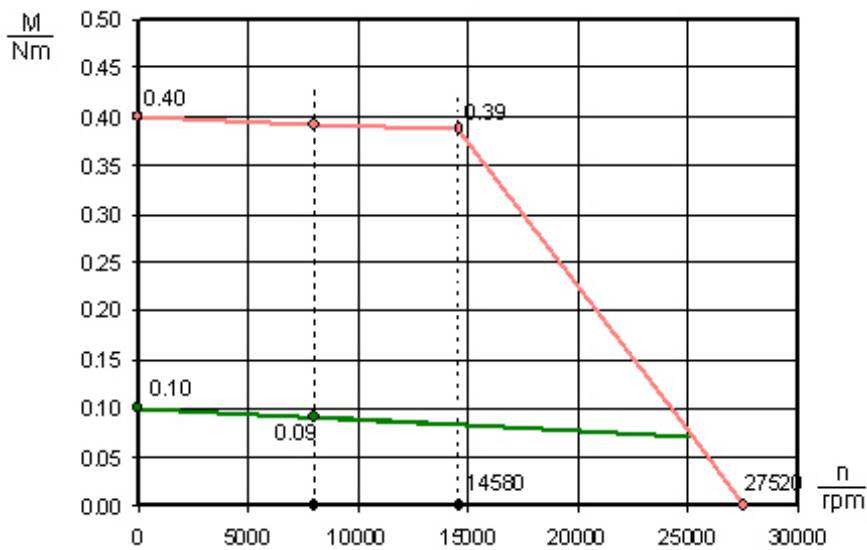

LST-037-2-60-24 $U_{zK} = 24\text{ V}$

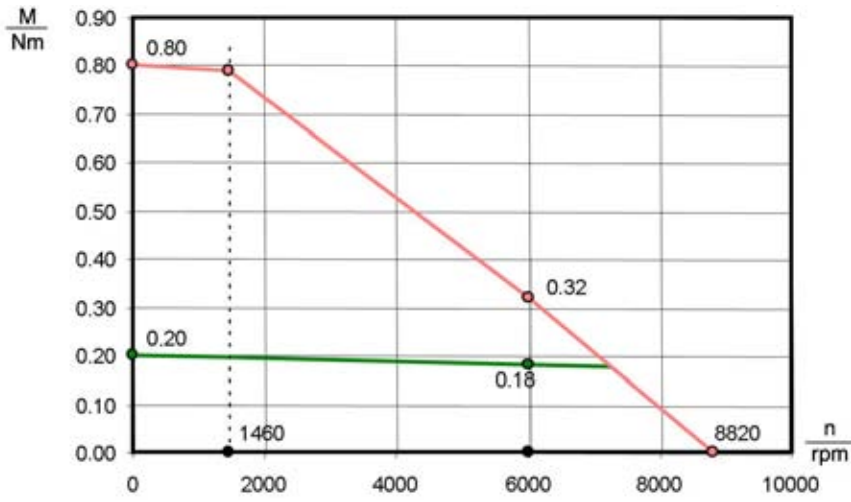

LST-037-2-60-24 $U_{zK} = 48\text{ V}$

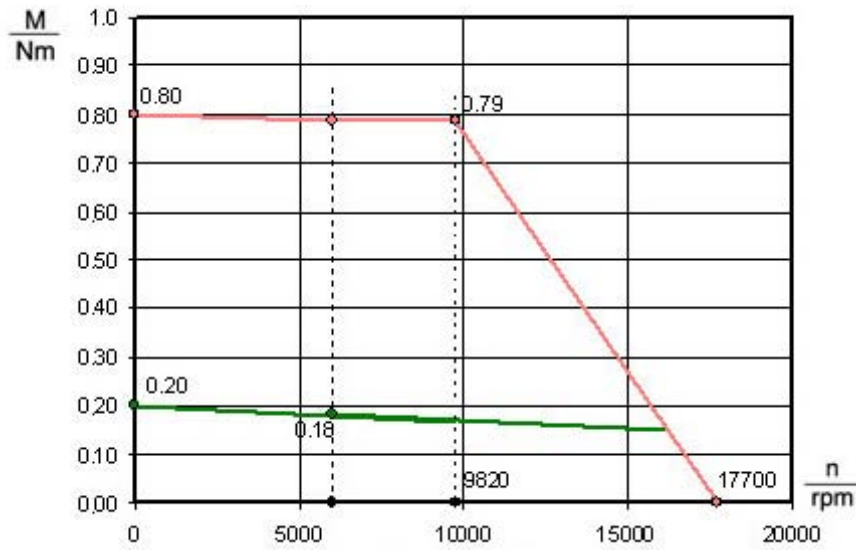

Motor type LSH-050-x-30-48 ($U_{zK} = 24\text{ V}$)



Motor length [mm]	K (with resolver)	K (with optical encoder G12.2x)	K (with optical encoder G6.2x)	Additional length for version LSX-xxx-...,B (brake)
LSH-050-1-30-48	67		90	38
LSH-050-2-30-48	82	not available!	105	38
LSH-050-3-30-48	97		120	38

Dimensional drawing

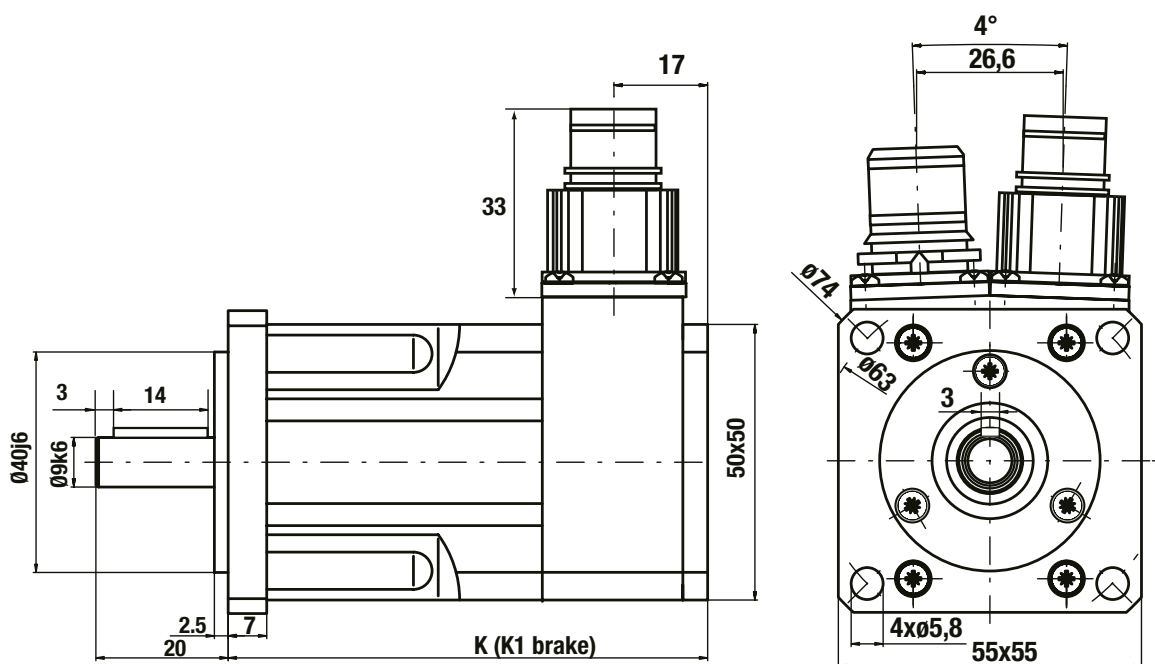

Technical data	Symbols	LST-050-1-30-48 U _{ZK} 24	LST-050-2-30-48 U _{ZK} 24	LST-050-3-30-48 U _{ZK} 24
Nominal speed	n_n	1000 rpm	1000 rpm	1000 rpm
Nominal frequency	f_n	50 Hz	50 Hz	50 Hz
DC link voltage (controller)	U_{dc}	24 V	24 V	24 V
Rated voltage	U_n	15 V	15 V	15 V
Nominal torque	M_n	0.25 Nm	0.50 Nm	0.70 Nm
Rated current	I_n	3.1 A	5.5 A	7.1 A
Power	P	0.026 kW	0.052 kW	0.076 kW
Standstill torque	M_0	0.26 Nm	0.50 Nm	0.70 Nm
Standstill current	I_0	3.0 A	5.5 A	7.1 A
Maximum permissible torque	M_{max}	0.56 Nm	1.4 Nm	2.0 Nm
Maximum permissible current	I_{max}	6.8 A	15.5 A	
Maximum permissible speed	n_{max}	12000 rpm	12000 rpm	12000 rpm
Voltage constant	K_E	5.0 V/1000	5.5 V/1000	6.0 V/1000
Torque constant	K_T	0.08 Nm/A	0.09 Nm/A	0.10 Nm/A
Winding resistance (two phases)	R_{2ph}	1.8 Ω	0.8 Ω	0.6 Ω
Winding inductance (two phases)	L_{2ph}	3.1 mH	1.5 mH	1.10 mH
No-load speed	n_0	2930 rpm	2690 rpm	2500 rpm
Electrical time constant	T_{el}	1.7 ms	1.8 ms	1.8 ms
Thermal time constant	T_{th}	13 min.	15 min.	20 min.
Moment of inertia of the rotor	J	0.06 kgcm ²	0.000008 kgm ²	0.00001 kgm ²
Mass	m	0.75 kg	0.92 kg	1.09 kg
Brake (optional)				
Rated voltage $\pm 10\%$	U_M		24 V $\pm 10\%$	
Rated current at 20 °C for release	I_N		0.46 A	
Permissible maximum speed	n_{max}		10,000 rpm	
Permissible frictional work	WR		0.41 x 10 ⁶ Ws	
Moment of inertia	J_B		0.000007 kgm ²	
Mass	m		0.15 kg	
Braking torque	M_H		2 Nm	

Motor type LSH-050-x-30-48 ($U_{ZK} = 24\text{ V}$)

Explanation of characteristic lines:

The upper characteristic line (M_{max}) describes the short-time maximum possible torque at the corresponding rotation speed (important for dynamic processes).

The lower characteristic line (M_{nenn}) shows the thermally permissible continuous torque.

The motors can be operated at either 24 V or 48 V.

LSH-050-1-30-48 $U_{ZK} = 24\text{ V}$

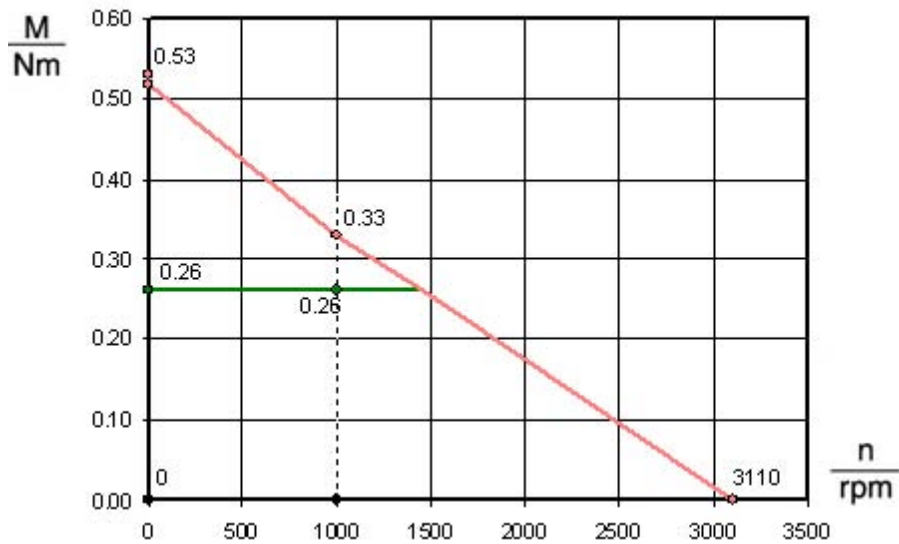

LSH-050-2-30-48 $U_{ZK} = 24\text{ V}$

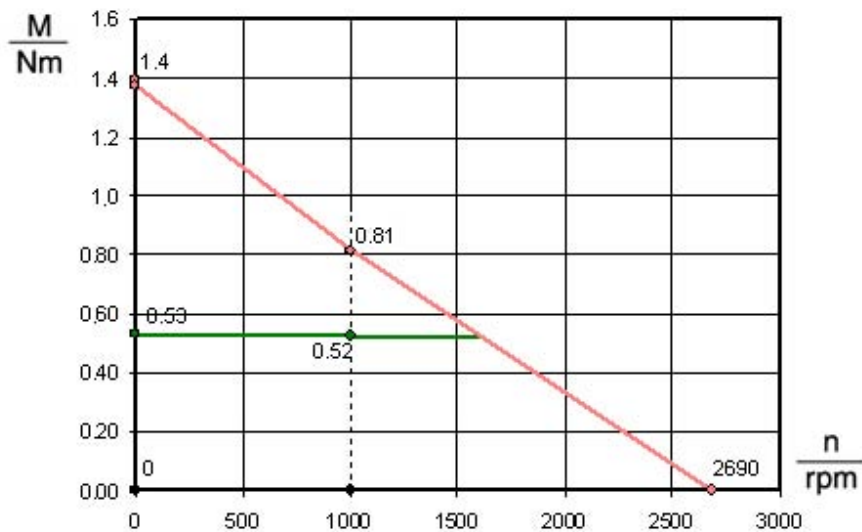

LSH-050-3-30-48 $U_{zK} = 24\text{ V}$

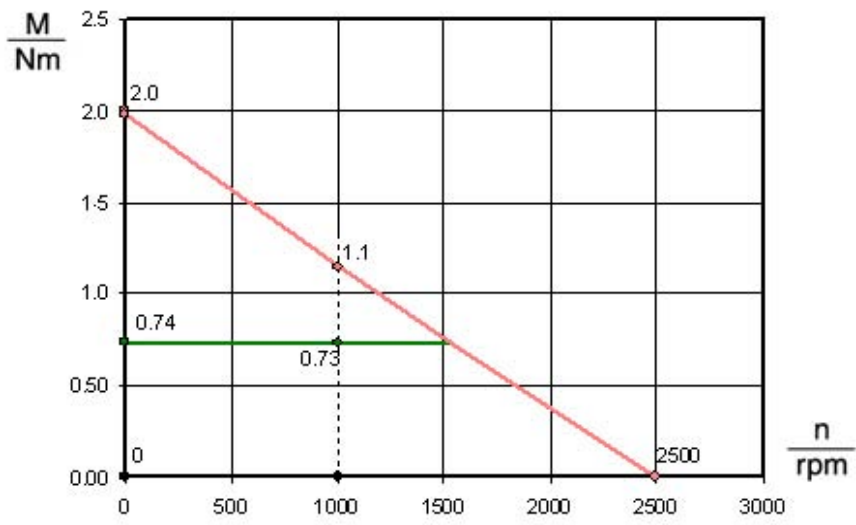

Motor type LSH-050-x-30-48 ($U_{zK} = 48 \text{ V}$)



Motor length [mm]	K (with resolver)	K (with optical encoder G12.2x)	K (with optical encoder G6.2x)	Additional length for version LSX-xxx-...,B (brake)
LSH-050-1-30-48	67		90	38
LSH-050-2-30-48	82	not available!	105	38
LSH-050-3-30-48	97		120	38

Dimensional drawing

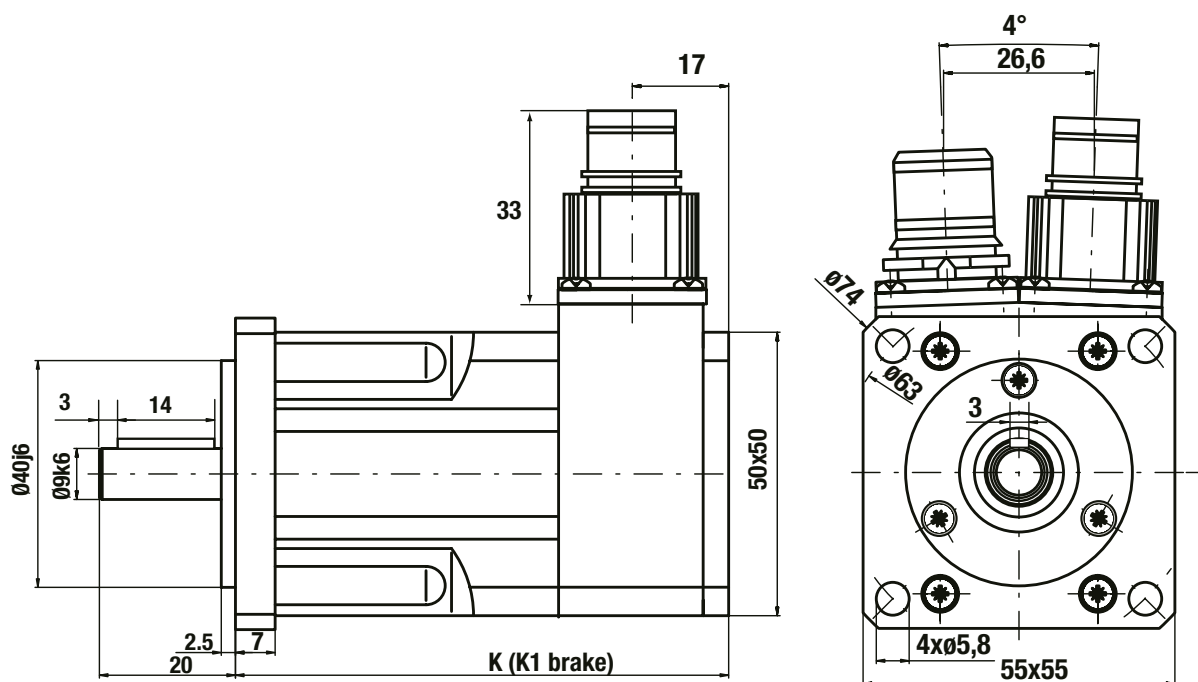

Technical data	Symbols	LST-050-1-30-48 U _{ZK} 48	LST-050-2-30-48 U _{ZK} 48	LST-050-3-30-48 U _{ZK} 48
Nominal speed	n_n	3000 rpm	3000 rpm	3000 rpm
Nominal frequency	f_n	150 Hz	150 Hz	150 Hz
DC link voltage (controller)	U_{dc}	48 V	48 V	48 V
Rated voltage	U_n	30 V	30 V	30 V
Nominal torque	M_n	0.25 Nm	0.49 Nm	0.70 Nm
Rated current	I_n	3.2 A	5.6 A	7.3 A
Power	P	0.078 kW	0.154 kW	0.022 kW
Standstill torque	M_0	0.26 Nm	0.53 Nm	0.74 Nm
Standstill current	I_0	3.1 A	5.8 A	7.5 A
Maximum permissible torque	M_{max}	1.0 Nm	2.0 Nm	2.8 Nm
Maximum permissible current	I_{max}	13.0 A	24 A	31 A
Maximum permissible speed	n_{max}	12000 rpm	12000 rpm	12000 rpm
Voltage constant	K_E	5.0 V/1000	5.5 V/1000	6.0 V/1000
Torque constant	K_T	0.08 Nm/A	0.09 Nm/A	0.10 Nm/A
Winding resistance (two phases)	R_{2ph}	1.83 Ω	0.83 Ω	0.6 Ω
Winding inductance (two phases)	L_{2ph}	3.1 mH	1.6 mH	1.10 mH
No-load speed	n_0	5910 rpm	5400 rpm	5010 rpm
Electrical time constant	T_{el}	1.7 ms	1.9 ms	1.8 ms
Thermal time constant	T_{th}	13 min.	15 min.	20 min.
Moment of inertia of the rotor	J	0.000006 kgm ²	0.000008 kgm ²	0.00001 kgm ²
Mass	m	0.75 kg	0.92 kg	1.09 kg
Brake (optional)				
Rated voltage \pm 10 %	U_M		24 V \pm 10 %	
Rated current at 20 °C for release	I_N		0.46 A	
Permissible maximum speed	n_{max}		10,000 rpm	
Permissible frictional work	WR		0.41 x 10 ⁶ Ws	
Moment of inertia	J_B		0.07 kgcm ²	
Mass	m		0.15 kg	
Braking torque	M_H		2 Nm	

Motor type LSH-050-x-30-48 ($U_{zK} = 48 \text{ V}$)

Explanation of characteristic lines:

The upper characteristic line (M_{max}) describes the short-time maximum possible torque at the corresponding rotation speed (important for dynamic processes).

The lower characteristic line (M_{nenn}) shows the thermally permissible continuous torque.

The motors can be operated at either 24 V or 48 V.

LSH-050-1-30-48 $U_{zK} = 48 \text{ V}$

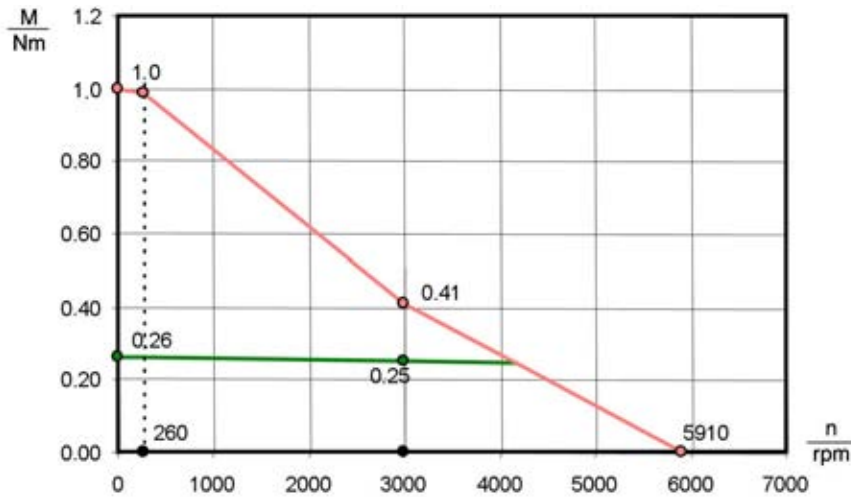

LSH-050-2-30-48 $U_{zK} = 48 \text{ V}$

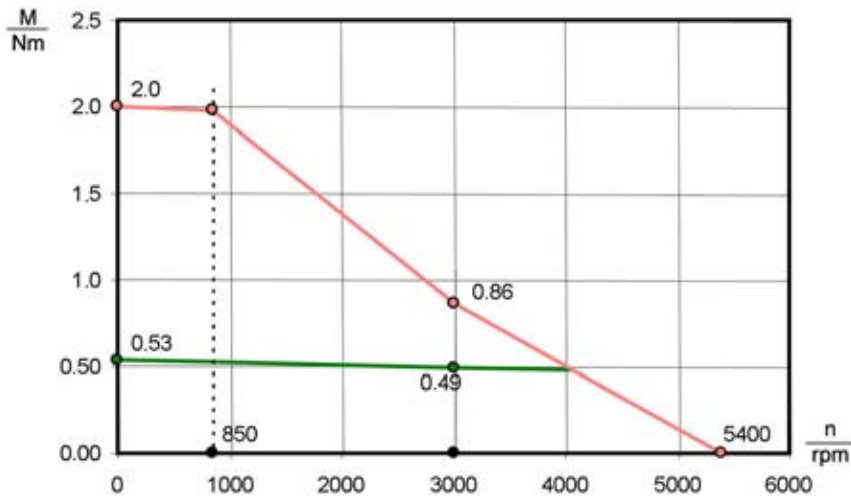

LSH-050-3-30-48 $U_{zK} = 48 \text{ V}$

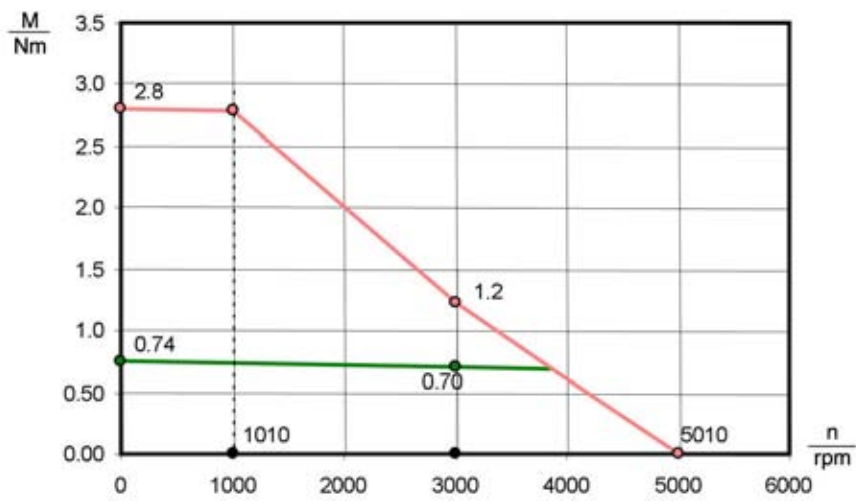

Area for your notes:

Encoders for servomotors

Ordering option	Encoder drawing		Compatible with				Encoder characteristic		System characteristic		
	Description	sin/cos periods/revolution	LST 037	LSx-050	LSH-074 to LSH-127	LST 074 to LST-220	Typical absolute accuracy of the encoder (encoder manufacturer's data sheet)	Typical repetition accuracy of the encoder (encoder manufacturer's data sheet)	ServoOne positional resolution for positioning speed control	c-line positional resolution for positioning control	c-line positional resolution for speed control
1R	Resolver with 1 pole pairs	1	X	X	X	X	+/-10'	+/- 1'	14 bit +/-1'	14 bit +/-1'	14 bit +/-1'
3R	Resolver with 3 pole pairs	3	X	X		X	+/-5'	+/- 1'	3x14 bit +/- 0.3'	3x14 bit +/- 0.3'	3x14 bit +/- 0.3'
5R	Resolver with 5 pole pairs	5			X		+/-5'	+/- 1'	5x14bit +/- 0.2'	5x14bit +/- 0.2'	5x14bit +/- 0.2'
G3	Multi-turn absolute value encoder EQN 1325 SSI	2048			X	X	+/- 20"	+/- 6"	25bit +/- 0.04"	16 bit (CDD)	25bit +/- 0.04"
G5	Single-turn absolute value encoder ECN 1313 SSI	2048			X	X	+/- 20"	+/- 6"	25bit +/- 0.04"	16 bit (CDD)	25bit +/- 0.04"
G6.1S ¹⁾	Single-turn absolute value encoder SRS 50	1024			X	X	+/-45"	+/- 7"	24bit +/- 0.08"	16 bit (CDD)	24bit +/- 0.08"
G6.1M ¹⁾	Multi-turn absolute value encoder SRM 50	1024			X	X	+/-45"	+/- 7"	24bit +/- 0.08"	16 bit (CDD)	24bit +/- 0.08"
G6.2S ¹⁾	Single-turn absolute value encoder SKS 36	128		X	X	X	+/- 80"	+/- 40"	21bit +/- 0.6"	16 bit (CDD)	21bit +/- 0.6"
G6.2M ¹⁾	Multi-turn absolute value encoder SKM 36	128		X	X	X	+/- 80"	+/- 40"	21bit +/- 0.6"	16 bit (CDD)	21bit +/- 0.6"
G12.1S ¹⁾	Single-turn absolute value encoder ECN 1313 Endat 2.1	2048			X	X	+/- 20"	+/- 6"	25bit +/- 0.04"	16 bit (CDD)	25bit +/- 0.04"
G12.1M ¹⁾	Multi-turn absolute value encoder EQN 1325 Endat 2.1	2048			X	X	+/- 20"	+/- 6"	25bit +/- 0.04"	16 bit (CDD)	25bit +/- 0.04"
G12.2S ¹⁾	Single-turn absolute value encoder ECN 1113 Endat 2.1	512			X	X	+/-60"	+/- 25"	23bit +/-0.16"	16 bit (CDD)	23bit +/-0.16"
G12.2M ¹⁾	Multi-turn absolute value encoder EQN 1125 Endat 2.1	512			X	X	+/-60"	+/- 25"	23bit +/-0.16"	16 bit (CDD)	23bit +/-0.16"

¹⁾ not for use on CDE3000 or CDF3000

Area for your notes:

Accessories for servomotors

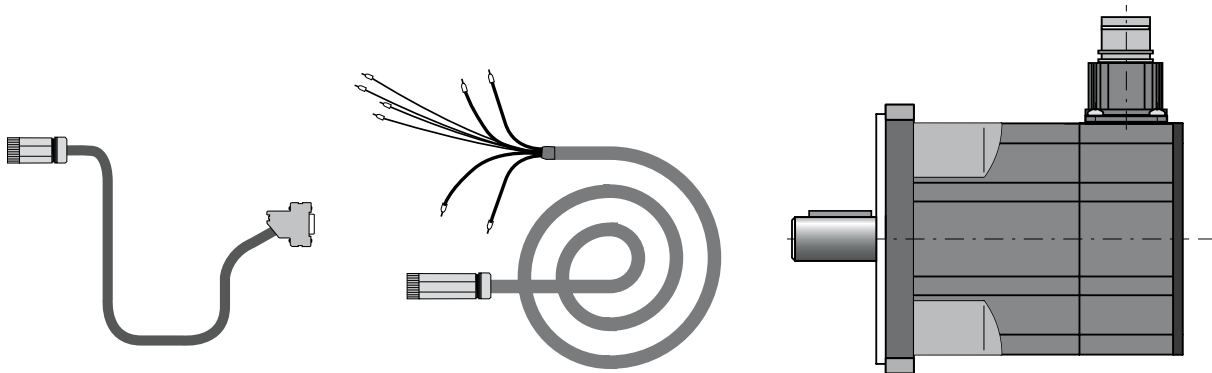

Contents	Type	Page
Encoder cable	KRY2-KSxxx	6-2
	KGS2-KSxxx	
	KGH2-KSxxx	
	KGH3-KSxxx	
	KRY2-CDF	
Motor cable	KM2-KSxxx	6-3
	KM3-KSxxx	

Ready made-up encoder cables



	K	RY2	-	KS	005
Encoder cable					
Ready made-up cable					
Resolver cable		RY2			
Encoder cable SSI, G3, G5, EnDat 2.1, G12.x		GS2			
Encoder cable Hiperface (G6.x) CDD		GH2			
Encoder cable Hiperface (G6.x) SO		GH3			
Encoder system					
Trailing cable carrier-compatible				KS	
Version					
Length 2 m					002
Length 3 m					003
Length 5 m					005
Length 8 m					008
Length 10 m					010
Length 15 m					015
Length 20 m					020
Cable length					
Encoder cable KRY2-KS-005					
					Order code

Technical data

	KRY2-KSxxx	KGS2-KSxxx	KGH2-KSxxx	KGH3-KSxxx	KRY2-CDF-KSxxx
Controller type	CDD/CDE/SO	CDD/CDE/SO	CDD	SO	CDF
Motors with encoder system	Resolver	G3, G5 (single- or multi-turn encoder with SSI/Endat)	G6, G6.x (single- or multi-turn encoder with Hiperface interface)	G6, G6.x (single- or multi-turn encoder with Hiperface interface)	Resolver
Controller-side pin assignment (sub-D plug)	1 = S2 2 = S4 3 = S1 4 = n.c. 5 = PTC+ 6 = R1 7 = R2 8 = S3 9 = PTC-	1 = A- 2 = A+ 3 = VCC (+5 V) 4 = DATA+ 5 = DATA- 6 = B- 8 = GND 11 = B+ 12 = VCC (Sense) 13 = GND (Sense) 14 = CLK+ 15 = CLK- 7, 9, 10 = n.c.	1 = REFCOS 2 = +COS 4 = DATA+ RS485 5 = DATA- RS485 6 = REFSIN 7 = US 7-12 V 8 = GND 11 = +SIN 3, 9, 10, 12, 13, 14, 15 = n.c.	1 = REFCOS 2 = +COS 3 = Us 7 - 12 V 6 = REFSIN 7 = bridge to PIN 12) 8 = GND 11 = +SIN 12 = bridge to PIN 7) 14 = data+ RS485 15 = data- RS485 4, 5, 9, 10, 13 = n.c.	1 = SIN- (S4) 2 = SIN+ (S2) 6 = COS- (S3) 7 = REF- (R2) 9 = PTC- 10 = PTC+ 11 = COS+ (S1) 12 = REF+ (R1) 3, 4, 5, 8, 13, 14, 15 = n.c
Trailing cable carrier-compatible	Yes				
Minimum bend radius:	for fixed installation: - for flexible use: 90 mm	40 mm 100 mm	- 90 mm	- 90 mm	- 90 mm
Temperature range:	for fixed installation: -40 ... +85 °C for flexible use: -40 ... +85 °C	-35 ... +80 °C -35 ... +80 °C	-40 ... +85 °C	-40 ... +85 °C	-40 ... +85 °C
Cable diameter approx.	8.8 mm	8.8 mm	8.8 mm	8.8 mm	8.8 mm
Material of outer sheath					
Resistant to	oil, hydrolysis and microbial attack (VDE 0472)				
Approvals	UL style 20233, 80 °C - 300 V, CSA-C22.2N.210-M90, 75 °C - 300 V FT1				

Ready made-up motor cables



Motor cable KMx-KS-005

	KMx	-	KS	005	-
Encoder cable					
Ready made-up cable CDD/CDE	2				
SO	3				
Trailing cable carrier-compatible			KS		
Version					
Length 2 m				002	
Length 3 m				003	
Length 5 m				005	
Length 8 m				008	
Length 10 m				010	
Length 15 m				015	
Length 20 m				020	
Cable length					
Order code					
Motor cable up to I _o = 16 A					-
Motor cable up to I _o = 24 A					24 A
Motor cable up to I _o = 63 A (only LSx-220)					63 A

Technical data

	KM2/3-KSxxx	KM2/3-KSxxx-25	KM2/3-KSxxx-100
Motor type	Motors up to I _o = 16 A with plug connection for power cable	Motors up to I _o = 24 A with plug connection for power cable	Motors up to I _o = 63 A with plug connection for power cable
Minimum bending radius:	for fixed installation: 60 mm for flexible use: 120 mm	75 mm 150 mm	110 mm 220 mm
Temperature range	for fixed installation: -50 ... +90 °C for flexible use: -50 ... +90 °C	-50 ... +90 °C -50 ... +90 °C	-50 ... +90 °C -50 ... +90 °C
Cable diameter approx.	Ø 12 mm	Ø 15 mm	Ø 22 mm
Cable cross-section	4G1,5 + 2 x 2 x 0.75 mm ²	4G2,5 + 2 x 2 x 1 mm ²	4G10 + 2 x 1.5 mm ² + 2 x 1 mm ²
Material of outer sheath	PUR	PUR	PUR
Resistant to	oil, hydrolysis and microbial attack (VDE 0472), UL 20233, 80 °C - 300 V	oil, hydrolysis and microbial attack (VDE 0472), UL 20233, 80 °C - 300 V	oil, hydrolysis and microbial attack (VDE 0472), UL 20233, 80 °C - 300 V
Arrangement of cores	U = 1 V = 2 W = 3 earth = ye/gn PTC = 5 PTC = 6 brake + = 7 brake - = 8	U = 1 V = 2 W = 3 earth = ye/gn PTC = 5 PTC = 6 brake + = 7 brake - = 8	U = 1 V = 2 W = 3 earth = ye/gn PTC = 5 PTC = 6 brake + = 7 brake - = 8
Approval	UL style 20234, 80 °C - 1000 V CSA-C22.2 N.210-M90, 80 °C - 1000V FT1	UL style 20234, 80 °C - 1000 V CSA-C22.2 N.210-M90, 80 °C - 1000V FT1	UL style 20234, 80 °C - 1000 V CSA-C22.2 N.210-M90, 80 °C - 1000V FT1



Note. Cores 5 and 6 (PTC) are needed only for motors with optical encoders (G3, G5, G6.x, G12.x). For LSx motors with resolvers, the PTC monitoring uses the resolver cable.

Area for your notes:

Appendix

Holding brake



The backlash-free, permanent-field single-disc holding brake works on the closed circuit principle, meaning that current needs to be applied to the brake to release it.

For optimum holding torque and least possible torsional play the holding brake is mounted directly behind the flange (A-end) on all LSx motors.

The holding brake is always activated and deactivated at standstill. When the holding brake is deployed as an emergency stop brake, you need to take account of the maximum permissible frictional work (WR).

An LSH servomotor with holding brake is identifiable by the name plate.

Example: LSH-074-1-30-560/T1, B



When the holding brake is deployed as an emergency stop brake, the braking torque may be substantially lower than the holding torque.

Holding brake response times

Triggered from the AC side:

Is performed before the rectifier on the AC side. Here the magnetic field decays slowly and the brake releases gently with a delay (switch-off time $t_2 \approx$).

Triggered from the DC side:

Is performed between the rectifier and the solenoid coil, thus achieving an extremely short time-lag. For all drives that require precise braking, in particular for lifting gear, DC side triggering of the brake is absolutely essential (switch-off time $t_2 =$).

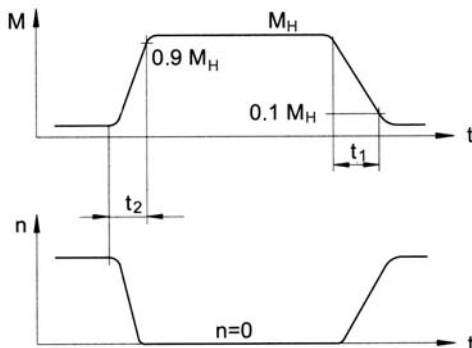

M	Braking torque	t	Time
M_H	Holding torque of the spring pressure brake	t_1	Activation time
N	Speed	t_2	Deactivation time

Technical data

Size	t_1 [ms]	t_2 [ms]	M_H [Nm]	I_N [A] bei 24 V	U_N [V]	n_{max} [rpm]	m [kg]	W_R [10 ⁶ Ws]	J_B [kgcm ²]
LST-037	6	10	0.4	0.33	24 V ± 10 %	10,000	0.075	0.20	0.013
LScx-050	6	25	2.0	0.46		10,000	0.15	0.41	0.07
LSx - 074	7	35	4.5	0.5		10,000	0.3	0.58	0.18
LSx - 097	7	40	9.0	0.75		10,000	0.82	0.89	0.54
LSx - 127	10	50	18.0	1.0		10,000	1.8	1.29	1.66
LST-158	22	90	36	1.1		10,000	2.85	2.90	5.56
LST-190	22	90	36	1.1		8,000	3.25	2.9	6.2
LST-220	65	105	145	2.1		8,000	9.5	13	56

M_H holding torque (break-away torque)	m mass (weight)
I_N exciter current at 20° C for release	W_R permissible frictional work up to 0.1 mm wear (for emergency stop)
U_N for release	J_B moment of inertia of the holding brake
n_{max} maximum speed (unbraked)	



Note: The data specified above for m and J_B are purely braking data, without taking into account the necessary additional mass of the motor shaft.



We reserve the right to make technical changes.

LUST

Lust Antriebstechnik GmbH
Gewebestr. 5-9
35633 Lahnau
GERMANY
Tel. +49 (0) 64 41/9 66 -0
Fax +49 (0) 64 41/9 66 -1 37

Heinrich-Hertz-Str. 18
59423 Unna
GERMANY
Tel. +49 (0) 23 03/7 79 -0
Fax +49 (0) 23 03/7 79 -3 97

info@lust-tec.de
www.lust-tec.de