

CLEANING



- | | | | |
|-----|--|-----|--|
| 352 | Pool cleaner accessories | 356 | Manual pool cleaners - Classic Range |
| 352 | Suction automatic pool cleaners | 360 | Net'n'Clean Integrated Cleaning System |
| 353 | Manual pool cleaners - Blue Line Range | 362 | Hoses |
| 355 | Manual pool cleaners - Shark Range | | |



- | | | | |
|-----|----------------------------|-----|---------------------------|
| 364 | ELECTRICAL CLEANERS | 394 | HYDRAULIC CLEANERS |
| 370 | Tornax | | |
| 373 | Cyclonx™ | | |
| 377 | Voyager™ | | |
| 383 | Vortex™ 4WD range | | |
| 386 | Alpha iQ™ PRO | | |



- | | | | |
|-----|----------------------------|--|--|
| 401 | PRESSURE CLEANERS | | |
| 406 | Tailsweep Pro | | |
| 407 | Booster Pump & Control box | | |



Pump caddy



for stand-alone pool cleaners

DESCRIPTION

Made of anodized aluminium tube and a 460 mm x 370 mm plastic platform. Face plate in AISI-304 stainless steel.

Code	Standard Pack	Standard weight in kg	Standard volume in m ³
04648	1	8.06	0.12

SUCTION AUTOMATIC POOL CLEANERS

Splasher



DESCRIPTION

Splasher is an hydraulic suction cleaner. It's using the pool filtration system to work and collect the debris in the pump pre-filter.

It is simply connected to the skimmer vacuum plate and works at the same time than the pool filtration.

Its membrane system ensures an optimum and quieter performance.

- Cleaning areas: floor and walls.
- Pool floors types: flat or gentle slopes.
- Pool size: up to 9m length.
- Filter pump minimum required pressure: ½ HP.
- Included in pack : 9,6m hose.

	Code	Standard Pack	Standard weight in kg	Standard volume in m ³
Splasher suction cleaner	66281	1	5.6	0.05

Mamba



DESCRIPTION

Mamba is an hydraulic suction cleaner. It's using the pool filtration system to work and collect the debris in the pump pre-filter.

It is simply connected to the skimmer vacuum plate and works at the same time than the pool filtration.

The Mamba's dual suction design ensures the pump and filter are never starved of water. The adjustable bypass valve allows for operation from small to large capacity filtration pumps.

- Cleaning areas: floor and walls.
- Pool floors types: flat or gentle slopes.
- Pool size: up to 9m length.
- Filter pump minimum required pressure: ½ HP.
- Included in pack : 12 x 80 cm hose sections, flow regulator, universal adapter.

	Code	Standard Pack	Standard weight in kg	Standard volume in m ³
Mamba suction cleaner	60092	1	7	0.061

Blue Line

manual suction cleaner - wing-nut fastening



69661



69673



69663



69664

	Code	Standard Pack	Standard weight in kg	Standard volume in m ³
1 1/2" 350 flexible pool cleaner	69661	6	6.6	0.053
1 1/2" 350 aluminium pool cleaner	69673	6	-	-
Triangular pool cleaner	69663	6	-	-
Oval pool cleaner	69664	6	-	-



69656



69658



69669

Blue Line

wall brush - wing-nut fastening



	Code	Standard Pack	Standard weight in kg	Standard volume in m ³
Adjustable handle wall brush (48 cm)	69656	12	2.5	0.04
Fixed handle wall brush (50 cm)	69658	12	3.9	0.04
Multifunction manual brush	69669	24	-	-

Blue Line leaf skimmer - wing-nut fastening



69665



69666

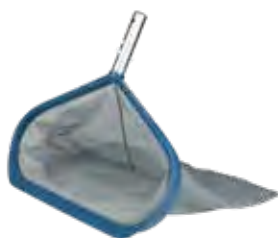

69667

	Code	Standard Pack	Standard weight in kg	Standard volume in m ³
Plastic flat leaf skimmer	69665	12	-	-
Plastic net leaf skimmer fixed handle	69666	12	-	-
Aluminium net leaf skimmer	69667	12	-	-



69659 - 69660

Blue Line handles - wing-nut fastening



	Code	Standard Pack	Standard weight in kg	Standard volume in m ³
1.8-3.6 m easy regulation aluminium handle	69659	12	-	-
2.4-4.8 m easy regulation aluminium handle	69660	12	-	-



Blue Line cleaning material wall bracket



	Code	Standard Pack	Standard weight in kg	Standard volume in m ³
Cleaning material wall bracket	69662	6	-	-



Blue Line floating dispenser



	Code	Standard Pack	Standard weight in kg	Standard volume in m ³
Floating dispenser for 200g tablets	69668	12	-	-

Shark pool cleaner - wing-nut or wishbone fixing



	Code	Standard Pack	Standard weight in kg	Standard volume in m ³
Shark Flexo pool cleaner	36618	6	9.9	0.04
Shark Oval pool cleaner	40997	5	6.4	0.04
Shark Triangular pool cleaner	36619	4	5.2	0.04



36618



40997



36619

Shark brushes - wing-nut or wishbone fixing



	Code	Standard Pack	Standard weight in kg	Standard volume in m ³
Shark special bottom curved brush	36615	10	3.7	0.04
Shark bottom/walls curved brush	36616	15	4.2	0.04
Shark corner suction brush	36617	12	2.4	0.04



36615



36616



36617



36613

36614

Shark leaf skimmers - wing-nut or wishbone fixing



	Code	Standard Pack	Standard weight in kg	Standard volume in m ³
Shark water surface leaf skimmer	36613	15	6.2	0.14
Shark deep water leaf skimmer	36614	15	6.5	0.14



38422 - 38423

Shark telescopic pole - wing-nut or wishbone fixing



	Code	Standard Pack	Standard weight in kg	Standard volume in m ³
Shark 1.8 - 3.6 m telescopic pole	38422	10	11.7	0.05
Shark 2.4 - 4.8 m telescopic pole	38423	10	14.4	0.06

Shark floating dispenser for 5 tablets



	Code	Standard Pack	Standard weight in kg	Standard volume in m ³
Floating dispenser for 5 tablets 200 g Shark	36620	12	6.6	0.14



Shark submersible analogue thermometer



	Code	Standard Pack	Standard weight in kg	Standard volume in m ³
Shark submersible analogue thermometer	36622	10	2.8	0.04



Classic pool cleaner - wing-nut fastening



01355 - 01356

	Code	Standard Pack	Standard weight in kg	Standard volume in m ³
Classic extruded aluminium pool cleaner 1 1/2" connection 350 mm	01355	4	10.2	0.04
Classic extruded aluminium pool cleaner 2" connection 450 mm	01356	4	12.2	0.06

Classic Flexo pool cleaner



	Code	Standard Pack	Standard weight in kg	Standard volume in m ³
Wishbone fixing	01351	4	7.2	0.04
Wing-nut fixing	01352	4	7.2	0.04

Classic brushes - wing-nut fastening



01405



01407



09456

Straight brush

	Code	Standard Pack	Standard weight in kg	Standard volume in m ³
Classic PP bristle 330 mm	01405	20	2.8	0.04
Classic S.S. bristle 165 mm	01407	20	9.0	0.018
Classic PP bristle 180 mm	09456	14	6.1	0.177

Classic brush holder - wing-nut fastening



	Code	Standard Pack	Standard weight in kg	Standard volume in m ³
Classic water surface leaf skimmer with handle incorporated	01400	12	5	0.18

Classic fixed handle - wing-nut fastening



	Code	Standard Pack	Standard weight in kg	Standard volume in m ³
Classic fixed handle 2.5 m	01365	12	10.2	0.06

Classic pool cleaner - wishbone fixing



01353-01354-08661

	Code	Standard Pack	Standard weight in kg	Standard volume in m ³
Extruded aluminium pool cleaner				
1 1/2" connection 350 mm	01353	4	11.8	0.04
2" connection 450 mm	01354	4	15.5	0.06
1 1/2" connection 450 mm	08661	4	15.5	0.06

Classic



public pool aluminium pool cleaner - wishbone fixing



16601

01357



01358

	Code	Standard Pack	Standard weight in kg	Standard volume in m ³
Length: 800 mm				
Drag with cable (00210 not included)	01357	1	13.0	0.03
With nozzle	16601	1	13.0	0.03
Length: 450 mm				
With nozzle 1 1/2" - 2" connection	01358	4	13.6	0.05

Classic brushes - wishbone fixing



01406



01404

	Code	Standard Pack	Standard weight in kg	Standard volume in m ³
PP bristle 330mm straight brush	01406	20	2.8	0.04
Bottom/walls curved brush	01404	20	4	0.05
Floating line brush	11789	20	3.8	0.03

Classic leaf skimmers



01398



01396

	Code	Standard Pack	Standard weight in kg	Standard volume in m ³
Wishbone fixing				
Water surface leaf skimmer	01398	20	4.2	0.12
Deep water leaf skimmer	01396	20	4.3	0.12
Wing-nut fixing				
Water surface leaf skimmer	01399	20	4.3	0.12
Deep water leaf skimmer	01397	20	4.4	0.12



Classic fixed handle - wishbone fixing



	Code	Standard Pack	Standard weight in kg	Standard volume in m ³
Fixed handle 2.5 m	01364	20	11.4	0.06



Shark telescopic pole - wing-nut or wishbone fixing



	Code	Standard Pack	Standard weight in kg	Standard volume in m ³
Classic 1.8 - 3.6 m telescopic pole	01359	12	13.4	0.05
Classic 2.4 - 4.8 m telescopic pole	01360	12	16.2	0.06

Classic reinforced telescopic pole - Public pools



DESCRIPTION

Reinforced telescopic pole, aluminium



	Code	Standard Pack	Standard weight in kg	Standard volume in m ³
2.5 - 5 m	01361	5	16.0	0.04
3.75 - 7.5 m	15838	1	6.0	0.01
5 - 10 m	01362	1	6.5	0.02
6.5 - 13 m	01363	1	8.4	0.02

Hose adapter



DESCRIPTION

For connecting wing nut assembly to clip hose or clip assembly to wing nut hose.

	Code	Standard Pack	Standard weight in kg	Standard volume in m ³
Adapts the wishbone handle connection to wing-nut connection	08465	35	2.55	0.01
Adapts the reinforced pole connection to wing-nut connection	17937	38	2.66	0.01

Hose adapter



DESCRIPTION

For connecting wing nut assembly to clip hose or clip assembly to wing nut hose.

	Code	Standard Pack	Standard weight in kg	Standard volume in m ³
Adapts the connection hose clip to wing nuts	14592	48	3.36	0.01

Thermometers



DESCRIPTION

Celsius & Fahrenheit scale.

	Code	Standard Pack	Standard weight in kg	Standard volume in m ³
	20594	20	2.1	0.032

Integrated cleaning system

- The Net'N'Clean is an efficient cleaning system, consisting of a six outlet distributor valve that receives clean water from the filter and distributes it sequentially to a series of nozzles installed on the pool floor.
- This type of distribution from the bottom keeps the particles in suspension so they are collected by the skimmer and main drain and retained by the filter. It helps improve the use and efficiency of chemical products injected in the return piping and reduces heating costs by returning hot water along the bottom.

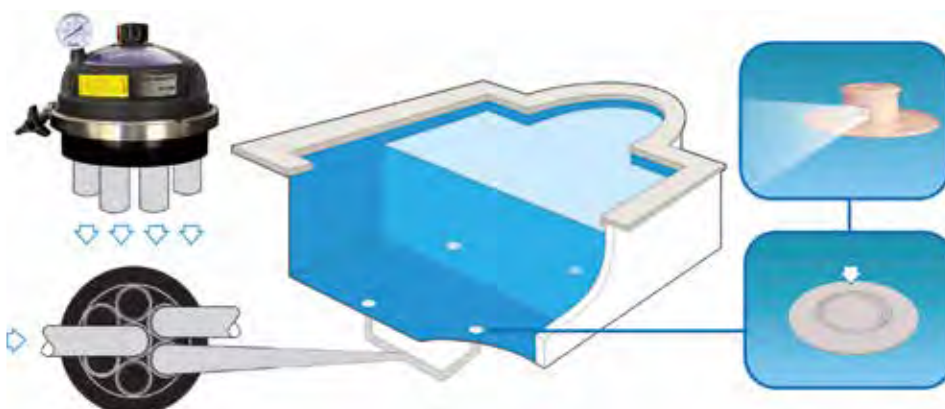

CLEANING



Net'n'Clean distributor valve Ø 50 mm



DESCRIPTION

Six way distribution valve. This valve is part of the Net'n'Clean cleaning system which is integrated in the pool floor. It distributes water sequentially through its various branches. Made of plastic and AISI 316L it has high resistance to salt water. Maximum working pressure: 1.4 bars. Maximum flow: 15 m³/h. Connections: 7 x Ø 50 mm. 2 pop-up nozzles for branch recommended.

	Code	Standard Pack	Standard weight in kg	Standard volume in m ³
Net'n'Clean distributor valve: European model	21257	1	1.7	0.015



Net'N'Clean distributor valve Ø 63 mm



DESCRIPTION

Distributor valve optimized for greater hydraulic performance. Maximum working pressure of 1.5 bars. Maximum flow of 25 m³/h. Connections: 7 x Ø 63 mm or 7 x Ø 75 mm. From 2 to 5 nozzles per branch.

	Code	Standard Pack	Standard weight in kg	Standard volume in m ³
Net'N'Clean distributor valve Ø 63 mm	35079	1	5.6	0.031

Net'N'Clean reducing wall conduit for nozzles

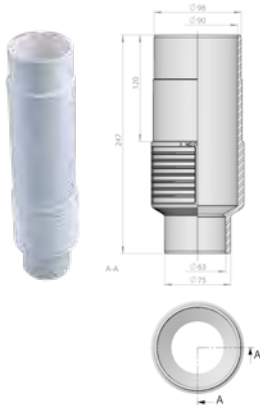

DESCRIPTION

Reducing conduit to install concrete Net'N'Clean nozzles (26985). Made in white PVC. Ø 50 mm inside & Ø 63 mm outside connections.

	Code	Standard Pack	Standard weight in kg	Standard volume in m ³
Reducing wall conduit for nozzles	21248	12	7.3	0.032

Ø 90 mm wall conduit



DESCRIPTION

PVC wall conduit. Cutting area of 120 mm for fitting it to the pool wall or floor. Ø 63 or Ø 75 connection, as required.

	Code	Standard Pack	Standard weight in kg	Standard volume in m ³
Ø 90/Ø 63-Ø 75 mm wall conduit	43590	9	7.3	0.033

For inlets:

Net'N'Clean: 43584

BCN 03: 43586 - 43587 - 43588 - 43589

Return inlet/suction nozzle for high flow rates: 41518 - 41519 - 41520 - 41521

Net'N'Clean nozzles



DESCRIPTION

Range of Net'N'Clean nozzles with four different outlets. S4 is recommended for pool floor and S1 or S2 for steps. Designed for concrete pools with glass tiling, liner pools and polyester pools. For in-ground pools, both adjustable and fixed nozzles are available, and for liner pools there are self-tapping nozzles or nozzles with metal inserts.

	Code	Standard Pack	Standard weight in kg	Standard volume in m ³
Nozzles				
For concrete pools:				
With swivel joint	26985	12	4.14	0.02
Fixed	26986	12	3.78	0.02
For polyester pools:				
Fixed	21209	12	4.14	0.02
For liner pools:				
Fixed, with PN10 metal insert	28500	12	5.05	0.034
Adjustable, with INSERTS	43584	12	5.64	0.033
Bodies				
For concrete pools:				
With swivel joint	65230	12	4.44	0.02
Fixed	65231	12	4.44	0.02
For polyester pools:				
Fixed	65232	12	4.44	0.02

Inner assembly kit



DESCRIPTION

Colours can be selected with the minimum number of parts. Existing pools can be renewed without any effort.

	Code	Standard Pack	Standard weight in kg	Standard volume in m ³
Inner assembly kit				
White	65234	12	4.4	0.031
Beige	65234CL090	12	4.4	0.031
Light grey	65234CL129	12	4.4	0.031
Anthracite grey	65234CL144	12	4.4	0.031

Polyester

Concrete

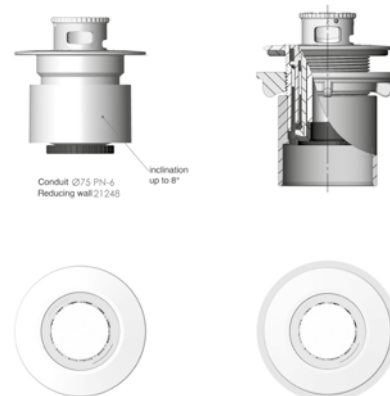

HOSES

Hose connectors



	Code	Standard Pack	Standard weight in kg	Standard volume in m ³
Ø 38 mm for connections to inlets 16328, 16329, 16330, 21644, 21645, in white ABS	05684	12	1.0	0.003
Ø 50 mm connections to inlets 00315, grey PP	01392	12	1.0	0.006

Hose fitting



DESCRIPTION

White ABS plastic.

	Code	Standard Pack	Standard weight in kg	Standard volume in m ³
For Ø 38 mm hose, male thread 1½"	01393	12	1.0	0.006

HOSES

Hose cuffs



	Code	Standard Pack	Standard weight in kg	Standard volume in m ³
Made in flexible blue PVC				
For Ø 38 mm (01372) hose Only for vac inlets 24415	07958	12	2.0	0.003
For Ø 38 mm hose (01372)	01385	12	2.0	0.003
For Ø 50 mm hose (01373)	01386	12	3.0	0.010
Made in flexible white PVC				
For Ø 38 mm hose (01374-01375 01376-01377-01378)	01387	12	2.0	0.030
For Ø 50 mm hose (01379)	01388	12	3.0	0.010



Floating suction hose



DESCRIPTION

Transparent blue Polyethylene hose.

	Code	Standard Pack	Standard weight in kg	Standard volume in m ³
Ø 38 mm (1½")	01372	30 m	8.0	0.108
Ø 50 mm (2")	01373	30 m	14.0	0.192



Floating suction hose



DESCRIPTION

Made of blue polyethylene. Includes terminals, except in the 30-m hose (01374, 01379).

	Code	Standard Pack	Standard weight in kg	Standard volume in m ³
Ø 38 mm (1½")				
30 m	01374	1	12.0	0.192
15 m	01375	1	5.6	0.192
12 m	01376	1	4.5	0.192
10 m	01377	1	3.0	0.192
8 m	01378	1	3.0	0.192
Ø 50 mm (2")				
30 m	01379	1	15.0	0.240



Hose roller



DESCRIPTION

For hoses of up to 15 metres.

	Code	Standard Pack	Standard weight in kg	Standard volume in m ³
Hose roller	66042	1	2.4	0.05

3 TECHNOLOGIES FOR SWIMMING POOL CLEANING

To clean a pool as well as possible, multiple parameters are considered in **the choice of cleaning equipment**: shape and lining of the pool, standard of cleaning, volume to be covered, etc.

High technology Zodiac® cleaners match the different features of a pool, the cleaning time and every budget.

3 types of technologies are currently available: electric cleaning, hydraulic cleaning and pressure cleaning.

> ZODIAC® ELECTRIC ROBOTIC CLEANERS:

A HIGH-PERFORMANCE, STAND-ALONE SYSTEM

Separate from the filtration system and simply connected to the mains power, they are Plug&Play and **stand-alone equipment**.

With no action required and **programmable** (cleaning time, area to be covered, etc.), they reach every corner of the pool, climb the walls, clean the water line and collect impurities in their own filter basket.

There are different models for all types of pools.



> ZODIAC® HYDRAULIC ROBOTIC CLEANERS:

A SIMPLE AND AFFORDABLE SOLUTION

Hydraulic robotic cleaners can be easily installed in the pool filtration system. In fact, they work on the energy produced by your pump.

Vacuum cleaners capture debris by suction and accumulate it in the pump pre-filter.

More affordable than electric cleaners, hydraulic cleaners are connected to a pool vacuum point or a skimmer and are **particularly suitable for the smallest pools** (with a flat floor or gentle slope and above-ground pools).

> AUTOMATIC POLARIS® CLEANERS:

THE POWER OF A HIGH-PRESSURE CLEAN

These cleaners **use the swimming pool's filtration pump as a power source** for even more efficient and precise high-pressure cleaning. Instead of being connected to the suction, pressure cleaners are connected to the pool water return, using the vacuum point converted to discharge. In this way, the pool skimmers remain active and maintain full surface filtration capacity.

Pressure cleaners work with a booster pump and have a canister that collects debris sucked in, preventing the pump pre-filter from becoming blocked.



To optimise the efficiency of these accessories, it is essential to **ensure they are compatible with the pool lining**, filtration equipment, environment, etc.

ELECTRIC ROBOT CLEANERS

A stand-alone and efficient solution

The electric robots combine **the best of Zodiac® technology.**

Thanks to the embedded cyclone suction, a patented Zodiac® technology, **the cleaning performance is maintained throughout the cleaning cycle.** They even capture the finest debris without filter clogging.

Separate from the filtration system, these Plug&Play devices trap debris in their own filter basket, making them stand-alone.



> TORNAX PRO, EFFICIENCY PURE & SIMPLE

The Tornax robotic cleaner guarantees **efficient cleaning** of your pool, completely autonomously, thanks to its smart movement and its rotating brush, which removes debris before collecting it. Tornax is the **lightest** (5.5 kg) of all the Zodiac® robotic cleaners. It is feather-light, meaning it is quick, easy and **effortless** to operate. Tornax is designed not only to be easy to use but also easy to maintain, as the filter can be accessed from the top so it can be rinsed without touching the debris.



> CYCLONX™ PRO, CONCENTRATED TECHNOLOGY

Robotic cleaners in the CyclonX™ PRO range provide optimum cleaning of the pool, thanks to several pre-programmed cycles, a **Deep Clean** cycle to clean the pool floor and a one-hour **Quick Clean** program. Thanks to their large capacity filter (up to 3.7 L) and their wide suction inlets, all debris is collected. The filter can be easily cleaned using the **Push'n'Go™** function, a patented Zodiac® innovation that helps raise the filter basket handle with the push of a button.



> VOYAGER™, FULL ON AGILITY

With its patented cyclonic suction, VOYAGER™ range adapts to all pools and all coatings. Thanks to **embedded sensors** such as gyroscope or accelerometer, the robotic cleaner offers **excellent coverage of each pool.** Also remotely accessible via the iAqualink™ application. Its helical brushes, its **double filtration canister** (60 and 150 microns) and its large suction inlet of 23cm allow a thorough cleaning of all areas of the pool.



> VORTEX™ PRO 4WD, ULTIMATE POWER IN A 4 X 4 VERSION

Robotic cleaners from the Vortex™ PRO 4WD range are equipped with Zodiac® patented **extra-powerful and long-lasting suction.** Equipped with **4-wheel drive**, these robotic cleaners are truly all-terrain: they adapt to all kinds of surfaces, perfectly grip the walls and get over obstacles more easily. Most of Vortex™ PRO 4WD robotic cleaners also come with **Lift System** technology, so they are lighter when being removed from water (20% less effort).



> ALPHA iQ™, ULTRA-EFFICIENCY COMBINED WITH INTELLIGENCE

With its Sensor Nav System™, the ALPHA iQ™ range identifies the configuration of your pool **to optimise movements** and cleaning time. The patented cyclone suction guarantees **extremely powerful and long-lasting suction.** Thanks to its patented **Lift System**, ALPHA iQ™ is lighter when removing it from the water. Monitor cleaning progress at any time through the **intuitive interface** of the iAquaLink™ application. ALPHA iQ™ is **upgradeable** thanks to possible optimisations and automatic remote updates.



CYCLONIC SUCTION

Patented technology for powerful cleaning

> HOW DOES IT WORK?

Thanks to its unique design, Vortex cleaners feature **Cyclonic Suction** : the flow is **keeping debris in suspension inside the filter** and allows a longer lasting suction while **limiting the clogging**.

Robotic cleaners equipped with cyclonic suction can be found here:
**RE 4300, RE 4200, RE 4400 iQ, RE 4600 iQ, RV 5300, RV 5380,
 RA 6300 iQ, RA 6500 iQ, RA 6700 iQ, RA 6800 iQ and RA 6900 iQ**



LIFT SYSTEM

Patented innovation for easier removal from the water

> 20% LESS EFFORT

The robotic cleaner positions itself on the chosen wall and cleans right up to the water line. Then a powerful waterjet propels it from the water: **which means you can remove the robot from the water with just 20% of the effort**.

Robotic cleaners equipped with Lift system:
**RE 4600 iQ, RV 5380, RA 6300 iQ, RA 6500 iQ, RA 6700 iQ,
 RA 6800 iQ and RA 6900 iQ**



SENSOR NAV SYSTEM™

Smart navigation system for efficient and customized cleaning

> PERSONALISED CLEANING OF EACH POOL

Sensor Nav System™ gathers different embedded features which enable **the robotic cleaners to learn all about each pool and to adapt its cleaning** in the smartest way.

- Recognition and analysis of the pool dimensions and shape to provide an optimized navigation pattern and cleaning time for each pool.
- Focusing on common dirty areas such as bottom of the walls or flat areas of the pool

Robotic cleaners equipped with Smart Nav system™: **RA 6300 iQ, RA 6500 iQ,
 RA 6700 iQ, RA 6800 iQ and RA 6900 iQ**

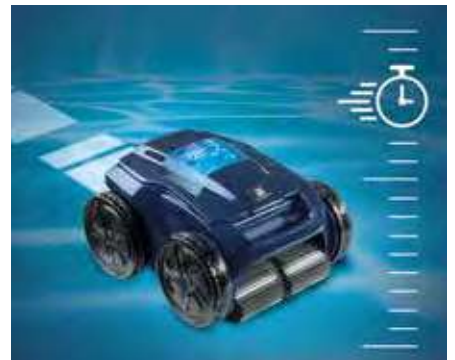



SWIVEL

Avoid cable tangling

> HOW DOES IT WORK?

Automatic swivel system prevents cable tangling during cleaner operation in the pool.

The cleaner efficiency is optimized and the cable storage is easier.

Robots equipped with Swivel: **RV 5380, RV 5600, RA 6300 iQ, RA 6500 iQ, RA 6700 iQ, RA 6800 iQ and RA 6900 iQ**



4-WHEEL DRIVE (4WD)

Effective cleaning of all surfaces

> GETTING OVER OBSTACLES MORE EASILY

Equipped with **4-wheel drive**, robots from the **Vortex™ PRO 4WD** and **ALPHA iQ™** ranges adapt to all situations.

> OPTIMAL COVERAGE AND PERFECT GRIP

Thanks to their excellent grip, robots from the **Vortex™ PRO 4WD** and **ALPHA iQ™** ranges get into the tiniest corners of the pool and clean **all kinds of surface**. The robots ensure **the pool is cleaned perfectly**.

Robotic cleaners equipped with 4 Wheel-drive:
RV 5300, RV 5380, RA 6300 iQ, RA 6500 iQ, RA 6700 iQ, RA 6800 iQ and RA 6900 iQ

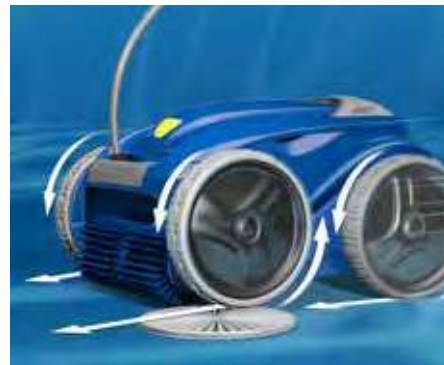

DUAL STAGE FILTRATION

Finer filtration and long lasting suction

> 2 FILTERS FOR LONG LASTING SUCTION AND FINER DEBRIS PICK UP

These 2 combined filters offer a larger mesh surface that a standard filter which allows to postpone the clogging effects. This unique design also allows the ability to use the larger mesh filter alone, which can be very useful at the beginning of the season

> HOW DOES IT WORK?

2 imbricated filters : the dirty water flows through a coarse layer first (150µ) and a finer one after (60µ). The coarse filter will retain the larger debris and the finer one will then allow a finer filtration.

Robotic cleaners equipped with Dual-stage filtration:
RE 4300, RE 4400 iQ, RE 4600 iQ, RA 6800 iQ and RA 6900 iQ

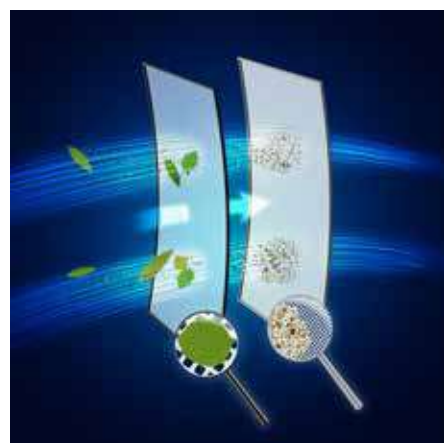

ELECTRIC CLEANERS







A stand-alone and efficient solution

COMPARATIVE TABLE OF RANGES TECHNICAL SPECIFICATIONS		RT 2100	RT 3200	RC 4380	RC 4400 RC 4402	RE 4200	RE 4300	RE 4400 iQ	RE 4600 iQ
									
Types of pools	Surfaces	Liner, polyester hull, reinforced PVC, painted concrete, Tiles *	Liner, polyester hull, reinforced PVC, painted concrete, Tiles *	Liner, reinforced PVC, painted concrete , polyester hull, Tiles : dedicated brushes kit	Liner, reinforced PVC, painted concrete , polyester hull, Tiles : dedicated brushes kit	Tiles, liner, polyester hull, reinforced PVC, painted concrete	Tiles, liner, polyester hull, reinforced PVC, painted concrete	Tiles, liner, polyester hull, reinforced PVC, painted concrete	Tiles, liner, polyester hull, reinforced PVC, painted concrete
	Shapes	Rectangular, oval, free shape	Rectangular, oval, free shape	Rectangular, oval, free shape	Rectangular, oval, free shape	Rectangular, oval, free shape	Rectangular, oval, free shape	Rectangular, oval, free shape	Rectangular, oval, free shape
	Bottom	Flat, gentle slope, composite slope	Flat, gentle slope, composite slope	Flat, gentle slope, composite slope, diamond shape	Flat, gentle slope, composite slope, diamond shape	Flat, gentle slope, composite slope, diamond shape	Flat, gentle slope, composite slope, diamond shape	Flat, gentle slope, composite slope, diamond shape	Flat, gentle slope, composite slope, diamond shape
	Size	8 x 4 m (14 m cable)	9 x 4 m (16,5m cable)	10 x 5 m (15 m cable)	12 x 6 m (18m cable)	10 x 5m (15m cable)	10 x 5m (15m cable)	12 x 6 m (18m cable)	12 x 6 m (18m cable)
Performance	Traction	Tracks - 1 motor	Tracks - 1 motor	Tracks - 1 motor	Tracks - 1 motor	Tracks - 2 motors	Tracks - 2 motors	Tracks - 2 motors	Tracks - 2 motors
	Cleaning areas	Floor	Floor / walls	Floor / walls / waterline	Floor / walls / waterline	Floor / walls / waterline	Floor / walls / waterline	Floor / walls / waterline	Floor / walls / waterline
	Cyclonic Suction	-	-	-	-	✓	✓	✓	✓
	Filtering level	100µ	100µ	100µ	100µ	100µ	526 cm ² 150/60µ	150/60µ	150/60µ
	Filter capacity	3 L	3 L	3,7 L	3,7 L	4 L	4 L	4 L	4 L
	Swivel	-	-	-	-	-	-	-	-
	Sensor Nav System™	-	-	-	-	-	-	-	-
	Remote control	-	-	-	-	-	-	-	✓ via the app
Type of brush	Standard	Standard	Standard	Standard	Helix shaped	Helix shaped	Helix shaped	Helix shaped	
Cycles	Number of cycles	1	1	2	6	2	2	2	2
	Cleaning cycles	Floor	Floor / walls	Floor «Deep Clean» Floor / walls / waterline	Floor «Deep Clean» Floor / walls / waterline	Floor only Floor / walls / waterline	Floor only Floor / walls / waterline	Floor only Floor / walls / waterline	Floor only Floor / walls / waterline
	Manual cleaning time adjustment	-	-	-	✓	-	-	-	-
Ease of use	iAqualink™ app control	-	-	-	-	-	-	✓	✓
	Lift System	-	-	-	-	-	-	-	✓
	7-day timer	-	-	-	-	-	-	-	-
	Full filter indicator	-	-	-	✓	-	-	-	-
	Transparent window	-	✓	✓	✓	✓	✓	✓	✓
	Illuminated filter	-	-	-	-	-	-	✓	✓
	Type of filter	Rigid Filter canister with access over the cleaner	Rigid Filter canister with access over the cleaner	Rigid Filter canister with access over the cleaner	Rigid Filter canister with access over the cleaner	Rigid Filter canister / Top access	Rigid Filter canister / Top access	Rigid Filter canister / Top access	Rigid Filter canister / Top access
Trolley	-	-	✓	✓	-	-	-	✓	
Advanced app features	Water temperature display	-	-	-	-	-	-	-	-
	Spot cleaning mode	-	-	-	-	-	-	-	-
Warranty	2 years	2 years	2 years	2 years	2 years	2 years	3 years**	3 years*	

*For optimal cleaner behavior in some tile pools, it might be necessary to use the specific tile brush accessory.

**2 years + 1 year if the cleaner is paired to iAqualink™

**COMPARATIVE
TABLE
OF RANGES**
TECHNICAL
SPECIFICATIONS

	RV 5300	RV 5380	RA 6300 iQ	RA 6500 iQ	RA 6700 iQ	RA 6800 iQ	RA 6900 iQ	
								
Types of pools	Surfaces	Tiles, liner, polyester hull, reinforced PVC, painted concrete	Tiles, liner, polyester hull, reinforced PVC, painted concrete	Tiles, liner, polyester hull, reinforced PVC, painted concrete	Tiles, liner, polyester hull, reinforced PVC, painted concrete	Tiles, liner, polyester hull, reinforced PVC, painted concrete	Tiles, liner, polyester hull, reinforced PVC, painted concrete	
	Shapes	Rectangular, oval, free shape	Rectangular, oval, free shape	Rectangular, oval, free shape	Rectangular, oval, free shape	Rectangular, oval, free shape	Rectangular, oval, free shape	
	Bottom	Flat, gentle slope, composite slope, diamond shape	Flat, gentle slope, composite slope, diamond shape	Flat, gentle slope, composite slope, diamond shape	Flat, gentle slope, composite slope, diamond shape	Flat, gentle slope, composite slope, diamond shape	Flat, gentle slope, composite slope, diamond shape	
	Size	12 x 6 m (18m cable)	12 x 6 m (18m with Swivel cable)	12 x 6 m (18m with Swivel cable)	12 x 6 m (18m with Swivel cable)	15 x 7 m (21m with Swivel cable)	15 x 7 m (21m with Swivel cable)	20 x 10 m (25m with Swivel cable)
Performance	Traction	4 wheel drive 2 motors	4 wheel drive 2 motors	4 wheel drive 2 motors	4 wheel drive 2 motors	4 wheel drive 2 motors	4 wheel drive 2 motors	
	Cleaning areas	Floor / walls / waterline	Floor / walls / waterline	Floor / walls / waterline	Floor / walls / waterline	Floor / walls / waterline	Floor / walls / waterline	
	Cyclonic Suction	✓	✓	✓	✓	✓	✓	
	Filtering level	100µ	100µ	60µ	60µ	60µ	150 and 60µ	150 and 60µ
	Filter capacity	5 L	5 L	5 L	5 L	5 L	5 L	5 L
	Swivel	✓	✓	✓	✓	✓	✓	✓
	Sensor Nav System™	-	-	✓	✓	✓	✓	✓
	Remote control	-	-	-	(with app)	(with app)	(with app)	(with app)
	Type of brush	Contact +	Contact +	Contact +	Contact +	Contact +	Contact +	Contact +
Cycles	Number of cycles	2	2	2	Multiple	Multiple	Multiple	Multiple
	Cleaning cycles	Floor only Floor / walls / waterline	Floor only Floor / walls / waterline	Quick floor only Smart floor/ walls / waterline (calculated time)	Quick floor only Smart floor/ walls / waterline (calculated time) Ultra floor / walls / waterline	Quick floor only Smart floor/ walls / waterline (calculated time) Ultra floor / walls / waterline Waterline only	Quick floor only Smart floor/ walls / waterline (calculated time) Ultra floor / walls / waterline Waterline only	Multiple from 0h30 to 6h with preset cycles Quick floor only Smart floor/ walls / waterline (calculated time) Ultra floor / walls / waterline Waterline only
	Manual cleaning time adjustment	-	-	-	✓	✓	✓	✓
Ease of use	iAqualink™ app control	-	-	✓	✓	✓	✓	✓
	Lift System	-	✓	✓	✓	✓	✓	✓
	7-day timer	-	-	-	✓	✓	✓	✓
	Full filter indicator	✓	✓	✓	✓	✓	✓	✓
	Transparent window	-	-	✓	✓	✓	✓	✓
	Illuminated filter	-	-	✓	✓	✓	✓	✓
	Type of filter	Rigid Filter canister with access over the cleaner	Rigid Filter canister with access over the cleaner	Rigid Filter canister with access over the cleaner	Rigid Filter canister with access over the cleaner	Rigid Filter canister with access over the cleaner	Rigid Filter canister with access over the cleaner	Rigid Filter canister with access over the cleaner
Trolley	✓	✓	✓	✓	✓	✓	✓	
Advanced app features	Water temperature display	-	-	-	-	✓ (info in app)	✓ (info in app)	✓ (info in app)
	Spot cleaning mode	-	-	-	-	✓	✓	✓
Warranty	3 years	3 years	4 years**	4 years**	4 years**	4 years**	4 years**	

*** 3 years + 1 year if the cleaner is paired to iAqualink™

TORNAX

Efficiency, pure and simple



**COMPARATIVE
TABLE
OF RANGES**
TECHNICAL SPECIFICATIONS

		RT 2100	RT 3200
			
Types of pools	Surfaces	Liner, polyester hull, reinforced PVC, painted concrete, Tiles *	Liner, polyester hull, reinforced PVC, painted concrete, Tiles *
	Shapes	Rectangular, oval, free shape	Rectangular, oval, free shape
	Size	8 x 4 m (14 m cable)	9 x 4 m (16,5m cable)
Performance	Traction	Tracks - 1 motor	Tracks - 1 motor
	Cleaning areas	Floor	Floor / walls
	Cyclonic Suction	-	-
	Filtering level	100µ	100µ
	Filter capacity	3 L	3 L
	Swivel	-	-
	Sensor Nav System™	-	-
	Remote control	-	-
Cycles	Number of cycles	1	1
	Cleaning cycles	Floor	Floor / walls
	Manual cleaning time adjustment	-	-
Ease of use	iAqualink™ app control	-	-
	Lift System	-	-
	7-day timer	-	-
	Full filter indicator	-	-
	Transparent window	-	✓
	Illuminated filter	-	-
	Type of filter	Rigid Filter canister with access over the cleaner	Rigid Filter canister with access over the cleaner
	Trolley	-	-
	Warranty	2 years	2 years

ELECTRIC CLEANERS

RT 2100 - TORNAX PRO



EFFICIENCY, PURE AND SIMPLE

- + Efficient floor cleaning
- + Lightweight for effortless handling
- + Easy clean filter



REFERENCE PRICE	
Standard Model	WR000092

ACCESSORIES INCLUDED IN THE PACK

Control box	Fine Filter canister 100µ	Control box base

FOR WHICH TYPE OF POOLS?

Types of pools	Private in-ground pools and above-ground pools with rigid walls, maximum 8 x 4 m
Pool shapes	Rectangular, oval, free shape
All Floors	Flat, gentle slope, composite slope
Pool surfaces	Liner, polyester hull, reinforced PVC, painted concrete, Tiles *

DESCRIPTION	
Cleaning areas	Floor
Number / Length of cleaning cycles	1 cycle - Floor : 2h30
Power supply	Autonomous, connected to 230V mains supply before the transformer
Steering	Pre-programmed
Drive system	Tracks - 1 motor
Transmission	Gear transmission
Brushes	Yes
Transparent window	No
Safety	Deck system, out of water safety, diagnostic, electronic motor protector
Filtration system / access	Rigid Filter canister with access over the cleaner
Units / pallet	36

TECHNICAL SPECIFICATIONS	
Number of motors	2
Control box supply	100-240 VAC ; 50 / 60 Hz
Power supply	30 VDC
Operating power	100 W
Cable length / Hose length	14 m
Cleaner size (L x W x h)	37 x 29 x 30 cm
Packaging size (L x W x h)	56 x 37 x 38 cm
Cleaner weight	5,5 kg
Packaging weight	10 kg
Filtering surface and level	480 cm ² / 100µ
Filtering capacity	3 L
Inlet suction size	17 cm

OPTIONAL ACCESSORIES (NOT INCLUDED)

Ultra-fine filter canister 60µ	Fine filter canister 100µ	Large debris filter canister 200µ	Trolley	Special tile brush (unit)
R0763100	R0762900	R0763000	R0767600	R0774900

*For optimal cleaner behavior in some tile pools, it might be necessary to use the specific tile brush accessory.

ELECTRIC CLEANERS

RT 3200 - TORNAX PRO



EFFICIENCY, PURE AND SIMPLE

- + Efficient floor and walls cleaning
- + Lightweight for effortless handling
- + Easy clean filter

2 YEAR WARRANTY

REFERENCE PRICE

Standard Model	WR000093
----------------	----------

ACCESSORIES INCLUDED IN THE PACK

		
Control box	Fine Filter canister 100µ	Control box base

FOR WHICH TYPE OF POOLS?

Types of pools	Private in-ground pools and above-ground pools with rigid walls, maximum 9 x 4 m
Pool shapes	Rectangular, oval, free shape
All Floors	Flat, gentle slope, composite slope
Pool surfaces	Liner, polyester hull, reinforced PVC, painted concrete, Tiles *

DESCRIPTION	
Cleaning areas	Floor / walls
Number / Length of cleaning cycles	1 cycle - Floor / walls : 3h
Power supply	Autonomous, connected to 230V mains supply before the transformer
Steering	Pre-programmed
Drive system	Tracks - 1 motor
Transmission	Gear transmission
Brushes	Yes
Transparent window	Yes
Safety	Deck system, out of water safety, diagnostic, electronic motor protector
Filtration system / access	Rigid Filter canister with access over the cleaner
Units / pallet	36

TECHNICAL SPECIFICATIONS	
Number of motors	2
Control box supply	100-240 VAC ; 50 / 60 Hz
Power supply	30 VDC
Operating power	100 W
Cable length / Hose length	16,5m
Cleaner size (L x W x h)	37 x 29 x 30 cm
Packaging size (L x W x h)	56 x 37 x 38 cm
Cleaner weight	5,5 kg
Packaging weight	11 kg
Filtering surface and level	480 cm ² / 100µ
Filtering capacity	3 L
Inlet suction size	17 cm

OPTIONAL ACCESSORIES (NOT INCLUDED)

Ultra-fine filter canister 60µ	Fine filter canister 100µ	Large debris filter canister 200µ	Trolley	Special tile brush (unit)
R0763100	R0762900	R0763000	R0767600	R0774900

*For optimal cleaner behavior in some tile pools, it might be necessary to use the specific tile brush accessory.

CYCLONX™

The essentials of Zodiac® technology



COMPARATIVE TABLE OF RANGES

TECHNICAL SPECIFICATIONS

		RC 4380	RC 4400	RC 4402
Types of pools	Surfaces	Liner, reinforced PVC, painted concrete , polyester hull, Tiles : dedicated brushes kit	Liner, reinforced PVC, painted concrete , polyester hull, Tiles : dedicated brushes kit	Slippery surfaces (polyester hull, tile)
	Shapes	Rectangular, oval, free shape	Rectangular, oval, free shape	Rectangular, oval, free shape
	Size	10 x 5 m (15 m cable)	12 x 6 m (18m cable)	12 x 6 m (18m cable)
Performance	Traction	Tracks - 1 motor	Tracks - 1 motor	Tracks - 1 motor
	Cleaning areas	Floor / walls / waterline	Floor / walls / waterline	Floor / walls / waterline
	Cyclonic Suction	-	-	-
	Filtering level	100µ	100µ	100µ
	Filter capacity	3,7 L	3,7 L	3,7 L
	Swivel	-	-	-
	Sensor Nav System™	-	-	-
	Remote control	-	-	-
Cycles	Type of brush	Standard	Standard	Standard
	Number of cycles	2	6	6
	Cleaning cycles	Floor «Deep Clean» Floor / walls / waterline	Floor «Deep Clean» Floor / walls / waterline	Floor «Deep Clean» Floor / walls / waterline
	Manual cleaning time adjustment	-	-	✓
Ease of use	iAqualink™ app control	-	-	-
	Lift System	-	-	-
	7-day timer	-	-	-
	Full filter indicator	-	✓	✓
	Transparent window	✓	✓	✓
	Illuminated filter	-	-	-
	Type of filter	Rigid Filter canister with access over the cleaner	Rigid Filter canister with access over the cleaner	Rigid Filter canister with access over the cleaner
	Trolley	✓	✓	✓
Warranty	2 years	2 years	2 years	

ELECTRIC CLEANERS

RC 4380 - CYCLONX™ PRO



CONCENTRATED TECHNOLOGY

- + Optimal cleaning for the floor/walls/water line
- + Large suction capacity
- + Filter access at the push of a button



REFERENCE PRICE

Standard Model	WR000240
----------------	----------

ACCESSORIES INCLUDED IN THE PACK

Control box	Fine Filter canister 100µ	Control box base

FOR WHICH TYPE OF POOLS?

Types of pools	Private in-ground pools and above-ground pools with rigid walls, maximum 10 x 5 m
Pool shapes	Rectangular, oval, free shape
All Floors	Flat, gentle slope, composite slope, diamond shape
Pool surfaces	Liner, reinforced PVC, painted concrete , polyester hull, Tiles : dedicated brushes kit

DESCRIPTION

Cleaning areas	Floor / walls / waterline
Number / Length of cleaning cycles	2 cycles : - Floor «Deep Clean» : 1h30 - Floor / walls / waterline : 1h30
Power supply	Autonomous, connected to 230V mains supply before the transformer
Steering	Pre-programmed
Drive system	Tracks - 1 motor
Transmission	Gear transmission
Brushes	Yes
Lift System	no
Transparent window	Yes
Full filter indicator	No
Remote control	No
Safety	Deck system, out of water safety, diagnostic, electronic motor protector
Filtration system / access	Rigid Filter canister with access over the cleaner
Units / pallet	20

TECHNICAL SPECIFICATIONS

Number of motors	2
Control box supply	200-240 VAC ; 50 / 60 Hz
Power supply	30 VDC
Operating power	150 W
Cable length / Hose length	15 m
Cleaner size (L x W x h)	41 x 42 x 28 cm
Packaging size (L x W x h)	56 x 56 x 38 cm
Cleaner weight	9 kg
Packaging weight	17,1 kg
Filtering surface and level	850 cm ² / 100µ
Filtering capacity	3,7 L
Inlet suction size	22 cm

OPTIONAL ACCESSORIES (NOT INCLUDED)

Ultra-fine filter canister 60µ	Large debris filter canister 200µ	Fine filter canister 100µ	Protective cover	Trolley	Kit for polyester hull pools (2 brushes)	Kit for slippery surfaces (2 brushes)
R0632602	R0632601	R0632600	R0568100	R0639500	R0697600	R0718600

ELECTRIC CLEANERS

RC 4400 - CYCLONX™ PRO



CONCENTRATED TECHNOLOGY

- + Optimal cleaning for the floor/walls/water line
- + Large suction capacity
- + Filter access at the push of a button

REFERENCE PRICE

Standard Model	WR000021
----------------	----------

ACCESSORIES INCLUDED IN THE PACK



Trolley



Control box



Fine Filter canister 100µ

FOR WHICH TYPE OF POOLS?

Types of pools	Private in-ground pools and above-ground pools with rigid walls, maximum 12 x 6 m
Pool shapes	Rectangular, oval, free shape
All Floors	Flat, gentle slope, composite slope, diamond shape
Pool surfaces	Liner, reinforced PVC, painted concrete, polyester hull, Tiles : dedicated brushes kit

DESCRIPTION

Cleaning areas	Floor / walls / waterline
Number / Length of cleaning cycles	6 cycles : - Floor «Deep Clean» : 1h, 1h30, 2h - Floor / walls / waterline : 1h, 1h30, 2h
Power supply	Autonomous, connected to 230V mains supply before the transformer
Steering	Pre-programmed
Drive system	Tracks - 1 motor
Transmission	Gear transmission
Brushes	Yes
Lift System	no
Transparent window	Yes
Full filter indicator	Yes
Remote control	No
Safety	Deck system, out of water safety, diagnostic, electronic motor protector
Filtration system / access	Rigid Filter canister with access over the cleaner
Units / pallet	16

TECHNICAL SPECIFICATIONS

Number of motors	2
Control box supply	200-240 VAC ; 50 / 60 Hz
Power supply	30 VDC
Operating power	150 W
Cable length / Hose length	18m
Cleaner size (L x W x h)	41 x 42 x 28 cm
Packaging size (L x W x h)	56 x 56 x 46 cm
Cleaner weight	9,5 kg
Packaging weight	19,1 kg
Filtering surface and level	850 cm ² / 100µ
Filtering capacity	3,7 L
Inlet suction size	22 cm

OPTIONAL ACCESSORIES (NOT INCLUDED)

Ultra-fine filter canister 60µ	Large debris filter canister 200µ	Fine filter canister 100µ	Protective cover	Kit for polyester hull pools (2 brushes)	Kit for slippery surfaces (2 brushes)
R0632602	R0632601	R0632600	R0568100	R0697600	R0718600

ELECTRIC CLEANERS

RC 4402 - CYCLONX™ PRO



CONCENTRATED TECHNOLOGY

- + Adapted for pools with slippery surfaces (polyester hull, tile)
- + Optimal cleaning for the floor/walls/water line
- + Large suction capacity
- + Filter access at the push of a button



REFERENCE PRICE

Standard Model

WR000239

ACCESSORIES INCLUDED IN THE PACK

Trolley	Control box	Fine Filter canister 100µ

FOR WHICH TYPE OF POOLS?

Types of pools	Private in-ground pools and above-ground pools with rigid walls, maximum 12 x 6 m
Pool shapes	Rectangular, oval, free shape
All Floors	Flat, gentle slope, composite slope, diamond shape
Pool surfaces	Slippery surfaces (polyester hull, tile)

DESCRIPTION

Cleaning areas	Floor / walls / waterline
Number / Length of cleaning cycles	6 cycles : - Floor «Deep Clean» : 1h, 1h30, 2h - Floor / walls / waterline : 1h, 1h30, 2h
Power supply	Autonomous, connected to 230V mains supply before the transformer
Steering	Pre-programmed
Drive system	Tracks - 1 motor
Transmission	Gear transmission
Brushes	Yes
Lift System	no
Transparent window	Yes
Full filter indicator	Yes
Remote control	No
Safety	Deck system, out of water safety, diagnostic, electronic motor protector
Filtration system / access	Rigid Filter canister with access over the cleaner
Units / pallet	16

TECHNICAL SPECIFICATIONS

Number of motors	2
Control box supply	200-240 VAC ; 50 / 60 Hz
Power supply	30 VDC
Operating power	150 W
Cable length / Hose length	18m
Cleaner size (L x W x h)	41 x 42 x 28 cm
Packaging size (L x W x h)	56 x 56 x 46 cm
Cleaner weight	9,5 kg
Packaging weight	19,1 kg
Filtering surface and level	850 cm ² / 100µ
Filtering capacity	3,7 L
Inlet suction size	22 cm

OPTIONAL ACCESSORIES (NOT INCLUDED)

Ultra-fine filter canister 60µ	Large debris filter canister 200µ	Fine filter canister 100µ	Protective cover
R0632602	R0632601	R0632600	R0568100

VOYAGER™

Full on agility



RE 4300



> OPTIMAL CLEANING PERFORMANCE

Its patented cyclonic suction is powerful and long-lasting. Its helix shaped brushes and dual stage progressive filtration collect all debris more efficiently, even the smallest ones.

With VOYAGER™, your pool will be perfectly clean all year round.



> INTEGRATED AGILITY

With its embedded smart sensors and its unique design, VOYAGER™ offers excellent pool coverage and agility. Thus, it is ideal for all pool shapes and surfaces.



> EASE OF USE

Its backlit top access filter, and its transparent window offers real daily ease of use.



DUAL STAGE FILTRATION

Progressive filtration 60µ and 150µ



VOYAGER™

Full on agility

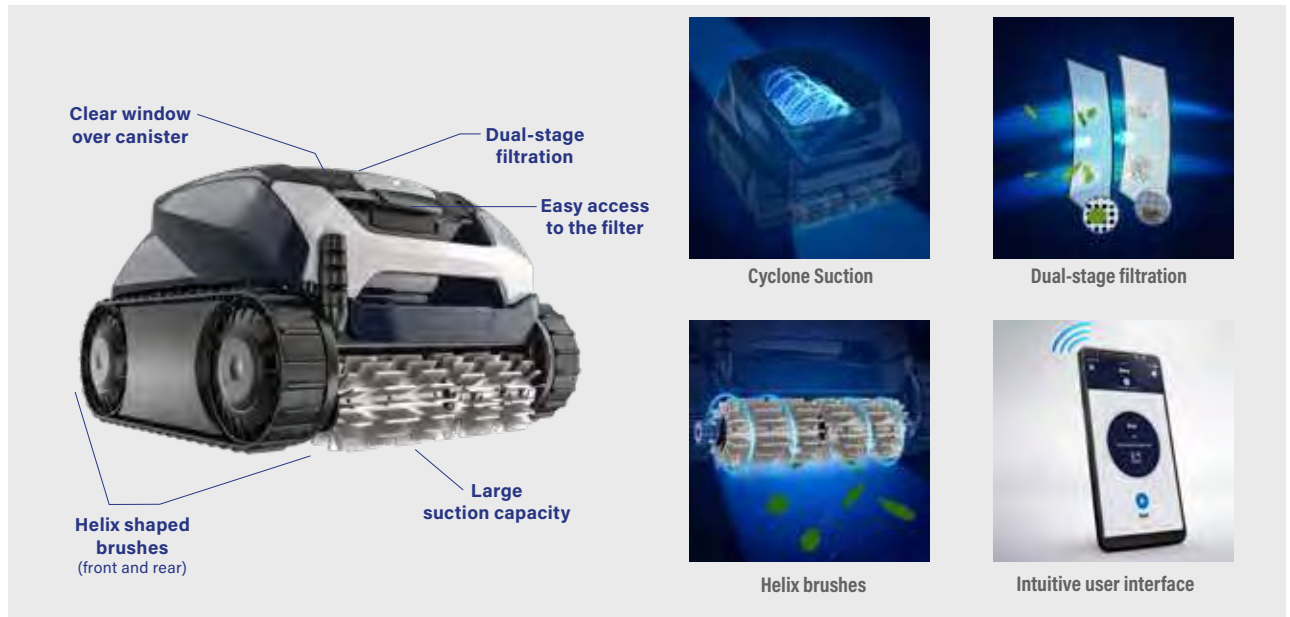

**COMPARATIVE
TABLE
OF RANGES**

TECHNICAL SPECIFICATIONS

		RE 4200	RE 4300	RE 4400 iQ	RE 4600 iQ
Types of pools	Surfaces	Tiles, liner, polyester hull, reinforced PVC, painted concrete	Tiles, liner, polyester hull, reinforced PVC, painted concrete	Tiles, liner, polyester hull, reinforced PVC, painted concrete	Tiles, liner, polyester hull, reinforced PVC, painted concrete
	Shapes	Rectangular, oval, free shape	Rectangular, oval, free shape	Rectangular, oval, free shape	Rectangular, oval, free shape
	Bottom	Flat, gentle slope, composite slope, diamond shape	Flat, gentle slope, composite slope, diamond shape	Flat, gentle slope, composite slope, diamond shape	Flat, gentle slope, composite slope, diamond shape
	Size	10 x 5m (15m cable)	10 x 5m (15m cable)	12 x 6 m (18m cable)	12 x 6 m (18m cable)
Performance	Traction	Tracks - 2 motors	Tracks - 2 motors	Tracks - 2 motors	Tracks - 2 motors
	Cleaning areas	Floor / walls / waterline	Floor / walls / waterline	Floor / walls / waterline	Floor / walls / waterline
	Cyclonic Suction	✓	✓	✓	✓
	Filtering level	100µ	526 cm ² 150/60µ	150/60µ	150/60µ
	Filter capacity	4 L	4 L	4 L	4 L
	Swivel	-	-	-	-
	Sensor Nav System™	-	-	-	-
	Remote control	-	-	-	✓ via the app
Type of brush	Helix shaped	Helix shaped	Helix shaped	Helix shaped	
Cycles	Number of cycles	2	2	2	2
	Cleaning cycles	Floor only Floor / walls / waterline	Floor only Floor / walls / waterline	Floor only Floor / walls / waterline	Floor only Floor / walls / waterline
	Manual cleaning time adjustment	-	-	-	-
Ease of use	iAqualink™ app control	-	-	✓	✓
	Lift System	-	-	-	✓
	7-day timer	-	-	-	-
	Full filter indicator	-	-	-	-
	Transparent window	✓	✓	✓	✓
	Illuminated filter	-	-	✓	✓
	Type of filter	Rigid Filter canister / Top access	Rigid Filter canister / Top access	Rigid Filter canister / Top access	Rigid Filter canister / Top access
Trolley	-	-	-	✓	
Advanced app features	Water temperature display	-	-	-	-
	Spot cleaning mode	-	-	-	-
Warranty	2 years		3 years*	3 years*	

*2 years + 1 year if the cleaner is paired to iAqualink™

ELECTRIC CLEANERS

RE 4200 - VOYAGER™



FULL ON AGILITY

- + Optimal cleaning performance : Patented cyclonic suction / Helix shaped brushes / Large suction capacity
- + Integrated agility : Designed to work in all pool shapes or surfaces / Tracks / accelerometer & gyroscope sensors
- + Ease of use : Top access filter / transparent window



REFERENCE PRICE

Standard Model	WR000331
----------------	----------

ACCESSORIES INCLUDED IN THE PACK



Control box



Fine Filter canister 100µ



Control box base

FOR WHICH TYPE OF POOLS?

Types of pools	Private in-ground pools and above-ground pools with rigid walls, maximum 10 x 5m
Pool shapes	Rectangular, oval, free shape
All Floors	Flat, gentle slope, composite slope, diamond shape
Pool surfaces	Tiles, liner, polyester hull, reinforced PVC, painted concrete

DESCRIPTION

Cleaning areas	Floor / walls / waterline
Number / Length of cleaning cycles	2 cycles : - Floor only : 1h30 - Floor / walls / waterline : 2h30
Timer	No
Power supply	Autonomous, connected to 230V mains supply before the transformer
Steering	Pre-programmed
Drive system	Tracks - 2 motors
Transmission	Gear transmission
Pressure sensor	No
Brushes	Yes - front brushes
Lift System	No
Transparent window	Yes
Full filter indicator	No
Remote control	No
Water temperature measurement	No
Safety	Deck system, out of water safety, diagnostic, electronic motor protector
Filtration system / access	Rigid Filter canister / Top access
Units / pallet	20

TECHNICAL SPECIFICATIONS

Number of motors	3
Control box supply	200-240 VAC ; 50 / 60 Hz
Power supply	30 VDC
Operating power	150 W
Cable length / Hose length	15m
Cleaner size (L x W x h)	43 x 40 x 30 cm
Packaging size (L x W x h)	56 x 56 x 37 cm
Cleaner weight	8 kg
Packaging weight	14kg
Filtering surface and level	526 cm ² / 100µ
Filtering capacity	4L
Inlet suction size	23 cm

OPTIONAL ACCESSORIES (NOT INCLUDED)

Main canister 200µ for single filter	Main canister 150µ for dual stage filter	Over canister 60µ for dual stage filter	Protective cover	Trolley
R0897700	R0897600	R0898100	R0568100	R0639500

ELECTRIC CLEANERS

RE 4300 - VOYAGER™



FULL ON AGILITY

- + Optimal cleaning performance : Patented cyclonic suction / Helix shaped brushes / Progressive dual stage filtration 150/60µ
- + Integrated agility : Designed to work in all pool shapes or surfaces / Tracks / accelerometer & gyroscope sensors
- + Ease of use : Top access filter / transparent window





REFERENCE PRICE

Standard Model

WR000449

ACCESSORIES INCLUDED IN THE PACK

		
Control box	Dual Filter canister 60µ / 150µ	Control box base

FOR WHICH TYPE OF POOLS?

Types of pools	Private in-ground pools and above-ground pools with rigid walls, maximum 10 x 5m
Pool shapes	Rectangular, oval, free shape
All Floors	Flat, gentle slope, composite slope, diamond shape
Pool surfaces	Tiles, liner, polyester hull, reinforced PVC, painted concrete

DESCRIPTION

Cleaning areas	Floor / walls / waterline
Number / Length of cleaning cycles	2 cycles : - Floor only : 1h30 - Floor / walls / waterline : 2h30
Cleaning cycles	2
Timer	No
Power supply	Autonomous, connected to 230V mains supply before the transformer
Steering	Pre-programmed
Drive system	Tracks - 2 motors
Transmission	Gear transmission
Pressure sensor	No
Brushes	Yes - front brushes
Lift System	No
Transparent window	Yes
Full filter indicator	No
Remote control	No
Water temperature measurement	No
Safety	Deck system, out of water safety, diagnostic, electronic motor protector
Filtration system / access	Rigid Filter canister / Top access
Units / pallet	20

TECHNICAL SPECIFICATIONS

Number of motors	3
Control box supply	200-240 VAC ; 50 / 60 Hz
Power supply	30 VDC
Operating power	150 W
Cable length / Hose length	15m
Cleaner size (L x W x h)	43 x 40 x 30 cm
Packaging size (L x W x h)	56 x 56 x 37 cm
Cleaner weight	8 kg
Packaging weight	14kg
Filtering surface and level	526 cm ² 150/60µ
Filtering capacity	4L
Inlet suction size	23 cm

OPTIONAL ACCESSORIES (NOT INCLUDED)

Main canister 100µ for single filter	Main canister 200µ for single filter	Protective cover	Trolley
R0897500	R0897700	R0568100	R0639500

ELECTRIC CLEANERS

RE 4400 iQ - VOYAGER™



3 YEAR WARRANTY*



FULL ON AGILITY

- + Optimal cleaning performance : Patented cyclonic suction / Helix shaped brushes / progressive dual stage filtration 150/60µ
- + Integrated agility : Designed to work in all pool shapes or surfaces / Tracks / accelerometer & gyroscope sensors
- + Control via iAqualink™ app : basic features
- + Ease of use : Top access filter / transparent window

REFERENCE PRICE

Standard Model	WR000327
----------------	----------

ACCESSORIES INCLUDED IN THE PACK

Control box	Dual Filter canister 60µ and 150µ	Control box base	Free app

FOR WHICH TYPE OF POOLS?

Types of pools	Private in-ground pools and above-ground pools with rigid walls,
Pool shapes	Rectangular, oval, free shape
All Floors	Flat, gentle slope, composite slope, diamond shape
Pool surfaces	Tiles, liner, polyester hull, reinforced PVC, painted concrete

DESCRIPTION

Cleaning areas	Floor / walls / waterline
Number / Length of cleaning cycles	2 cycles : - Floor only : 1h30 - Floor / walls / waterline : 2h30
Timer	No
Power supply	Autonomous, connected to 230V mains supply before the transformer
Steering	Pre-programmed
Drive system	Tracks - 2 motors
Transmission	Gear transmission
Pressure sensor	No
Brushes	Yes - front and rear brushes
Lift System	No
Transparent window	Yes
Full filter indicator	No
Remote control	No
Water temperature measurement	No
Safety	Deck system, out of water safety, diagnostic, electronic motor protector
Filtration system / access	Rigid Filter canister / Top access
Units / pallet	20

TECHNICAL SPECIFICATIONS

Number of motors	3
Control box supply	200-240 VAC ; 50 / 60 Hz
Power supply	30 VDC
Operating power	150 W
Cable length / Hose length	18m
Cleaner size (L x W x h)	43 x 40 x 30 cm
Packaging size (L x W x h)	56 x 56 x 37 cm
Cleaner weight	8 kg
Packaging weight	14kg
Filtering surface and level	1066 cm ² 150/60µ
Filtering capacity	4L
Inlet suction size	23 cm

OPTIONAL ACCESSORIES (NOT INCLUDED)

Main canister 100µ for single filter	Main canister 200µ for single filter	Protective cover	Trolley
R0897500	R0897700	R0568100	R0639500

* 2 years + 1 year if the cleaner is paired to iAqualink™

ELECTRIC CLEANERS

RE 4600 iQ - VOYAGER™



FULL ON AGILITY

- + Optimal cleaning performance : Patented cyclonic suction / Helix shaped brushes / progressive dual stage filtration 150/60µ
- + Integrated agility : Designed to work in all pool shapes or surfaces / Tracks / accelerometer & gyroscope sensors
- + Control via iAqualink™ app : advanced features
- + Ease of use : Top access filter / transparent window / trolley

REFERENCE PRICE

Standard Model	WR000323
----------------	----------

ACCESSORIES INCLUDED IN THE PACK

Trolley	Control box	Dual Filter canister 60µ and 150µ	Free app

FOR WHICH TYPE OF POOLS?

Types of pools	Private in-ground pools and above-ground pools with rigid walls, maximum 12 x 6 m
Pool shapes	Rectangular, oval, free shape
All Floors	Flat, gentle slope, composite slope, diamond shape
Pool surfaces	Tiles, liner, polyester hull, reinforced PVC, painted concrete

DESCRIPTION

Cleaning areas	Floor / walls / waterline
Number / Length of cleaning cycles	2 cycles : - Floor only : 1h30 - Floor / walls / waterline : 2h30
Timer	No
Power supply	Autonomous, connected to 230V mains supply before the transformer
Steering	Pre-programmed
Drive system	Tracks - 2 motors
Transmission	Gear transmission
Pressure sensor	No
Brushes	Yes - front and rear brushes
Lift System	Yes
Transparent window	Yes
Full filter indicator	No
Remote control	Yes via the app
Water temperature measurement	No
Safety	Deck system, out of water safety, diagnostic, electronic motor protector
Filtration system / access	Rigid Filter canister / Top access
Units / pallet	16

TECHNICAL SPECIFICATIONS

Number of motors	3
Control box supply	200-240 VAC ; 50 / 60 Hz
Power supply	30 VDC
Operating power	150 W
Cable length / Hose length	18m
Cleaner size (L x W x h)	43 x 40 x 30 cm
Packaging size (L x W x h)	56 x 56 x 47 cm
Cleaner weight	8 kg
Packaging weight	15 kg
Filtering surface and level	1066 cm ² 150/60µ
Filtering capacity	4L
Inlet suction size	23 cm

OPTIONAL ACCESSORIES (NOT INCLUDED)

Main canister 100µ for single filter	Main canister 200µ for single filter	Protective cover
R0897500	R0897700	R0568100

* 2 years + 1 year if the cleaner is paired to iAqualink™

VORTEX™ 4WD RANGE

Ultimate power

COMMON FEATURES OF THE PRO RANGE

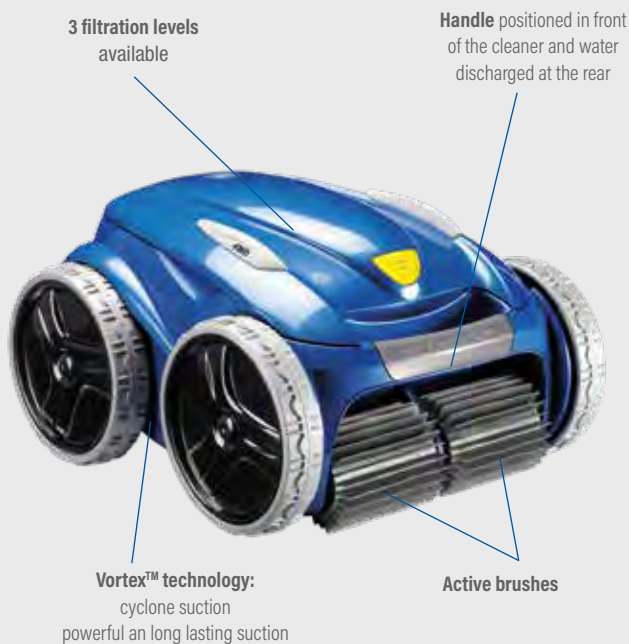

Filter basket with easy access and large capacity (5 L)



Patented Lift System*



Extra-wide suction inlet

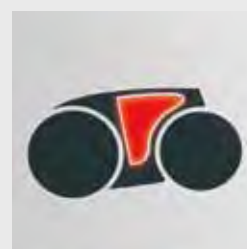

Filter full indicator

*depending on model

COMPARATIVE TABLE OF RANGES

TECHNICAL SPECIFICATIONS

		RV 5300	RV 5380
Types of pools	Surfaces	Tiles, liner, polyester hull, reinforced PVC, painted concrete	Tiles, liner, polyester hull, reinforced PVC, painted concrete
	Shapes	Rectangular, oval, free shape	Rectangular, oval, free shape
	Size	12 x 6 m (18m cable)	12 x 6 m (18m with Swivel cable)
Performance	Traction	4 wheel drive - 2 motors	4 wheel drive - 2 motors
	Cleaning areas	Floor / walls / waterline	Floor / walls / waterline
	Cyclonic Suction	✓	✓
	Filtering level	100µ	100µ
	Filter capacity	5 L	5 L
	Swivel	✓	✓
	Sensor Nav System™	-	-
	Remote control	-	-
	Type of brush	Contact +	Contact +
Cycles	Number of cycles	2	2
	Cleaning cycles	Floor only Floor / walls / waterline	Floor only Floor / walls / waterline
	Manual cleaning time adjustment	-	-
Ease of use	iAqualink™ app control	-	-
	Lift System	-	✓
	7-day timer	-	-
	Full filter indicator	✓	✓
	Transparent window	-	-
	Illuminated filter	-	-
	Type of filter	Rigid Filter canister with access over the cleaner	Rigid Filter canister with access over the cleaner
	Trolley	✓	✓
Warranty	3 years	3 years	



ELECTRIC CLEANERS

RV 5300 - VORTEX™ PRO 4WD



ULTIMATE POWER IN 4X4

- + Ultra-powerful & long lasting suction
- + All-terrain cleaner
- + Extra large suction capacity



REFERENCE PRICE

Standard Model

WR000161

ACCESSORIES INCLUDED IN THE PACK

Trolley	Control box	Fine Filter canister 100µ	Contact + Brushes

FOR WHICH TYPE OF POOLS?

Types of pools	Private in-ground pools and above-ground pools with rigid walls, maximum 12 x 6 m
Pool shapes	Rectangular, oval, free shape
All Floors	Flat, gentle slope, composite slope, diamond shape
Pool surfaces	Tiles, liner, polyester hull, reinforced PVC, painted concrete

DESCRIPTION

Cleaning areas	Floor / walls / waterline
Number / Length of cleaning cycles	2 cycles : - Floor only : 1h30 - Floor / walls / waterline : 2h30
Power supply	Autonomous, connected to 230V mains supply before the transformer
Steering	Pre-programmed
Drive system	4 wheel drive - 2 motors
Transmission	Gear transmission
Brushes	Yes (Contact + Brushes)
Lift System	No
Full filter indicator	Yes
Remote control	No
Safety	Deck system, out of water safety, diagnostic, electronic motor protector
Filtration system / access	Rigid Filter canister with access over the cleaner
Units / pallet	16

TECHNICAL SPECIFICATIONS

Number of motors	3
Control box supply	200-240 VAC ; 50 / 60 Hz
Power supply	30 VDC
Operating power	150 W
Cable length / Hose length	18m
Cleaner size (L x W x h)	43 x 48 x 27 cm
Packaging size (L x W x h)	56 x 56 x 46 cm
Cleaner weight	9,5 kg
Packaging weight	21 kg
Filtering surface and level	1180 cm ² / 100µ
Filtering capacity	5 L
Inlet suction size	24,5 cm

OPTIONAL ACCESSORIES (NOT INCLUDED)

Ultra-fine filter canister 60µ	Fine filter canister 100µ	Large debris filter canister 200µ	Protective cover
R0863500	R0863600	R0863700	R0568100

ELECTRIC CLEANERS

RV 5380 - VORTEX™ PRO 4WD



ULTIMATE POWER IN 4X4

- + Ultra-powerful & long lasting suction
- + All-terrain cleaner
- + Effortless removal from the water
- + Extra large suction capacity

3 YEAR
WARRANTY

PATENTED
CYCLONE
SUCTION

PATENTED
LIFT SYSTEM®



REFERENCE PRICE

Standard Model

WR000225

ACCESSORIES INCLUDED IN THE PACK



Trolley



Control box



Fine Filter canister 100µ



Contact + Brushes



Swivel

FOR WHICH TYPE OF POOLS?

Types of pools	Private in-ground pools and above-ground pools with rigid walls, maximum 12 x 6 m
Pool shapes	Rectangular, oval, free shape
All Floors	Flat, gentle slope, composite slope, diamond shape
Pool surfaces	Tiles, liner, polyester hull, reinforced PVC, painted concrete

DESCRIPTION

Cleaning areas	Floor / walls / waterline
Number / Length of cleaning cycles	2 cycles : - Floor only : 1h30 - Floor / walls / waterline : 2h30
Power supply	Autonomous, connected to 230V mains supply before the transformer
Steering	Pre-programmed
Drive system	4 wheel drive - 2 motors
Transmission	Gear transmission
Brushes	Yes (Contact + Brushes)
Lift System	Yes
Full filter indicator	Yes
Remote control	No
Safety	Deck system, out of water safety, diagnostic, electronic motor protector
Filtration system / access	Rigid Filter canister with access over the cleaner
Units / pallet	16

TECHNICAL SPECIFICATIONS

Number of motors	3
Control box supply	200-240 VAC ; 50 / 60 Hz
Power supply	30 VDC
Operating power	150 W
Cable length / Hose length	18m with Swivel
Cleaner size (L x W x h)	43 x 48 x 27 cm
Packaging size (L x W x h)	56 x 56 x 46 cm
Cleaner weight	9,5 kg
Packaging weight	21 kg
Filtering surface and level	1180 cm ² / 100µ
Filtering capacity	5 L
Inlet suction size	24,5 cm

OPTIONAL ACCESSORIES (NOT INCLUDED)

Ultra-fine filter canister 60µ	Fine filter canister 100µ	Large debris filter canister 200µ	Protective cover
R0863500	R0863600	R0863700	R0568100

ALPHA iQ™ PRO

Ultra-efficiency combined with intelligence

RA 6700 iQ model



Lift System
Lighter when removing from water

Very fine filtration 60 μ

Clear window over canister

Large suction capacity

Filter's access

4-Wheel Drive

Active brushing

SensorNavSystem™

- Smart cycle: calculates the optimal cleaning time for each pool
- Pressure sensor: provides superior wall climbing and waterline cleaning
- Water Temperature Sensor



iAquaLink[®] CONTROL

- Wi-Fi Control through iAquaLink™ App
- Remote control mode
 - 7 days timer
 - Lift System
 - Choice, start, stop and monitor the cycles
 - Smart cleaning mode
 - Display of water temperature

4 YEARS WARRANTY

3 years + 1 additional year if the robot is paired with the iAqualink™ application*

* See conditions in the warranty guide

ALPHA IQ™ PRO

Ultra-efficiency combined with intelligence



**COMPARATIVE
TABLE
OF RANGES**

TECHNICAL SPECIFICATIONS

		RA 6300 iQ	RA 6500 iQ	RA 6700 iQ	RA 6800 iQ	RA 6900 iQ
Types of pools	Surfaces	Tiles, liner, polyester hull, reinforced PVC, painted concrete	Tiles, liner, polyester hull, reinforced PVC, painted concrete	Tiles, liner, polyester hull, reinforced PVC, painted concrete	Tiles, liner, polyester hull, reinforced PVC, painted concrete	Tiles, liner, polyester hull, reinforced PVC, painted concrete
	Shapes	Rectangular, oval, free shape	Rectangular, oval, free shape	Rectangular, oval, free shape	Rectangular, oval, free shape	Rectangular, oval, free shape
	Size	12 x 6 m (18m with Swivel cable)	12 x 6 m (18m with Swivel cable)	15 x 7 m (21m with Swivel cable)	15 x 7 m (21m with Swivel cable)	20 x 10 m (25m with Swivel cable)
Performance	Traction	4 wheel drive - 2 motors	4 wheel drive - 2 motors	4 wheel drive - 2 motors	4 wheel drive - 2 motors	4 wheel drive - 2 motors
	Cleaning areas	Floor / walls / waterline	Floor / walls / waterline	Floor / walls / waterline	Floor / walls / waterline	Floor / walls / waterline
	Cyclonic Suction	✓	✓	✓	✓	✓
	Filtering level	60µ	60µ	60µ	150 and 60µ	150 and 60µ
	Filter capacity	5 L	5 L	5 L	5 L	5 L
	Swivel	✓	✓	✓	✓	✓
	Sensor Nav System™	✓	✓	✓	✓	✓
	Remote control	-	(with app)	(with app)	(with app)	(with app)
	Pressure Sensor	-	✓	✓	✓	✓
	Type of brush	Contact +	Contact +	Contact +	Contact +	Contact +
Cycles	Number of cycles	2	Multiple	Multiple	Multiple	Multiple
	Cleaning cycles	Quick floor only Smart floor/ walls / waterline (calculated time)	Quick floor only Smart floor/ walls / waterline (calculated time) Ultra floor / walls / waterline	Quick floor only Smart floor/ walls / waterline (calculated time) Ultra floor / walls / waterline Waterline only	Quick floor only Smart floor/ walls / waterline (calculated time) Ultra floor / walls / waterline Waterline only	Multiple from 0h30 to 6h with preset cycles Quick floor only Smart floor/ walls / waterline (calculated time) Ultra floor / walls / waterline Waterline only
	Manual cleaning time adjustment	-	✓	✓	✓	✓
Ease of use	iAqualink™ app control	✓	✓	✓	✓	✓
	Lift System	✓	✓	✓	✓	✓
	7-day timer	-	✓	✓	✓	✓
	Full filter indicator	✓	✓	✓	✓	✓
	Transparent window	✓	✓	✓	✓	✓
	Illuminated filter	✓	✓	✓	✓	✓
	Type of filter	Rigid Filter canister with access over the cleaner	Rigid Filter canister with access over the cleaner	Rigid Filter canister with access over the cleaner	Rigid Filter canister with access over the cleaner	Rigid Filter canister with access over the cleaner
	Trolley	✓	✓	✓	✓	✓
Advanced app features	Water temperature display	-	-	✓ (info in app)	✓ (info in app)	✓ (info in app)
	Spot cleaning mode	-	-	✓	✓	✓
	Warranty	4 years**	4 years**	4 years**	4 years**	4 years**

* 3 years + 1 year if the cleaner is paired to iAqualink™

ELECTRIC CLEANERS

RA 6300 iQ - ALPHA iQ™ PRO



ULTRA-EFFICIENCY COMBINED WITH INTELLIGENCE

- + Sensor Nav Sytem™: intelligent and personalised cleaning
- + Ultra-powerful & long lasting suction
- + Effortless removal from water
- + Wi-fi connected : intuitive interface and advanced functionalities in app from everywhere

4 YEAR WARRANTY**

Sensor Nav System™

PATENTED CYCLONE SUCTION

PATENTED LIFT SYSTEM*

SWIVEL

AquaLink CONTROL

REFERENCE PRICE

Standard Model

WR000199

ACCESSORIES INCLUDED IN THE PACK

Trolley	Control box	Ultra-Fine Filter canister 60µ	Contact + Brushes	Swivel	Free app

FOR WHICH TYPE OF POOLS?

Types of pools	Private in-ground pools and above-ground pools with rigid walls, maximum 12 x 6 m
Pool shapes	Rectangular, oval, free shape
All Floors	Flat, gentle slope, composite slope, diamond shape
Pool surfaces	Tiles, liner, polyester hull, reinforced PVC, painted concrete

DESCRIPTION

Cleaning areas	Floor / walls / waterline
Number / Length of cleaning cycles	2 cycles - Quick: floor only 1h15 - Smart: floor/ walls / waterline (calculated time)
Timer	No
Power supply	Autonomous, connected to 230V mains supply before the transformer
Steering	Pre-programmed
Drive system	4 wheel drive - 2 motors
Transmission	Gear transmission
Pressure sensor	No
Brushes	Yes (Contact + Brushes)
Lift System	Yes
Transparent window	Yes
Full filter indicator	Yes
Remote control	No
Water temperature measurement	No
Safety	Deck system, out of water safety, diagnostic, electronic motor protector
Filtration system / access	Rigid Filter canister with access over the cleaner
Units / pallet	16

TECHNICAL SPECIFICATIONS

Number of motors	3
Control box supply	200-240 VAC ; 50 / 60 Hz
Power supply	30 VDC
Operating power	150 W
Cable length / Hose length	18m with Swivel
Cleaner size (L x W x h)	43 x 48 x 27 cm
Packaging size (L x W x h)	56 x 56 x 46 cm
Cleaner weight	10 kg
Packaging weight	19,7 kg
Filtering surface and level	1180 cm ² / 60µ
Filtering capacity	5 L
Inlet suction size	24,5 cm

OPTIONAL ACCESSORIES (NOT INCLUDED)

Ultra-fine filter canister 60µ	Fine filter canister 100µ	Large debris filter canister 200µ	Protective cover
R0863500	R0863600	R0863700	R0568100

* 3 years + 1 year if the cleaner is paired to iAqualink™

ELECTRIC CLEANERS

RA 6500 iQ - ALPHA iQ™ PRO



4 YEAR
WARRANTY**

Sensor
Nav
System™

PATENTED
CYCLONE
SUCTION

PATENTED
LIFT SYSTEM®

SWIVEL

AquaLink
CONTROL

ULTRA-EFFICIENCY COMBINED WITH INTELLIGENCE

- + Sensor Nav Sytem™: intelligent and personalised cleaning
- + Ultra-powerful & long lasting suction
- + Effortless removal from water
- + Wi-fi connected : intuitive interface and advanced functionalities in app from everywhere

REFERENCE PRICE

Standard Model	WR000198
----------------	----------

ACCESSORIES INCLUDED IN THE PACK

Trolley	Control box	Ultra-Fine Filter canister 60µ	Contact + Brushes	Swivel	Free app

FOR WHICH TYPE OF POOLS?

Types of pools	Private in-ground pools and above-ground pools with rigid walls, maximum 12 x 6 m
Pool shapes	Rectangular, oval, free shape
All Floors	Flat, gentle slope, composite slope, diamond shape
Pool surfaces	Tiles, liner, polyester hull, reinforced PVC, painted concrete

DESCRIPTION

Cleaning areas	Floor / walls / waterline
Number / Length of cleaning cycles	Multiple from 0h30 to 3h30 with preset cycles: - Quick: floor only 1h15 - Smart: floor/ walls / waterline (calculated time) - Ultra: floor / walls / waterline (2h45)
Timer	7-days
Power supply	Autonomous, connected to 230V mains supply before the transformer
Steering	Pre-programmed
Drive system	4 wheel drive - 2 motors
Transmission	Gear transmission
Pressure sensor	Yes
Brushes	Yes (Contact + Brushes)
Lift System	Yes
Transparent window	Yes
Full filter indicator	Yes
Remote control	Remote control mode (with app)
Water temperature measurement	No
Safety	Deck system, out of water safety, diagnostic, electronic motor protector
Filtration system / access	Rigid Filter canister with access over the cleaner
Units / pallet	16

TECHNICAL SPECIFICATIONS

Number of motors	3
Control box supply	200-240 VAC ; 50 / 60 Hz
Power supply	30 VDC
Operating power	150 W
Cable length / Hose length	18m with Swivel
Cleaner size (L x W x h)	43 x 48 x 27 cm
Packaging size (L x W x h)	56 x 56 x 46 cm
Cleaner weight	10 kg
Packaging weight	19,9 kg
Filtering surface and level	1180 cm ² / 60µ
Filtering capacity	5 L
Inlet suction size	24,5 cm

OPTIONAL ACCESSORIES (NOT INCLUDED)

Ultra-fine filter canister 60µ	Fine filter canister 100µ	Large debris filter canister 200µ	Protective cover
R0863500	R0863600	R0863700	R0568100

* 3 years + 1 year if the cleaner is paired to iAqualink™

ELECTRIC CLEANERS

RA 6700 iQ - ALPHA iQ™ PRO



4
YEAR
WARRANTY**

Sensor
Nav
System™

PATENTED
CYCLONE
SUCTION

PATENTED
LIFT SYSTEM*

SWIVEL

AquaLink
CONTROL

REFERENCE PRICE

Standard Model

WR000197

ACCESSORIES INCLUDED IN THE PACK

Trolley	Control box	Ultra-Fine Filter canister 60µ	Contact + Brushes	Swivel	Free app

FOR WHICH TYPE OF POOLS?

Types of pools	Private in-ground pools and above-ground pools with rigid walls, maximum 15 x 7 m
Pool shapes	Rectangular, oval, free shape
All Floors	Flat, gentle slope, composite slope, diamond shape
Pool surfaces	Tiles, liner, polyester hull, reinforced PVC, painted concrete

DESCRIPTION

Cleaning areas	Floor / walls / waterline
Number / Length of cleaning cycles	Multiple from 0h30 to 3h30 with preset cycles: - Quick: floor only 1h15 - Smart: floor/ walls / waterline (calculated time) - Ultra: floor / walls / waterline (2h45) - Waterline only: 0h45
Timer	7-days
Power supply	Autonomous, connected to 230V mains supply before the transformer
Steering	Pre-programmed
Drive system	4 wheel drive - 2 motors
Transmission	Gear transmission
Pressure sensor	Yes
Brushes	Yes (Contact + Brushes)
Lift System	Yes
Transparent window	Yes
Full filter indicator	Yes
Remote control	Remote control mode (with app)
Water temperature measurement	Yes (info in app)
Safety	Deck system, out of water safety, diagnostic, electronic motor protector
Filtration system / access	Rigid Filter canister with access over the cleaner
Units / pallet	16

TECHNICAL SPECIFICATIONS

Number of motors	3
Control box supply	200-240 VAC ; 50 / 60 Hz
Power supply	30 VDC
Operating power	150 W
Cable length / Hose length	21m with Swivel
Cleaner size (L x W x h)	43 x 48 x 27 cm
Packaging size (L x W x h)	56 x 56 x 46 cm
Cleaner weight	10 kg
Packaging weight	20,2 kg
Filtering surface and level	1180 cm ² / 60µ
Filtering capacity	5 L
Inlet suction size	24,5 cm

OPTIONAL ACCESSORIES (NOT INCLUDED)

Ultra-fine filter canister 60µ	Fine filter canister 100µ	Large debris filter canister 200µ	Protective cover
R0863500	R0863600	R0863700	R0568100

* 3 years + 1 year if the cleaner is paired to iAqualink™

ELECTRIC CLEANERS

RA 6800 iQ - ALPHA iQ™ PRO



4
YEAR
WARRANTY**



ULTRA-EFFICIENCY COMBINED WITH INTELLIGENCE

- + Sensor Nav Sytem™: intelligent and personalised cleaning
- + Ultra-powerful & long lasting suction
- + Dual-Stage filtration
- + Effortless removal from water
- + Wi-fi connected : intuitive interface and advanced functionalities in app from everywhere

REFERENCE PRICE

Standard Model	WR000295
----------------	----------

ACCESSORIES INCLUDED IN THE PACK

Trolley	Control box	Dual-Stage filter 150 + 60µ (with possibility to use 150µ alone)	Contact + Brushes	Swivel	Free app

FOR WHICH TYPE OF POOLS?

Types of pools	Private in-ground pools and above-ground pools with rigid walls, maximum 15 x 7 m
Pool shapes	Rectangular, oval, free shape
All Floors	Flat, gentle slope, composite slope, diamond shape
Pool surfaces	Tiles, liner, polyester hull, reinforced PVC, painted concrete

DESCRIPTION

Cleaning areas	Floor / walls / waterline
Number / Length of cleaning cycles	Multiple from 0h30 to 3h30 with preset cycles: - Quick: floor only 1h15 - Smart: floor/ walls / waterline (calculated time) - Ultra: floor / walls / waterline (2h45) - Waterline only: 0h45
Timer	7-days
Power supply	Autonomous, connected to 230V mains supply before the transformer
Steering	Pre-programmed
Drive system	4 wheel drive - 2 motors
Transmission	Gear transmission
Pressure sensor	Yes
Brushes	Yes (Contact + Brushes)
Lift System	Yes
Transparent window	Yes
Full filter indicator	Yes
Remote control	Remote control mode (with app)
Water temperature measurement	Yes (info in app)
Safety	Deck system, out of water safety, diagnostic, electronic motor protector
Filtration system / access	Rigid Filter canister with access over the cleaner
Units / pallet	16

TECHNICAL SPECIFICATIONS

Number of motors	3
Control box supply	200-240 VAC ; 50 / 60 Hz
Power supply	30 VDC
Operating power	150 W
Cable length / Hose length	21m with Swivel
Cleaner size (L x W x h)	43 x 48 x 27 cm
Packaging size (L x W x h)	56 x 56 x 46 cm
Cleaner weight	10 kg
Packaging weight	20,5 kg
Filtering surface and level	1827 cm ² / 150 and 60µ
Filtering capacity	5 L
Inlet suction size	24,5 cm

OPTIONAL ACCESSORIES (NOT INCLUDED)

Coarse filter 150µ for stand alone or Dual-Stage use	Ultra-fine filter 60µ for Dual-Stage use	Fine filter canister 100µ	Large debris filter canister 200µ	Ultra-fine filter canister 60µ	Protective cover
R0913300	R0913400	R0863600	R0863700	R0863500	R0568100

** 3 years + 1 year if the cleaner is paired to iAqualink™



ELECTRIC CLEANERS

RA 6900 iQ - ALPHA iQ™ PRO



ULTRA-EFFICIENCY COMBINED WITH INTELLIGENCE

- + Sensor Nav Sytem™: intelligent and personalised cleaning
- + Ultra-powerful & long lasting suction
- + Dual-Stage filtration
- + Effortless removal from water
- + Wi-fi connected : intuitive interface and advanced functionalities in app from everywhere

4 YEAR WARRANTY**



REFERENCE PRICE

Standard Model	WR000296
----------------	----------

ACCESSORIES INCLUDED IN THE PACK

Trolley	Control box	Dual-Stage filter 150 + 60µ (with possibility to use 150µ alone)	Contact + Brushes	Swivel	Free app

FOR WHICH TYPE OF POOLS?

Types of pools	Private in-ground pools and above-ground pools with rigid walls, maximum 20 x 10 m
Pool shapes	Rectangular, oval, free shape
All Floors	Flat, gentle slope, composite slope, diamond shape
Pool surfaces	Tiles, liner, polyester hull, reinforced PVC, painted concrete

DESCRIPTION

Cleaning areas	Floor / walls / waterline
Number / Length of cleaning cycles	Multiple from 0h30 to 6h with preset cycles: - Quick: floor only 1h15 - Smart: floor/ walls / waterline (calculated time) - Ultra: floor / walls / waterline (2h45) - Waterline only: 0h45
Timer	7-days
Power supply	Autonomous, connected to 230V mains supply before the transformer
Steering	Pre-programmed
Drive system	4 wheel drive - 2 motors
Transmission	Gear transmission
Pressure sensor	Yes
Brushes	Yes (Contact + Brushes)
Lift System	Yes
Transparent window	Yes
Full filter indicator	Yes
Remote control	Remote control mode (with app)
Water temperature measurement	Yes (info in app)
Safety	Deck system, out of water safety, diagnostic, electronic motor protector
Filtration system / access	Rigid Filter canister with access over the cleaner
Units / pallet	16

TECHNICAL SPECIFICATIONS

Number of motors	3
Control box supply	200-240 VAC ; 50 / 60 Hz
Power supply	30 VDC
Operating power	150 W
Cable length / Hose length	25m with Swivel
Cleaner size (L x W x h)	43 x 48 x 27 cm
Packaging size (L x W x h)	56 x 56 x 46 cm
Cleaner weight	10 kg
Packaging weight	20,9 kg
Filtering surface and level	1827 cm ² / 150 and 60µ
Filtering capacity	5 L
Inlet suction size	24,5 cm

OPTIONAL ACCESSORIES (NOT INCLUDED)

Coarse filter 150µ for stand alone or Dual-Stage use	Ultra-fine filter 60µ for Dual-Stage use	Fine filter canister 100µ	Large debris filter canister 200µ	Ultra-fine filter canister 60µ	Protective cover
R0913300	R0913400	R0863600	R0863700	R0863500	R0568100

* 3 years + 1 year if the cleaner is paired to iAqualink™

DIAGNOSTIC TOOLS

DIAG BOX

- + Simple system with display for off-line use (without a PC)
- + Possible out-of-water testing in off-line mode
- + Can be connected to a PC for full diagnostic check
- + Multiple light panel provided with colour coding for all products



WHICH PRODUCTS?

All Vortex™ products (including Vortex™1) All Tornax™
All CyclonX™ products
Lazernaut NT, Cybernaut™ NT (2010 ONWARDS)







TESTED ELEMENTS?

In off-line mode: box/motor block/cable/remote control

Voyager/XA Type/CNX, Alpha iQ platforms cannot be diagnose with the Diag Box.
The diagnostic must be performed with its own control box (by entering in Diagnostic mode. See details in the technical procedure or with an Alpha iQ control box which diag Alpha iQ & Voyager/XA Type/CNX models too).

PRODUCT REFERENCE

Product reference: R0685300

Robot type	Elements to be tested	Type of cable to be connected
CyclonX™	Robot	GREY adapter 
	Control unit	BLUE adapter 
Vortex™ Tornax	Motor block	BROWN adapter 
	Robot	Robot floating cable 
Vortex™ 1	Control unit	GREEN adapter 
	Robot	RED adapter 
Lazernaut, Cybernaut™ NT (>2010)	Robot (via robot control unit)	YELLOW adapter 



DIAG CABLE MOTOR BLOCK FOR SELF-DIAGNOSABLE PLATFORMS

WHICH PRODUCTS?

Brown adapter (identical to the one supplied in the Diag box) to diagnose the motor block of models of Alpha iQ™ range by connecting the motor **directly to the control box of the cleaner.**



PRODUCT REFERENCE

Product reference: R0616900

WHICH PRODUCTS?

White adaptator (identical to the one supplied in the Diag box) to diagnose the motor block of models of Voyager/XA Type/CNX ranges by connecting the motor directly to the control box of the cleaner





PRODUCT REFERENCE

Product reference: R0616900

HYDRAULIC CLEANERS

A simple and affordable solution

COMPARATIVE TABLE OF RANGES

	T3®	T5® Duo	MX6®	MX8®	MX9®
					
Pool Dimension max.	9 x 5 m	12 x 6 m	10 x 5 m	12 x 6 m	12 x 6 m
Number of pipes 1 m - Twist Lock pipe	10	12	10	12	12
Motion	Diaphragm	Diaphragm	Mechanical	Mechanical	Mechanical
Suction	-	-	1 turbine	2 turbines	2 turbines with brushes
Pool floors					
Rectangular	•	•	•	•	•
Oval	•	•	•	•	•
Round	•	•	•	•	•
Free shape		•	•	•	•
Floor only	•				
Floor and walls		•	•	•	•
Flat	•	•	•	•	•
Gentle slope	•	•	•	•	•
Composit slope		•	•	•	•
Diamond shape				•	•
Minimum power required from the filtration pump	1/2 HP	3/4HP	3/4 HP*	3/4 HP*	3/4 HP*
Warranty	2 years	2 years	2 years	2 years	2 years

* 1 HP needed for tile pools

STANDARD INSTALLATION

- The suction cleaner is connected directly to the vacuum point or skimmer. No electrical connection required.

- The ideal hose length for the pool equals the greatest distance that the cleaner can cover in the pool from the connection point (skimmer) to the farthest corner of the pool, plus a 1 metre section.

- For optimal installation, perform a flow test and adjust the flow rate using an adjusting valve.

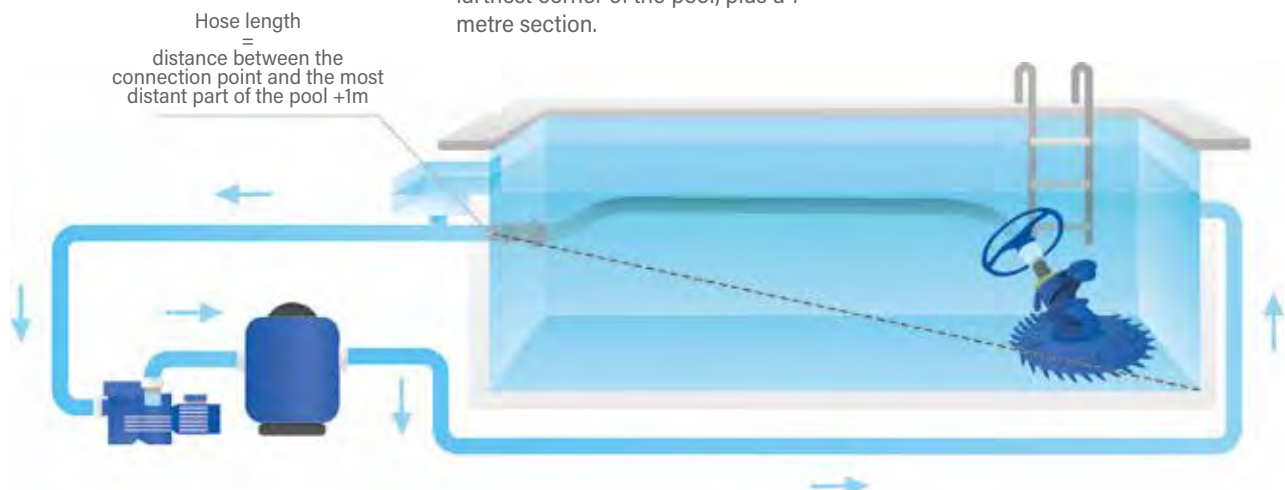

HYDRAULIC CLEANERS

T3™



- + DiaCyclone Diaphragm: even more powerful suction
- + Finned disc: optimum mobility of the cleaner



REFERENCE PRICE

Standard Model	W70674
----------------	--------

ACCESSORIES INCLUDED IN THE PACK

Twist Lock Hoses	Wheel deflector	Flow gauge	Flowkeeper valve (skimmer)

FOR WHICH TYPE OF POOLS?

Types of pools	Private in-ground pools and above-ground pools with rigid walls, maximum 9 x 5 m
Pool shapes	Rectangular, oval
All Floors	Flat, gentle slope
Pool surfaces	Tiles, liner, polyester hull, reinforced PVC, painted concrete

DESCRIPTION

Cleaning areas	Floor
Cleaning cycles	Recommended 6h filtering in three 2h sessions
Power supply	Filtering group
Steering	Random
Filtration system / access	Suction line or skimmer
Suction	DiaCyclone Diaphragm
Debris collection	Fine and medium
Units / pallet	27

TECHNICAL SPECIFICATIONS

Cable length / Hose length	10 sections of 1 m
Cleaner size (L x W x h)	41 x 36 x 28 cm
Packaging size (L x W x h)	102,8 x 41,5 x 22,4 cm
Cleaner weight	1,2 kg
Packaging weight	6,8 kg
Filtration surface and level	Pool filtering circuit
Inlet suction size	30 cm
Displacement speed	6,5 m/min
Minimum required filter pump power	1/2 HP

OPTIONAL ACCESSORIES (NOT INCLUDED)

6 section of 1m Twist Lock hoses

W78055

HYDRAULIC CLEANERS

T5™ Duo



- + DiaCyclone Diaphragm: even more powerful suction
- + Flexible Duo Traction Control disc in 2 parts: optimum grip

2 YEAR
WARRANTY

ALL TYPES OF
SWIMMING POOLS

ALL TYPE OF
LININGS

REFERENCE PRICE

Standard Model

W78046

ACCESSORIES INCLUDED IN THE PACK

Twist Lock Hoses	Wheel deflector	Flow gauge	Flowkeeper valve (skimmer)

FOR WHICH TYPE OF POOLS?

Types of pools	Private in-ground pools and above-ground pools with rigid walls, maximum 12 x 6 m
Pool shapes	Rectangular, oval, free shape
All Floors	Flat, gentle slope, composite slope
Pool surfaces	Tiles, liner, polyester hull, reinforced PVC, painted concrete

DESCRIPTION

Cleaning areas	Floor and walls
Cleaning cycles	Recommended 6h filtering in three 2h sessions
Power supply	Filtering group
Steering	Random
Filtration system / access	Suction line or skimmer
Suction	DiaCyclone Diaphragm
Debris collection	Fine and medium
Units / pallet	24

TECHNICAL SPECIFICATIONS

Cable length / Hose length	12 sections of 1 m
Cleaner size (L x W x h)	44 x 43 x 22 cm
Packaging size (L x W x h)	99 x 45,5 x 29,5 cm
Cleaner weight	1,4 kg
Packaging weight	8,4 kg
Filtering surface and level	Pool filtering circuit
Inlet suction size	44 cm
Displacement speed	6 m/min
Minimum required filter pump power	3/4 HP

OPTIONAL ACCESSORIES (NOT INCLUDED)

6 section of 1m Twist Lock hoses	Cyclonic™ Leaf Catcher
W78055	W37110

HYDRAULIC CLEANERS

MX6™



- + Pre-programmed X-Drive navigation system : methodical cleaning of all areas
- + Turbo aspiration: a powerful turbine and one peripheral propeller
- + Traction using notched tracks: for perfect stability and total movement
- + Equipped with a flow regulator valve: automatically controls excess flow through cleaner for best performance and longevity



REFERENCE PRICE

Standard Model	W79102
----------------	--------

ACCESSORIES INCLUDED IN THE PACK

Twist Lock Hoses	In-ground valve cuff	45° Elbow extended	45° Elbow	Flow Regulator Valve (cleaner)	Flowkeeper valve (skimmer)

FOR WHICH TYPE OF POOLS?

Types of pools	Private in-ground pools and above-ground pools with rigid walls, maximum 10 x 5 m
Pool shapes	Rectangular, oval, free shape
All Floors	Flat, gentle slope, composite slope
Pool surfaces	Tiles, liner, polyester hull, reinforced PVC, painted concrete

DESCRIPTION

Cleaning areas	Floor and walls
Cleaning cycles	Recommended 6h filtering in three 2h sessions
Power supply	Filtering group
Steering	Random
Filtration system / access	Suction line or skimmer
Suction	Mechanical suction : turbine
Debris collection	Fine and medium
Units / pallet	30

TECHNICAL SPECIFICATIONS

Cable length / Hose length	10 sections of 1 m
Cleaner size (L x W x h)	31 x 19 x 22 cm
Packaging size (L x W x h)	102 x 23 x 37 cm
Cleaner weight	2,5 kg
Packaging weight	8,2 kg
Filtering surface and level	Pool filtering circuit
Inlet suction size	25 cm
Displacement speed	8 m/min
Minimum required filter pump power	3/4 HP (1 HP for Tile pools)

OPTIONAL ACCESSORIES (NOT INCLUDED)

6 section of 1m Twist Lock hoses	Cyclonic™ Leaf Catcher
W78055	W37110

HYDRAULIC CLEANERS

MX9™



- + Pre-programmed X-Drive navigation system : methodical cleaning of all areas
- + Turbo aspiration: a powerful turbine and two peripheral propellers with brushes
- + Exclusive cleaning mode thanks to scrubbing brushes
- + Traction using notched tracks: for perfect stability and total movement
- + Twist Lock Hoses : easy and safe connection



REFERENCE PRICE

Standard Model

WS000033

ACCESSORIES INCLUDED IN THE PACK

Cyclonic scrubbing brushes	Twist Lock Hoses	In-ground valve cuff	45° Elbow extended	45° Elbow	Flow Regulator Valve (cleaner)	Flowkeeper valve (skimmer)

FOR WHICH TYPE OF POOLS?

Types of pools	Private in-ground pools and above-ground pools with rigid walls, maximum 12 x 6 m
Pool shapes	Rectangular, oval, free shape
All Floors	Flat, gentle slope, composite slope
Pool surfaces	Tiles, liner, polyester hull, reinforced PVC, painted concrete

DESCRIPTION

Cleaning areas	Floor and walls
Cleaning cycles	Recommended 6h filtering in three 2h sessions
Power supply	Filtering group
Steering	Random
Filtration system / access	Suction line or skimmer
Suction	Mechanical suction : turbine
Debris collection	Fine and medium
Units / pallet	30

TECHNICAL SPECIFICATIONS

Cable length / Hose length	12 sections of 1 m
Cleaner size (L x W x h)	41 x 19 x 22 cm
Packaging size (L x W x h)	102 x 23 x 37 cm
Cleaner weight	3,2 kg
Packaging weight	9,5 kg
Filtering surface and level	Pool filtering circuit
Inlet suction size	36cm
Displacement speed	8 m/min
Minimum required filter pump power	3/4 HP (1 HP for Tile pools)

OPTIONAL ACCESSORIES (NOT INCLUDED)

6 section of 1m Twist Lock hoses	Cyclonic™ Leaf Catcher
W78055	W37110

HYDRAULIC CLEANERS

Cyclonic™ Leaf Catcher



- + Cyclone suction system: constant suction and dirt remains in suspension
- + no pressure on the pump
- + Large, transparent, easy-to-empty filter basket
- + Fits all hose types

2 YEAR WARRANTY

REFERENCE PRICE

Standard Model	W37110
----------------	--------

ACCESSORIES INCLUDED IN THE PACK



Standard hose and Twist Lock hose adaptors

DESCRIPTION		TECHNICAL SPECIFICATIONS	
Filtration system / access	Suction line or skimmer	Cleaner size (L x W x h)	23 x 19 x 28 cm
Debris collection	All debris	Packaging size (L x W x h)	24 x 20 x 29 cm
		Cleaner weight	1 kg
		Packaging weight	1,3 kg

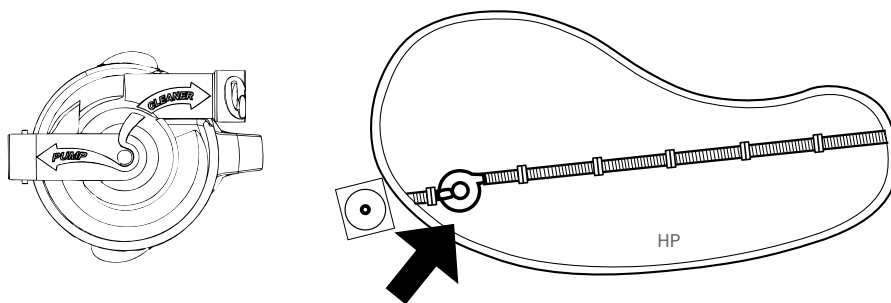

Install at the first hose connection closest to skimmer/or suction line.
Ensure correct orientation using guides (Pump/Cleaner) on Leaf Catcher lid.

HYDRAULIC CLEANERS

Spa Wand



- + Targeted cleaning of small volumes : spa, steps...
- + Efficient and easy to use handheld brush and no connection required
- + Debris are collected in a separate stainless steel filter

2 YEAR WARRANTY

ALL TYPES OF SWIMMING POOLS

ALL TYPE OF LININGS

REFERENCE PRICE

Standard Model

W9320018

ACCESSORIES INCLUDED IN THE PACK



Steel filter



2 sweeping nozzles



Wall bracket

FOR WHICH TYPE OF POOLS?

Types of pools	Private above ground and above-ground pools with rigid walls, spas, steps, overflow gutters, integrated filtering blocks
Pool shapes	Rectangular, oval, free shape
All Floors	Flat, gentle slope, composite slope
Pool surfaces	Tiles, liner, polyester hull, reinforced PVC, painted concrete

DESCRIPTION

Power supply	Manual brush
Filtration system / access	Suction line or skimmer
Debris collection	Dust, insects, gravel, leaves, ...

TECHNICAL SPECIFICATIONS

Cleaner size (L x W x h)	7 x 7 x 144 cm
Packaging size (L x W x h)	8 x 9 x 146 cm
Cleaner weight	1,2 kg
Packaging weight	1,7 kg

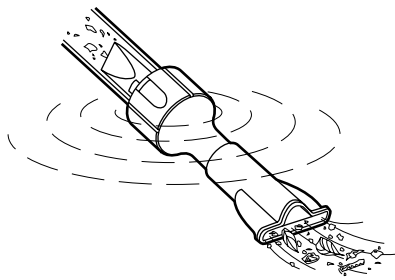

Wide sweeping nozzle: specially designed for surface floating debris or suspended debris.



Double function nozzle: specially designed for debris at the bottom and corners.





The high pressure cleaner

The cleaner sucks in debris using a physical principle called '**Venturi effect**', which is produced inside the machine and **converts the incoming water into a powerful suction current**.

This characteristic provides maximum efficiency in the minimum time.

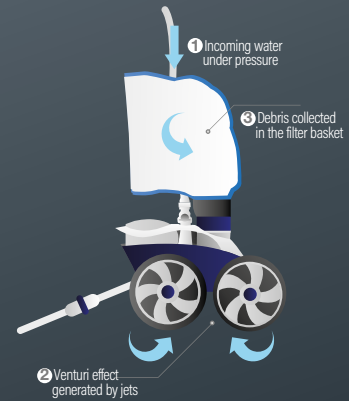

EQUIPMENT NEEDED

- The pipes of the vacuum point must be made of RIGID 16 bar PVC and not flexible material
- Booster, minimum 1 HP coupled to filtration

For optimum operation, advise your customers to equip their pools with an electrical programming box and a Polaris® booster. This guarantees complete compatibility and ideal suction power.

- Minimum operating pressure 1.8 bar

STANDARD INSTALLATION

- 1 Water is sucked by the pump through the skimmers and the floor drain.
- 2 The water is sent to the filter to be cleaned.
- 3 The water is returned clean to the swimming pool through the return discharges.
- 4 A detour is created on this pipework to feed the booster.
- 5 Polaris® pressure cleaners are connected to the vacuum point converted into return discharge.
- 6 The Venturi effect generated by the jets converts the incoming water into a powerful suction current and enables the cleaner to move.
- 7 The length of the pipe must be equal to the distance between the return pipe (5) and the furthest point (7).

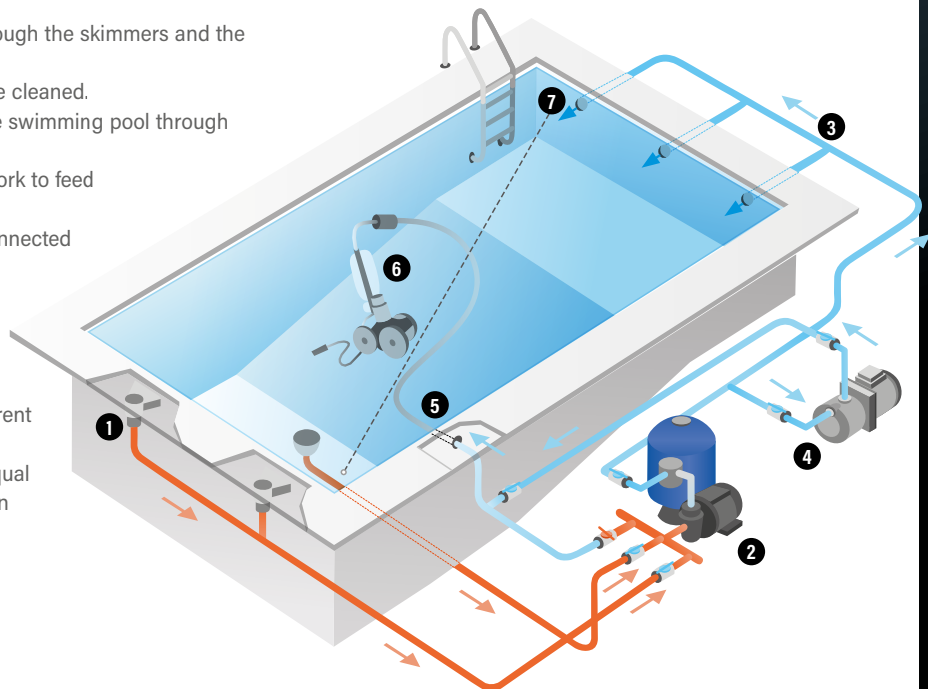

INSTALLATION OF THE PIPE

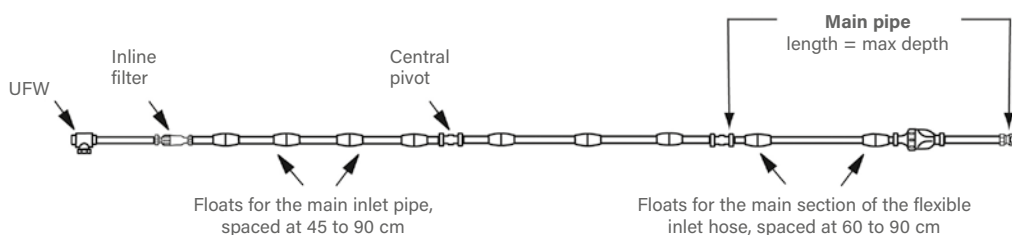



PRESSURE CLEANER

Polaris 280

- + 2 jets, ultra-powerful suction
- + Wide suction aperture
- + Automatic back-up valve, anti-jamming.

2 YEAR WARRANTY



REFERENCE PRICE

Standard Model

W7220000

ACCESSORIES INCLUDED IN THE PACK

	
standard sand/silt bag	Back-up valve

FOR WHICH TYPE OF POOLS?

Types of pools	Private in-ground pools
Pool shapes	All shapes
All Floors	Flat bottom, gentle slope, composed slope, diving pit, diamond point
Pool surfaces	Liner

DESCRIPTION	
System type	Pressure cleaner
Steering	Random and automatic reverse
Power supply	Booster pump coupled to filtering
Suction	2 jets Venturi system
Debris collection	Filter bag + sweep hose scrubber

TECHNICAL SPECIFICATIONS	
Required equipment*	1 HP booster pump
Operating pressure	2,2 bars
Specific brush socket line	Fixed hose 16 bars
Speed	15 m / min
Suction size	7 cm
Hose length	9,60 m
Weight	3,2 kg
Units / pallet	36

OPTIONAL ACCESSORIES (NOT INCLUDED)

	Disposable bags (EZ Bag) (packs of 6)	Standard silt bag	Leaf bag	Ultra fine bag
Ref. Polaris	K-52	K-13	K-15	K-14
Ref. Zodiac	W7230114	W7230102	W7230104	W7230103

*Depending on the distance to the technical room



PRESSURE CLEANER

3900 SPORT

- + 3 jets, ultra-powerful suction
- + 3 wheel drive fitted with wide tyres
- + Automatic back-up valve, anti-jamming
- + Stainless steel chain, highly reliable gear system.

2 YEAR WARRANTY



ALL TYPES OF SWIMMING POOLS

REFERENCE PRICE

Standard Model	W7620000
----------------	----------

ACCESSORIES INCLUDED IN THE PACK

Double capacity filter bag	Ultra-fine filter bag	Back-up valve	Tail Sweep Pro

FOR WHICH TYPE OF POOLS?

Types of pools	Private in-ground pools
Pool shapes	All shapes
All Floors	Flat bottom, gentle slope, composed slope, diving pit, diamond point
Pool surfaces	Liner

DESCRIPTION

System type	Pressure cleaner
Steering	Random and automatic reverse
Power supply	Booster pump coupled to filtering
Suction	3 jets Venturi system
Debris collection	Filter bag + sweep hose scrubber

TECHNICAL SPECIFICATIONS

Required equipment*	1 HP booster pump, 1.5 HP booster pump and greater **
Operating pressure	2,2 to 2,6 bars max
Specific brush socket line	Fixed hose 16 bars
Speed	20 m / min
Suction size	6 cm
Hose length	9,60 m
Weight	3,5 kg
Units / pallet	16

OPTIONAL ACCESSORIES (NOT INCLUDED)

	Disposable bags (EZ Bag) (packs of 6)	Standard, double capacity silt bag	Standard silt bag	Leaf bag	Ultra fine bag
Ref. Polaris	K-52	39-310	K-23	K-15	K-18
Ref. Zodiac	W7230114	W7610000	W7230111	W7230104	W7230109

*Depending on the distance to the technical room

**For a technical room at a distance of more than 15 m. For a perfect use of your pressure cleaner, we recommend to use it with a 1.5 HP booster pump and greater

Polaris QUATTROTM SPORT

> DEBRIS DOESN'T STAND A CHANCE



Large capacity and easy-clean debris canister

Can easily be removed and cleaned without touching the debris with a simple jet of water.

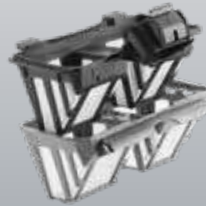

Double filtration

Collects both large and fine debris.

Active brushing

Removes debris, even stuck-on debris.



Extra-large debris intake & superior vacuum power

Easily sucks up all types of debris, even the largest.



Monte aux parois

Ses 4 roues motrices lui confèrent une grande agilité pour nettoyer le fond mais aussi les parois.



Multi-directional navigation

Delivers quick and efficient coverage of the entire pool.

Powered with a booster bump



PRESSURE CLEANER

Polaris QUATTRO™ SPORT

- + 3 jets, ultra-powerful suction
- + Large debris intake
- + Multi-directional navigation
- + Dual-stage filtration



2 YEAR
WARRANTY



REFERENCE PRICE

Standard Model

WE000028

ACCESSORIES INCLUDED IN THE PACK



Dual stage filter canister 3.5L

FOR WHICH TYPE OF POOLS?

Types of pools	Private in-ground pools
Pool shapes	All shapes
All Floors	Flat bottom, gentle slope, composed slope, diving pit, diamond point
Pool surfaces	Liner, polyester hull, reinforced PVC, painted concrete*

DESCRIPTION	
System type	Pressure cleaner
Steering	Random and multi-directional
Power supply	Booster pump coupled to filtering
Suction	3 jets Venturi system
Debris collection	Rigid dual canister / access over the cleaner

TECHNICAL SPECIFICATIONS	
Required equipment*	1 HP booster pump, 1.5 HP booster pump and greater **
Operating pressure	2,2 bars
Specific brush socket line	Fixed hose 16 bars
Speed	16 m / min
Suction size	7 cm
Hose length	9,60 m
Weight	6.8 kg
Units / pallet	20

OPTIONAL ACCESSORIES (NOT INCLUDED)

	All-purpose filter canister	Fine filter canister
Ref. Polaris	-	-
Ref. Zodiac	R0836300	R0836400

* For better grip of your cleaner on slippery surfaces, replace the 2 original rear tires with Positrax tires
 ** For a technical room at a distance of more than 15 m. For a perfect use of your pressure cleaner, we recommend to use it with a 1.5 HP

PRESSURE CLEANER

Polaris TailSweep PRO



- + Optimized removal of debris in the pool
- + Reduced water spraying around the pool
- + Easy to install at the end of the flexible hose of Polaris® robot cleaners
- + Suitable for all models of Polaris® pressure cleaners



2 YEAR WARRANTY



ALL TYPES OF SWIMMING POOLS

	18 units Display	Case of 12 units
REFERENCE PRICE		
Standard Model	W7220031	W7220032



ACCESSORIES INCLUDED IN THE PACK

	
Foam brush	Tail sweep

TECHNICAL SPECIFICATIONS

Dimensions of the accessory (L x D x h)	10 x 5 x 5 cm
Packaging dimensions (L x D x h)	11 x 5 x 5 cm
Weight of the accessory	21 g
Packaged weight	39 g

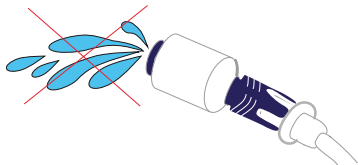
GENERAL SPECIFICATIONS

Installation	By the user, on the end of the flexible hose of the pressure cleaner	
	Side inlets for water suction or air suction	Diffuser for water dispersion
<p>In the water :</p> <p>The Trail Sweep Pro® side inlets are used to suck in the water which is re-injected by Venturi effect into the diffuser :</p> <ul style="list-style-type: none"> • Increased flow rate • Optimised removal of debris 		
	<p>Out of the water :</p> <p>As soon as these inlets emerge from the water, the air which is sucked in cuts the injection of water to avoid water being sprayed outside the pool.</p>	

PRESSURE CLEANER



Booster Pump & Control box

- + All water treatment adapted (sea water, chlorine water, demineralized water...)
- + Distance from the pool up to 20 meters
- + Connection kit "Quick Connect" included in the BPK pack



	Booster pump without connexion kit	Booster pump with connexion kit
REFERENCE PRICE		
Standard Model	BP / W4530247	BPK / W4530248

GENERAL	
Power	1 CV single phase
Type	Multicellular
Body and turbine	Noryl®
Composition	Pump + Kit Quick Connect (BPK)
Weight	11 kg
Guarantee	2 ans

TECHNICAL SPECIFICATIONS	
Supply voltage	220-240 V
Consumption	0,75 kW
Turbine shaft	Inox AISI 420
RPM	2800 rpm
Bust of AMP	5,3 A
Protection index	Watertightness IP-55

- + Ideal to be combined with Polaris Cleaners
- + Easy to program
- + Magnetic-thermal breaker to protect the system



	Electric box
REFERENCE PRICE	
Standard Model	045550POLARIS

GENERAL	
Size	L. 220 x l. 200 x H. 200 mm
Weight	1 kg
Guarantee	2 ans

TECHNICAL SPECIFICATIONS	
Electrical supply	1 ph 230 V / 50 Hz
Circuit breaker	4 to 6,3 A
Switch main power	Auto / stop / manual
Protection index	Watertightness IP-65
Installation	30 mA

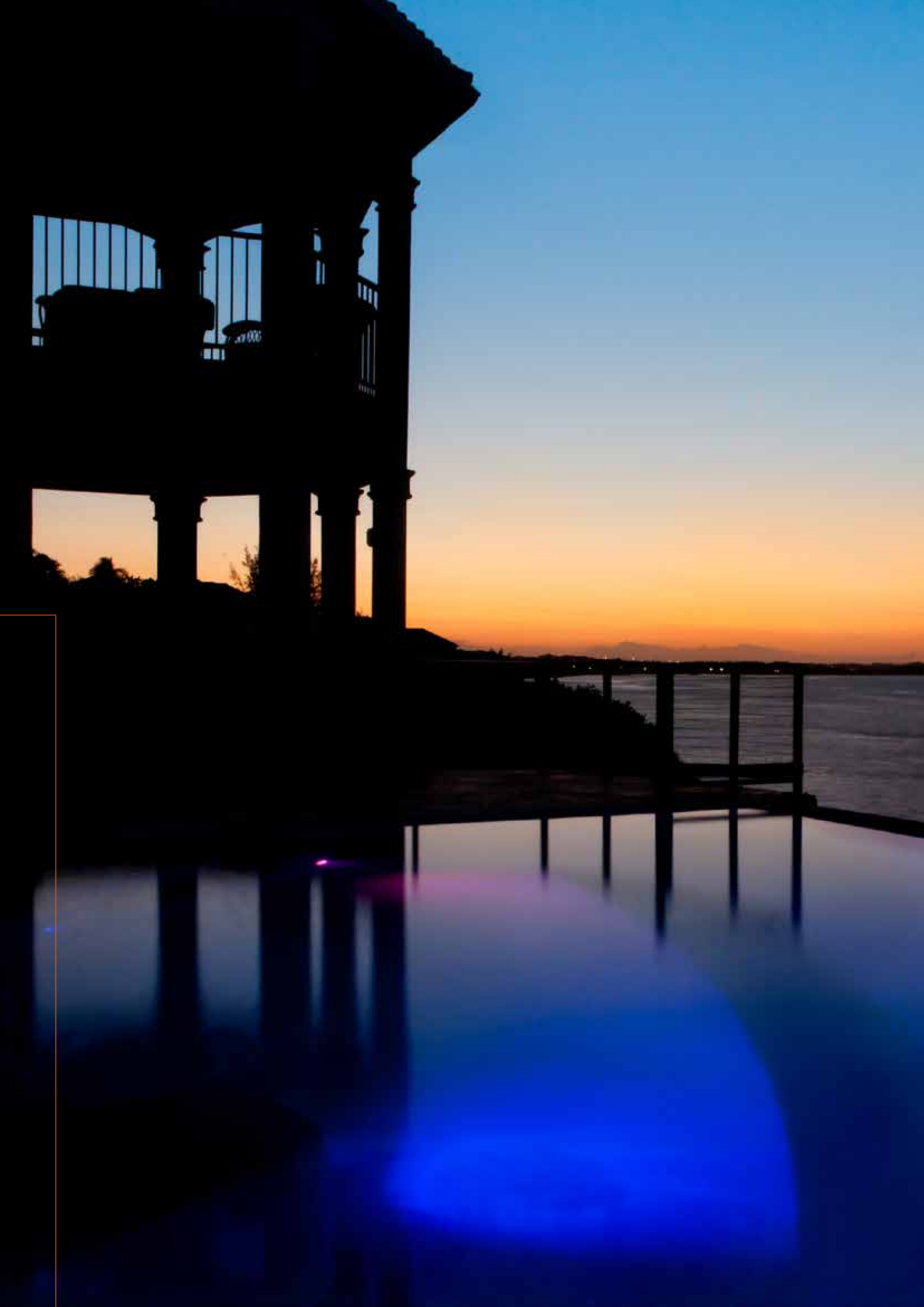

COMMERCIAL POOLS

CLEANING



912 AUTOMATIC COMMERCIAL POOL CLEANERS

- 912 Vortrax TRX 7500 iQ
- 913 Vortrax TRX 7700 iQ
- 914 Arco
- 915 Arcomax

PUBLIC POOL CLEANERS

TRX 7500 iQ - VORTRAX



SPECIFICALLY DESIGNED FOR INTENSIVE USE IN SMALL TO MEDIUM PUBLIC POOLS. TOUGH, SMART AND ULTRA-EFFICIENT

- + Sensor Nav Sytem™: intelligent and personalised cleaning with anti-tangle compass system without the need of swivel
- + New Heavy-duty materials and traction system for intensive use
- + Ultra-powerful & long lasting suction
- + Designed for a professional use in public swimming pools for hotels, campsites and sports centers



REFERENCE PRICE

Standard Model	WR000413
----------------	----------



ACCESSORIES INCLUDED IN THE PACK

- Trolley
- Control box
- Dual-Stage filter 150 + 60µ (with possibility to use 150µ alone)
- Contact Brushes
- Free app

FOR WHICH TYPE OF POOLS?

Types of pools	Small to medium public pools (hotels, campsites, apartments) with rigid walls, up to 20m length
Pool shapes	Rectangular, oval, freeshape
All Floors	Flat, gentleslope, composite slope, diamond shape
Pool surfaces	Tiles, liner, polyester hull, reinforced PVC, painted concrete

DESCRIPTION

Cleaning areas	Floor /walls/ waterline
Number / Length of cleaning cycles	Multiple from 0h30 to 6h00 with preset cycles: -Quick: floor only 1h15 -Smart: floor / walls / waterline (calculated time) -Ultra: floor / walls / waterline (2h45)
Timer / Delayed start	7-days timer / Up to 3h delayed start
Power supply	Autonomous, connected to 230V main supply before the transformer
Steering	Pre-programmed
Drive system	Tracks system drive - 2 motors
Transmission	Gear transmission with reinforced components
Pressure sensor	Yes
Brushes	Yes (Contact + ZZ Brushes)
Lift System	Yes
Full filter indicator	Yes
Remote control	Remote control mode (with app)
Water temperature measurement	Yes
Pressure depth sensor	Yes
Safety	Deck system, out of water safety, diagnostic, electronic motor protector
Filtration system / access	Rigid Filter canister with access over the cleaner
Units / pallet	12

TECHNICAL SPECIFICATIONS

Number of motors	3
Control box supply	200-240 VAC ; 50 / 60Hz
Power supply	30 VDC
Operating power	150 W
Cable length / Hose length	25m
Cleaner size (L x W x h)	47 x 51 x 29 cm
Packaging size (L x W x h)	56 x 56 x 46 cm
Cleaner weight	11 kg
Packaging weight	21 kg
Filtering surface and level	1180 cm ³
Filtering capacity	5L
Inlet suction size / /Cleaned width	24,5 cm

OPTIONAL ACCESSORIES (NOT INCLUDED)

Fine filter canister 100µ	Fine filter canister 200µ
R0863600	R0863700

PUBLIC POOL CLEANERS

TRX 7700 iQ - VORTRAX



3 YEAR WARRANTY*



SPECIFICALLY DESIGNED FOR INTENSIVE USE IN PUBLIC POOLS TOUGH, SMART AND ULTRA-EFFICIENT

- + Ultrasonic sensors to detect walls and obstacles
- + SensorNavSystem™: intelligent and personalised cleaning with anti-tangle compass system without the need of swivel
- + New Heavy-duty materials and traction system for intensive use
- + Ultra-powerful & long lasting suction
- + Designed for a professional use in public swimming pools for hotels, campsites and sports centers

REFERENCE PRICE

Standard Model	WR000414
----------------	----------

ACCESSORIES INCLUDED IN THE PACK

- Trolley
- Control box
- Stainless Steel Canister 150µ
- Ultra-Fine Filter canister 60µ
- Contact Brushes
- Free app

FOR WHICH TYPE OF POOLS?

Types of pools	Public pools (hotels, campsites, sports centers) with rigid walls, up to 25m length
Pool shapes	Rectangular, oval, freeshape
All Floors	Flat, gentleslope, composite slope, diamond shape
Pool surfaces	Tiles, liner, polyester hull, reinforced PVC, painted concrete

DESCRIPTION

Cleaning areas	Floor / walls/ waterline
Number / Length of cleaning cycles	Multiple from 0h30 to 6h00 with preset cycles: -Quick: floor only 1h15 -Smart: floor / walls / waterline (calculated time) -Ultra: floor / walls / waterline (2h45)
Timer / Delayed start	7-days timer / Up to 3h delayed start
Power supply	Autonomous, connected to 230V main supply before the transformer
Steering	Pre-programmed
Drive system	Tracks system drive - 2 motors
Transmission	Gear transmission with reinforced components
Pressure sensor	Yes
Brushes	Yes (Contact + ZZ Brushes)
Lift System	Yes
Full filter indicator	Yes
Remote control	Remote control mode (with app)
Ultrasonic sensors	Yes
Water temperature measurement	Yes
Pressure depth sensor	Yes
Safety	Deck system, out of water safety, diagnostic, electronic motor protector
Filtration system / access	Rigid Filter canister with access over the cleaner
Units / pallet	12

TECHNICAL SPECIFICATIONS

Number of motors	3
Control box supply	200-240 VAC ; 50 / 60Hz
Power supply	30 VDC
Operating power	150 W
Cable length / Hose length	30m
Cleaner size (L x W x h)	47 x 51 x 29 cm
Packaging size (L x W x h)	56 x 56 x 46 cm
Cleaner weight	13 kg
Packaging weight	24 kg
Filtering surface and level	1180 cm ³
Filtering capacity	5L
Inlet suction size / Cleaned width	24,5 cm

OPTIONAL ACCESSORIES (NOT INCLUDED)

Fine filter canister 100µ	Fine filter canister 200µ
R0863600	R0863700

PUBLIC POOL CLEANERS

ARCO

ARCO / ARCOMAX



DESIGNED FOR A HEAVY-DUTY AND INTENSIVE USE IN PUBLIC POOLS

- + Infrared sensor to detect walls and obstacles
- + Gyroscope and compass smart navigation system
- + Heavy-duty traction system with tracks for intensive use
- + Ultra-powerful suction
- + Remote control for manual use
- + Designed for a professional use in medium public swimming pools for sports and swimming centers, institutional pools, hotels and campsites



REFERENCE PRICE

Standard Model	WR000396
----------------	----------

ACCESSORIES INCLUDED IN THE PACK

- Trolley
- Remotecontrol
- Capacitative control box
- Dual bag filter
- Free Bluetooth® app

FOR WHICH TYPE OF POOLS?

Types of pools	Medium public pools (sports centers, institutional pools, hotels) with rigid walls, up to 30 m length
Pool shapes	Rectangular, oval, freeshape
All Floors	Flat, gentleslope, composite slope, diamond shape
Pool surfaces	Tiles, liner, polyester hull, reinforced PVC, painted concrete

DESCRIPTION

Cleaning areas	Floor / walls
Number / Length of cleaning cycles	Multiple with preset cycles -Floor Mode: floor -Wall and floor mode: floor walls and waterline/ -Delayed start: the 2 cleaning modes will start with 3 hours delayed
Delayed start	Yes up to 3 hours
Power supply	Autonomous, connected to 230V main supply before the transformer
Steering	Pre-programmed
Drive system	Tracks system drive -2 motors
Transmission	Belt transmission with reinforced components
Infrared sensor	Yes
Brushes	PVA
Full filter indicator	Yes
Remote control	Yes (Bluetooth®)
Filtration system / access	Dual bag filter with access under the cleaner
Units / pallet	9 / pallet

TECHNICAL SPECIFICATIONS

Number of motors	3
Control box supply	110-240 VAC ; 50 / 60 Hz
Power supply	24 VDC
Operating power	150 W
Cable length / Hose length	30 m
Cleaner size (L x W x h)	43 x 43 x 54 cm
Packaging size (L x W x h)	80 x 40 x 60 cm
Cleaner weight	9 kg
Packaging weight	22 kg
Filtering capacity	3,1 kg
Max depth	5 m
Inlet suction size / Cleaned width	40 cm

PUBLIC POOL CLEANERS

ARCOMAX

ARCO / ARCOMAX



DESIGNED FOR A HEAVY-DUTY AND INTENSIVE USE IN MEDIUM AND BIG PUBLIC POOLS

- + Infrared sensor to detect walls and obstacles
- + Gyroscope and compass smart navigation system
- + Heavy-duty traction system with tracks for intensive use
- + Ultra-powerful suction
- + Remote control for manual use
- + Designed for a professional use in medium and big public swimming pools for swimming centers, institutional pools, sports centers and campsites



REFERENCE PRICE

Standard Model	WR0003967
----------------	-----------



ACCESSORIES INCLUDED IN THE PACK

- Trolley
- Remote control
- Capacitive control box
- Dual bag filter
- Free Bluetooth® app

FOR WHICH TYPE OF POOLS?

Types of pools	Medium and big public pools (swim and sports centers, institutional pools) with rigid walls, up to 50 m length
Pool shapes	Rectangular
All Floors	Flat, gentleslope, composite slope, diamond shape
Pool surfaces	Tiles, liner, polyester hull, reinforced PVC, painted concrete

DESCRIPTION	
Cleaning areas	Floor /walls
Number / Length of cleaning cycles	Multiple with preset cycles -Floor Mode: floor -Wall and floor mode: floor walls and waterline/ -Delayed start: the 2 cleaning modes will start with 3 hours delayed
Delayed start	Yes
Power supply	Autonomous, connected to 230V main supply before the transformer
Steering	Pre-programmed
Drive system	Tracks system drive -2 motors
Transmission	Belt transmission with reinforced components
Infrared sensor	Yes
Brushes	PVA
Full filter indicator	Yes
Remote control	Yes (Bluetooth®)
Filtration system / access	Dual bag filter with access under the cleaner
Units / pallet	3 / american pallet

TECHNICAL SPECIFICATIONS	
Number of motors	3
Control box supply	110-240 VAC ; 50 / 60 Hz
Power supply	24 VDC
Operating power	150 W
Cable length / Hose length	40 m
Cleaner size (L x W x h)	80 x 43 x 54 cm
Packaging size (L x W x h)	90 x 51 x 62 cm
Cleaner weight	18 kg
Packaging weight	28 kg
Filtering capacity	5,1 kg
Max depth	5 m
Inlet suction size / Cleaned width	80 m

