

**CATALOGO
SERIE C**

***C SERIES
CATALOGUE***

ea ELECTRO ADDA®
il motore che fa la differenza

MOTORI ASINCRONI TRIFASI

Serie C - Grandezze 63÷500

kW 0,05÷1200

THREE-PHASE ASYNCHRONOUS MOTORS

C Series - Frame sizes 63÷500

kW 0,05÷1200

I dati tecnici, le dimensioni ed ogni altro dato di questo catalogo non sono impegnativi.
ELECTRO ADDA S.p.A. si riserva il diritto di cambiarli in qualsiasi momento e senza preavviso.

Technical data, dimensions, as well as any other data in this catalogue are not binding.
ELECTRO ADDA S.p.A. reserves the right to change them at any time without giving any previous notice.



MOTORI ASINCRONI TRIFASI

Serie C - Grandezze 63÷500

THREE-PHASE ASYNCHRONOUS MOTORS

C Series - Frame sizes 63÷500

Indice

- Validità del catalogo.....	p. 5
- Descrizione generale.....	p. 5
- Ambiente di installazione.....	p. 5
- Norme, Unificazioni.....	p. 6
- Norme UL - CSA - GOST TR CU.....	p. 7
- Dichiarazione di conformità.....	p. 9
- Proprietà riservata.....	p. 10
- Note sulle sigle dei motori.....	p. 10
- Forme costruttive.....	p. 11
- Grado di protezione.....	p. 12
- Particolari costruttivi.....	p. 12
- Targhe.....	p. 13
- Raffreddamento.....	p. 13
- Cuscinetti.....	p. 14
- Posizionamento assiale del rotore.....	p. 14
- Cuscinetti per motori standard.....	p. 15
- Carichi ammessi sui cuscinetti.....	p. 16
- Cuscinetti per carichi radiali elevati.....	p. 21
- Costruzione per carichi radiali elevati.....	p. 22
- Intervalli di lubrificazione.....	p. 24
- Scatola morsetti e morsettieria.....	p. 25
- Scatola morsetti ausiliari.....	p. 28
- Gabbia di rotore.....	p. 29
- Isolamento, avvolgimento.....	p. 29
- Potenze e dati tecnici.....	p. 30
- Tensioni di alimentazione - Collegamenti.....	p. 30
- Oscillazioni di tensione e frequenza.....	p. 31
- Funzionamento multitemperatura e 60 Hz.....	p. 31
- Declassamenti.....	p. 32
- Servizi.....	p. 32
- Sovraccarichi.....	p. 32
- Avviamenti.....	p. 33
- Rumorosità.....	p. 33
- Vibrazioni.....	p. 33
- Protezioni termiche.....	p. 34
- Scaldiglie anticondensa.....	p. 34
- Tappi scarico condensa.....	p. 35
- Viteria inox.....	p. 35
- Verniciatura - Cicli speciali.....	p. 35
- Freni.....	p. 37
- Prove e collaudi.....	p. 37
- Trasduttore di velocità (encoder).....	p. 38
Dati tecnici (alimentazione da rete)	
- Classe di efficienza IE1.....	p. 41
- Classe di efficienza IE2.....	p. 45
- Classe di efficienza IE3.....	p. 48
- Doppia polarità.....	p. 51
- Doppia polarità per ventilatori.....	p. 56
- Alimentazione da inverter.....	p. 60
- Funzionamento a potenza aumentata.....	p. 61
Dati tecnici (alimentazione da inverter)	
- Classe di efficienza IE1.....	p. 62
- Classe di efficienza IE2.....	p. 66
- Classe di efficienza IE3.....	p. 73
- Dimensioni d'ingombro.....	p. 79
- Motori autoventilati (IC 411).....	p. 80
- Motori con ventilazione assistita (IC 416).....	p. 101
- Dimensioni d'ingombro (IC 416).....	p. 102
- Denominazione componenti.....	p. 118

Index

- Validity of the catalogue.....	p. 5
- General description.....	p. 5
- Environment.....	p. 5
- Standards and Standardizations.....	p. 6
- UL - CSA - GOST TR CU Standards.....	p. 7
- Declaration of Conformity.....	p. 9
- Reserved property.....	p. 10
- Note on motors acronyms.....	p. 10
- Mountings and positions.....	p. 11
- Degree of protection.....	p. 12
- Construction details.....	p. 12
- Rating Plates.....	p. 13
- Cooling.....	p. 13
- Bearings.....	p. 14
- Axial rotor positioning.....	p. 14
- Bearings for standard motors.....	p. 15
- Permissible load on the bearings.....	p. 16
- Bearings for high radial loads.....	p. 21
- Construction for high radial loads.....	p. 22
- Lubrication intervals.....	p. 24
- Terminal box and block.....	p. 25
- Auxiliary terminal box.....	p. 28
- Rotor cage.....	p. 29
- Insulation, winding.....	p. 29
- Ratings and technical data.....	p. 30
- Supply voltage - Connections.....	p. 30
- Voltage and frequency variations.....	p. 31
- Operation at different voltages and 60 Hz.....	p. 31
- Deratings.....	p. 32
- Duties.....	p. 32
- Overloads.....	p. 32
- Starting.....	p. 33
- Noise.....	p. 33
- Vibrations.....	p. 33
- Thermal protections.....	p. 34
- Anticondensation heaters.....	p. 34
- Condensation drainage plugs.....	p. 35
- Stainless steel screws and bolts.....	p. 35
- Painting - Special cycles.....	p. 35
- Brakes.....	p. 37
- Tests and controls.....	p. 37
- Speed transducers (encoder).....	p. 38
Technical data (grid supply)	
- IE1 Efficiency class.....	p. 41
- IE2 Efficiency class.....	p. 45
- IE3 Efficiency class.....	p. 48
- Double polarity.....	p. 51
- Double polarity for fans.....	p. 56
- Inverter supply.....	p. 60
- Increased power operating.....	p. 61
Technical data (inverter supply)	
- IE1 Efficiency class.....	p. 62
- IE2 Efficiency class.....	p. 66
- IE3 Efficiency class.....	p. 73
- Overall dimensions.....	p. 79
- Self-ventilated motors (IC 411).....	p. 80
- Motors with assisted ventilation (IC 416).....	p. 101
- Overall dimensions (IC 416).....	p. 102
- Name of Components.....	p. 118



www.imq.it

CERTIFICATO N.
CERTIFICATE N. 9101.ADDA

SI CERTIFICA CHE IL SISTEMA QUALITA' DI
WE HEREBY CERTIFY THAT THE QUALITY SYSTEM OPERATED BY
ELECTRO ADDA SPA COSTRUZIONI ELETTROMECCANICHE

VIA NAZIONALE 8 - 23883 BEVERATE (LC)

UNITA' OPERATIVE
OPERATIVE UNITS

Vedere gli Allegati per le Unità Operative (n° 2 allegati)
View the Annexes for the Operative Units (n° 2 annexes)

E' CONFORME ALLA NORMA
IS IN COMPLIANCE WITH THE STANDARD

ISO 9001:2008

PER LE SEGUENTI ATTIVITA'
FOR THE FOLLOWING ACTIVITIES

Progettazione

CISQ is a member of



www.iqnet-certification.com

IQNet, the association of the world's first class certification bodies, is the largest provider of management System Certification in the world. IQNet is composed of more than 30 bodies and counts over 150 subsidiaries all over the globe.



THE INTERNATIONAL CERTIFICATION NETWORK

CERTIFICATE

IQNet and its partner
CISQ/IMQ-CSQ
hereby certify that the organization

ELECTRO ADDA SPA COSTRUZIONI ELETTROMECCANICHE

VIA NAZIONALE 8 - 23883 BEVERATE (LC)
VIA S. ANNA 640 - 41100 MODENA (MO)

for the following field of activities

*Design, manufacturing and service of LV electric rotary machines for industrial, naval and civil field, in particular: asynchronous three-phases motors with squirrel cage rotor, brake motors with squirrel cage rotor, single-phase motors with squirrel cage rotor, explosion-proof motors with squirrel cage rotor, slip-ring motors, frequency converters, high frequency motors, motors for circular saws, motors for inverter duty.
Sales and service of LV electric rotary machines for industrial, naval and civil field*

Refer to quality manual for details of applications to ISO 9001:2008 requirements

has implemented and maintains a
Quality Management System
which fulfills the requirements of the following standard

ISO 9001:2008

Issued on: 2015 - 09 - 28

Expiry date: 2018 - 09 - 27

Registration Number: IT - 34914

The status of validity of the certificate can be verified at <http://www.cisq.com> or by e-mail to fedcisq@cisq.com



Michael Drechsel

Michael Drechsel
President of IQNET



Ing. Claudio Provetti

Ing. Claudio Provetti
President of CISQ

IQNet Partners*:

AENOR Spain AFNOR Certification France AIB-Vinçotte International Belgium APCER Portugal CCC Cyprus
CISQ Italy CQC China CQM China CQS Czech Republic Cro Cert Croatia DQS Holding GmbH Germany
FCAV Brazil FONDONORMA Venezuela ICONTEC Colombia IMNC Mexico Inspecta Certification Finland INTECO Costa Rica
IRAM Argentina JQA Japan KFQ Korea MIRTEC Greece MSZT Hungary Nemko AS Norway NSAI Ireland PCBC Poland
Quality Austria Austria RR Russia SIGE Mexico SII Israel SIQ Slovenia SIRIM QAS International Malaysia
SQS Switzerland SRAC Romania TEST St Petersburg Russia TSE Turkey YUQS Serbia

anti di BT per il settore industriale,
gabbia, autofrenanti con rotore a
re a gabbia, a rotore avvolto,
e circolari, motori per inverter.
riche rotanti di BT
le
industrial, naval and civil field, in
r, brake motors with squirrel cage
motors with squirrel cage rotor,
rs for circular saws, motors for
industrial, naval and civil field
orma ISO 9001:2008
08 requirements
DEL
STIONE
NSFY THE
ENT SYSTEMS
SCADENZA
EXPIRY
2018-09-27

CISQ è la Federazione Italiana di
Organismi di Certificazione dei
sistemi di gestione aziendale.

CISQ is the Italian Federation
of management system
Certification Bodies.



www.cisq.com

Validità del catalogo

Le informazioni contenute in questo catalogo sono indicative, non impegnano **ELECTRO ADDA** e possono essere modificate da **ELECTRO ADDA** senza alcun preavviso.

Su richiesta in sede di ordine **ELECTRO ADDA** fornirà le informazioni richieste impegnative.

ELECTRO ADDA non è responsabile se i prodotti qui descritti verranno utilizzati al di fuori delle specifiche per le quali sono stati progettati.

Descrizione generale

I motori della serie C presentati in questo catalogo sono conformi alle Norme IEC 60034-30-1 ed al Regolamento Europeo EU MEPS (EU 640/2009) riguardanti l'efficienza energetica dei motori ed appartengono alla classe ad alta efficienza (IE2) e premium (IE3) (entro i limiti prestazionali specificati dalle norme).

Su richiesta, e per applicazioni che non vengano installate in Europa, è possibile fornire tali motori anche per la classe di efficienza standard (IE1). In tal caso, il cliente dovrà fornire una comunicazione scritta che certifichi che l'impianto/la macchina su cui andrà installato il motore IE1 sarà esportata fuori dal territorio della CEE.

I motori della serie C grandezza 63÷500 sono del tipo chiuso, con ventilazione esterna e hanno il rotore a gabbia di scoiattolo.

I motori grandezza 63÷355LT sono caratterizzati dall'aver la carcassa realizzata in lega leggera di alluminio ad alta resistenza (serie CA).

I motori grandezza 355L÷500 sono caratterizzati dall'aver la carcassa realizzata in acciaio (serie CS).

Tutti i motori sono adatti all'alimentazione da inverter.

I motori possono essere personalizzati con un elevato numero di opzioni, varianti costruttive ed accessori, che li rendono idonei a qualsiasi applicazione a velocità variabile, dalle più leggere alle più gravose.

Ambiente di installazione

I motori della serie C descritti nel presente catalogo sono stati progettati e sono costruiti per applicazioni industriali, e quindi sono adatti ad essere installati in normali ambienti industriali.

Normalmente si presume che l'ambiente in cui il motore verrà installato sia:

- secco, ossia con umidità relativa $\leq 75\%$
- libero da agenti chimici, ossia che non siano presenti concentrazioni di gas e/o vapori e/o polveri che possano corrodere chimicamente i materiali di cui sono composti i motori stessi.

Validity of the catalogue

*Information contained in this catalog is indicative and not binding **ELECTRO ADDA** and can be modified by **ELECTRO ADDA** without notice.*

*On request when ordering **ELECTRO ADDA** will provide all requested binding information.*

***ELECTRO ADDA** is not responsible if the products described herein will be used outside of the specifications for which they have been designed.*

General description

C series motors presented in this catalog comply with IEC 60034-30-1 Standards and with the European Rules EU MEPS (EU 640/2009) relating to motors energy efficiency and belong to the high efficiency class (IE2) and premium (IE3) (within the limits specified by the standards).

Upon request, and for applications that are not installed in Europe, it is also possible to supply these motors for the standard class of efficiency (IE1). In this case, the Customer must provide written notice certifying that the plant / machine on which the motor IE1 will be installed will be exported outside the territory of the EEC.

C series motors frame size 63÷500 are totally enclosed, fan cooled, with squirrel cage rotor.

Motors frame size 63÷355LT have a high resistance aluminium light alloy frame (CA series).

Motors frame size 355L÷500 have a welded steel frame (CS series).

All motors are suitable for inverter supply.

Motors can be customized with a large number of options, constructive variants and accessories, which make them suitable for any application at variable speed, from the lightest to the heaviest.

Environment

C series motors described in this catalog are designed and manufactured for industrial applications, and thus are suitable to be installed in normal industrial environments.

Normally it is assumed that the environment in which the motor will be installed is:

- dry, ie with relative humidity $\leq 75\%$
- free from chemicals, namely that there are no concentrations of gases and / or vapors and / or dust that may corrode chemically the materials the motors are made of.

Nel caso di ambienti difficili, il tipo di protezione, di raffreddamento ed i materiali devono essere definiti in sede di offerta.

La temperatura minima di lavoro è di -20°C; in caso di temperature ambiente inferiori, contattare **ELECTRO ADDA**.

I motori della serie C descritti nel presente catalogo NON possono essere installati in ambienti con pericolo di esplosione.

Norme, Unificazioni

I motori serie C sono conformi alle seguenti Norme e Direttive:

CEI	IEC	Titolo	Title
EN 60034-1	60034-1	Caratteristiche nominali e di funzionamento	Rating and performances
EN 60034-2	60034-2	Metodi di determinazione delle perdite e rendimento	Methods for determining losses and efficiency
EN 60034-5	60034-5	Classificazione dei gradi di protezione (codice IP)	Classification of the degrees of protection (IP code)
EN 60034-6	60034-6	Metodi di raffreddamento (codice IC)	Methods of cooling (IC code)
EN 60034-7	60034-7	Tipi di costruzione, forme costruttive e posizione scatola morsetti (codice IM)	Types of construction, mounting arrangements and terminal box position (IM code)
EN 60034-8	60034-8	Marcatura dei terminali e senso di rotazione	Terminal markings and direction of rotation
EN 60034-9	60034-9	Limiti di rumore	Noise limits
60034-11	60034-11	Protezioni termiche a bordo macchina	Built-in thermal protections
EN 60034-12	60034-12	Prestazioni elettriche delle macchine elettriche rotanti all'avviamento	Starting performance of rotating electrical machines
EN 60034-14	60034-14	Vibrazioni meccaniche delle macchine rotanti	Mechanical vibrations of rotating machines
IEC 60034-30 Ed. 1		Classe di efficienza di motori asincroni trifase con rotore a gabbia a singola velocità (codice IE)	Efficiency classes of single-speed, three-phase, cage-induction motors (IE code)
EN 50347	60072-1 60072-2	Dimensioni e potenze delle macchine rotanti	Dimensions and outputs for rotating machines
16-8	1293	Marcatura delle apparecchiature elettriche	Marking of electrical devices
IEC TS 60034-25		Guida per il progetto e le prestazioni di motori ca specificatamente progettati per alimentazione da inverter Specifica tecnica	Guidance for the design and performance of a.c. motors specifically designed for converter supply Technical specification
IEC TS 60034-18-41		Qualificazione e prove di tipo dei sistemi d'isolamento di tipo I utilizzati nelle macchine rotanti alimentate da inverter Specifica tecnica	Qualification and type tests for type I electrical insulation systems used in rotating electrical machines fed from voltage converters Technical specification
UNI ISO 2768/1-2		Tolleranze generali	General tolerances
UNI 321		Estremità d'albero	Shaft end
73/23/EEC		Direttiva bassa tensione	Low voltage directive
89/336/EEC (EMC)		Direttiva compatibilità elettromagnetica	Electromagnetic compatibility directive
2006/42/CE		Direttiva macchine	Machine directive

Le unificazioni UNEL concordano con le norme internazionali IEC, pubblicazione 72, e relativo Emendamento N° 1.

I motori serie C possono essere realizzati anche per applicazioni a bordo di navi; in tal caso sono inoltre conformi alle prescrizioni emesse dagli

In case of harsh environments, type of protection, cooling and materials must be defined when offering.

*Minimum working temperature is -20°C; in case of lower ambient temperatures, please contact **ELECTRO ADDA**.*

C series motors described in this catalog CAN NOT be installed in environments with risk of explosion.

Standards and standardizations

C series motors comply with the following Standards and Directives:

The UNEL standardizations are in accordance with the IEC international standards publication 72 and relative Amendment No. 1.

C series motors can also be manufactured for applications on shipboard; in this case they are also in compliance with the prescriptions issued by

enti di classificazione:
Registro Italiano Navale
Lloyds Register of Shipping
Bureau Veritas
American Bureau of Shipping
Det Norske Veritas
ecc...

Norme UL - CSA - GOST TR CU

I motori del presente catalogo possono essere forniti a richiesta secondo i requisiti delle Norme UL 1004-1 Rotating Electric Machines - General Requirements, First Edition, e delle Norme CSA C22.2 No. 100-04, Motors and Generators, Sixth Edition (Certificato di Conformità No. 20101119-E340019 emesso da Underwriters Laboratories).

A richiesta, possono anche essere forniti con certificato GOST TR CU (certificato 1323158), in conformità alle seguenti Regole Tecniche dell'Unione Doganale fra Russia, Bielorussia e Kazakistan:

- TP TC 004/2001 Low Voltage
- TP TC 020/2011 EMC

(Dichiarazione di Conformità TR CU numero TC RU D-IT.AP16.V.04674 (marchio EAC)).

Questa Dichiarazione di Conformità si applica in Russia, Bielorussia e Kazakistan.

the following Classification Bodies:

Registro Italiano Navale
Lloyds Register of Shipping
Bureau Veritas
American Bureau of Shipping
Det Norske Veritas
etc...

UL - CSA - GOST TR CU Standards

Motors in this catalog can be supplied, on request, to meet the requirements of UL Standards 1004-1 Rotating Electric Machines - General Requirements, First Edition, and CSA Standards C22.2 No. 100-04, Motors and Generators, Sixth Edition (Certificate of Conformity No. 20,101,119 -E340019 issued by Underwriters Laboratories).

On request, they can also be supplied with GOST TR CU Certification (Nr.1323158), in conformity with the following Custom Union Technical Regulation among Russia, Bielorussia and Kazakhstan:

- TP TC 004/2011 Low Voltage
- TP TC 020/2011 EMC

(Declaration of Conformity TR CU number TC RU D-IT.AP16.V.04674 (EAC mark)).

This Declaration of Conformity is applicable in Russia, Bielorussia and Kazakhstan.



Tutti i motori serie C sono progettati, realizzati, assemblati e collaudati presso lo stabilimento ELECTRO ADDA di BEVERATE di BRIVIO - Lecco - ITALY.

All C series motors are designed, manufactured, assembled and tested at ELECTRO ADDA works in BEVERATE di BRIVIO - Lecco - ITALY.

Certificate of Compliance

Certificate Number 151205 - E247839
 Report Reference E247839, November 23rd, 2005
 Issue Date 2005 December 15

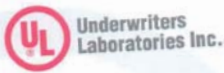

Issued to: **Electro Adda S.p.A.**
 Via Nazionale 8
 I-23883 Brivio (LC) Italy

This is to certify that representative samples of

MOTORS

Motor constructions for three phase squirrel cage induction motors, Regular Double Pole Motor series RM 100/1, 4, 6, 8, 10, 12, 15, 18, 22, 25, 28, 32, 35, 38, 40, 45, 50, 55, 60, 63, 70, 75, 80, 90, 100, 112, 125, 140, 160, 180, 200, 225, 250, 280, 315, 355 (D.M., L, S, T) 05, 03, 01, 03-05, 03-01, 04, V1, V6, V3 and Regular Single Pole Motor series RM 100/1, 4, 6, 8, 10, 12, 15, 18, 22, 25, 28, 32, 35, 38, 40, 45, 50, 55, 60, 63, 70, 75, 80, 90, 100, 112, 125, 140, 160, 180, 200, 225, 250, 280 (D.M., L, S, T) 05, 03, 01, 03-05, 03-01, 04, V1, V6, V3.

Have been investigated by Underwriters Laboratories Inc. in accordance with the Standard(s) indicated on this Certificate.

Standard(s) for Safety: **UL 1004 - Electric Motors
 CSA C22.2 No. 100-95 - Motors and Generators**

Additional Information: See Addendum for Electrical Rating

Only those products bearing the UL Recognized Component Mark for the U.S. may be considered as being covered by UL's Recognition and Follow-Up Service—appropriate U.S. and Canadian requirements. The UL Recognized Component Mark for the U.S. generally consists of the manufacturer's identification number, model number or other product designation as specified under "Marking" for the particular product. As a supplementary means of identifying products that are recognized under UL's Component Recognition Program, UL's Recognized Component Mark may be used under UL's Component Recognition Program. The Recognized Component Mark is required when specifying with the required Recognition Mark for the individual requirements. The UL Directory providing the recognition or under "Marking" for the individual requirements. The UL Directory providing the recognition or under "Marking" for the individual requirements. The UL Directory providing the recognition or under "Marking" for the individual requirements. The UL Directory providing the recognition or under "Marking" for the individual requirements.

Look for the UL Recognized Component Mark on the

Issued by: *Biagio Di Sanzo*
 Biagio Di Sanzo, Engineering Associate
 UL International Italia Srl
 Any information and documentation provided by you involving UL Mark services are provided on behalf of Underwriters Laboratories Inc.
 For specifications see: <http://www.ul.com> or call 1-888-458-6200.

СИСТЕМА СЕРТИФИКАЦИИ ГОСТ Р ФЕДЕРАЛЬНОЕ АГЕНТСТВО ПО ТЕХНИЧЕСКОМУ РЕГУЛИРОВАНИЮ И МЕТРОЛОГИИ



СЕРТИФИКАТ СООТВЕТСТВИЯ

№ РОСС ПА.АГ98.Н06410
 Срок действия с 13.05.2013 по 12.05.2016

ОРГАН ПО СЕРТИФИКАЦИИ рег. № РОСС RU.0001.11АГ98. Орган по сертификации продукции ООО "ЮгРесурс". 117342, г. Москва, ул. Введенского, д. 23А, стр. 3, тел. 8 985 766 92 24, E-mail info@ug-resurs.ru. № 1323158

ПРОДУКЦИЯ Двигатели и генераторы асинхронные мощностью свыше 100 кВт, т.м. "Electro Adda", серий: С, FC, FCP, FW, W, MR, FMR, C+FECCL, FC+FECCL, FCP+FECCL, MR+FECCL, FMR+FECCL, G. Серийный выпуск.

КОД ОК 005 (ОКП):
33 3000

СООТВЕТСТВУЕТ ТРЕБОВАНИЯМ НОРМАТИВНЫХ ДОКУМЕНТОВ
 ГОСТ Р 51689-2000 (п.п. 4.7-4.9, 5.4, 5.6)

КОД ТН ВЭД России:
8501 53 810 0

ИЗГОТОВИТЕЛЬ "Electro Adda S.P.A."
 Адрес: Via Nazionale, 8, 23883, Beverate di Brivio, LC, Италия.
 Телефон +39 039 5320621.

СЕРТИФИКАТ ВЛААН "Electro Adda S.P.A."
 Адрес: Via Nazionale, 8, 23883, Beverate di Brivio, LC, Италия.
 Телефон +39 039 5320621.

НА ОСНОВАНИИ протокола № ТС4/1-м/0021 от 08.05.2013 г., испытательная лаборатория ООО "Слектр", аттестат рег. № РОСС RU.0001.21АВ92 от 21.10.2011 г., адрес: 121351, г. Москва, ул. Ивана Франко, д.18, корп.1

Схема сертификации: 3.

[Signature]
 Н.В. Линева
 Б.С. Мигачев
 при обязательной сертификации

Certificate of Compliance



Certificate: 1045308
 Project: 1848621
 Issued to: **Electro Adda S.p.A.**
 Via Nazionale, 8
 Beverate - Brivio, Como 23883
 ITALY

Master Contract: 201661
 Date Issued: October 31, 2006

The products listed below are eligible to bear the CSA Mark shown with adjacent indicators 'C' and 'US'



Issued by: G. Foulem
[Signature]
 Authorized by: M.H.J. Hoendervangers
[Signature]

PRODUCTS

- 4211-01 - MOTORS AND GENERATORS
- 4211-81 - MOTORS AND GENERATORS - Certified for US Standard

Three phase squirrel cage induction motor, permanently connected, component type, class F, 40°C ambient, TEFC, Frame IEC 56-400, max 600Vac, rated out Power 0.09 to 500 kW, 60Hz, 2 to 8 poles, continuous duty. Series RM (regular motors).

Three phase squirrel cage induction motor, permanently connected, component type, class F, 40°C ambient, TEFC, Frame IEC 80-315, max 600Vac, rated out Power 0.75 to 160 kW, 60Hz, 4 poles, continuous duty. Series HEM (High efficiency motors)

Certified as a component motor for use in other equipment where suitability of the combination is to determined by CSA International.

APPLICABLE REQUIREMENTS

- CSA Standard C22.2 No. 0-M91 - General Requirements – Canadian Electrical Code, Part II
- CSA Standard C22.2 No. 100-04 - Motors and generators
- UL standard 1004 - Electric Motors

The 'C' and 'US' indicators adjacent to the CSA Mark signify that the product has been evaluated to the applicable CSA and ANSI/UL Standards, for use in Canada and the U.S., respectively. This 'US' indicator includes products eligible to bear the 'NRTL' indicator. NRTL, i.e. National Recognized Testing Laboratory, is a designation granted by the U.S. Occupational Safety and Health Administration (OSHA) to laboratories which have been recognized to perform certification to U.S. Standards.



EAC ТАМОЖЕННЫЙ СОЮЗ
ДЕКЛАРАЦИЯ О СООТВЕТСТВИИ

Заявитель, ООО «ВИК-Индустри»
600016, г. Владимир, ул. Б. Нижегородская, д. 77, Россия, тел. +74922370339, ОГРН 1073340004858

в лице Генерального директора Байкина Александра Александровича
заявляет, что Двигатели асинхронные, т.м. "Electro Adda", серий: C, FC, FCP, FW, W, FMR, C+FECCCL, FC+FECCCL, FCP+FECCCL, MR+FECCCL, FMR+FECCCL, G.
изготовитель: "Electro Adda S.P.A.", Via Nazionale, 8, 23883, Beverate di Brivio, LC, Италия
Код ТН ВЭД ТС: 8501 53810
Серийный выпуск, Договор № 130829 от 06.09.2012 г.

соответствует требованиям
ТР ТС 004/2011 "О безопасности низковольтного оборудования"; ТР ТС 020/2011 "Электромагнитная совместимость технических средств"

Декларация о соответствии принята на основании
протоколов №№ TC2/3-ма/0178, TC2/3-ма/0179 от 08.05.2013 г. Испытательная лаборатория ООО "Спектр", аттестат рег. № РОСС RU.0001.21AB92 от 21.10.2011 г., адрес: 121351 г. Москва, ул. Ивана Франко, д.18, корп.1

Дополнительная информация
Декларация о соответствии действительна с даты регистрации по включительн.но. Байкин Александр Александрович (инициалы и фамилия руководителя организации заявителя или физического лица, зарегистрированного в качестве индивидуального предпринимателя)

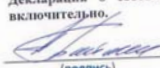
(подпись)

М.П.

Сведения о регистрации декларации о соответствии:
Регистрационный номер декларации о соответствии: TC RU Д-ИТ.АЛ16.В.04670
Дата регистрации декларации о соответствии: 13.05.2013

EAC ТАМОЖЕННЫЙ СОЮЗ
ДЕКЛАРАЦИЯ О СООТВЕТСТВИИ

Заявитель, ООО «ВИК-Индустри»
600016, г. Владимир, ул. Б. Нижегородская, д. 77, Россия, тел. +74922370339, ОГРН 1073340004858

в лице Генерального директора Байкина Александра Александровича
заявляет, что Электрогенераторы асинхронные, т.м. "Electro Adda", серий: C, FC, FCP, FW, W, MR, FMR, C+FECCCL, FC+FECCCL, FCP+FECCCL, MR+FECCCL, FMR+FECCCL, G.
изготовитель: "Electro Adda S.P.A.", Via Nazionale, 8, 23883, Beverate di Brivio, LC, Италия
Код ТН ВЭД ТС: 8501 53810
Серийный выпуск, Договор № 130829 от 06.09.2012 г.

соответствует требованиям
ТР ТС 004/2011 "О безопасности низковольтного оборудования"; ТР ТС 020/2011 "Электромагнитная совместимость технических средств"

Декларация о соответствии принята на основании
протоколов №№ TC2/3-ма/0176, TC2/3-ма/0177 от 08.05.2013 г. Испытательная лаборатория ООО "Спектр", аттестат рег. № РОСС RU.0001.21AB92 от 21.10.2011 г., адрес: 121351 г. Москва, ул. Ивана Франко, д.18, корп.1

Дополнительная информация
Декларация о соответствии действительна с даты регистрации по 12.05.2018 включительно. Байкин Александр Александрович (инициалы и фамилия руководителя организации заявителя или физического лица, зарегистрированного в качестве индивидуального предпринимателя)

(подпись)

М.П.

Сведения о регистрации декларации о соответствии:
Регистрационный номер декларации о соответствии: TC RU Д-ИТ.АЛ16.В.04670
Дата регистрации декларации о соответствии: 13.05.2013

Dichiarazione di conformità

ELECTRO ADDA dichiara che i motori asincroni trifase della serie C sono realizzati in conformità alle seguenti normative internazionali:

- IEC34 (CEI EN 60034)
- ed alle seguenti Direttive Europee:
 - Direttiva Bassa Tensione (LVD) 2006/95/CE
 - Direttiva Compatibilità Elettromagnetica (EMC) 2004/108/CE
 - Direttiva sulla limitazione dell'impiego di alcune sostanze pericolose nelle apparecchiature elettriche ed elettroniche (RoHS) 2002/95/CE
 - Direttiva Progettazione Eco-compatibile (Eco-Design) 2009/125/CE

I motori di questo catalogo sono inoltre conformi alla Direttiva Macchine 2006/42/CE, assumendo per questa che il componente motore non può essere messo in servizio prima che la macchina, in cui sarà incorporato, sia stata dichiarata conforme alle disposizioni della Direttiva. Nell'impiego del motore è necessario garantire il rispetto della norma EN 60204-1 e delle istruzioni di sicurezza e di installazione riportate nel manuale d'uso del produttore.

Declaration of Conformity

ELECTRO ADDA declares that the C series three-phase asynchronous motors are manufactured in accordance with the following international standards:

- IEC34 (IEC EN 60034)
- and the following European Directives:
 - Low Voltage Directive (LVD) 2006/95/EC
 - Electromagnetic Compatibility Directive (EMC) 2004/108/EC
 - Directive on the Restriction of certain Hazardous Substances in electrical apparatus and electronic equipment (RoHS) 2002/95/EC
 - Directive Eco-friendly Designing (Eco-Design) 2009/125/EC

Motors in this catalog are also in conformity with Machine Directive 2006/42/EC, assuming that the component motor can not be put into service until the machinery into which it is incorporated has been declared in conformity with the provisions of the Directive. When using the motor it is necessary to ensure compliance with the EN 60204-1 and safety instructions and installation instructions in the manufacturer's user manual.

Proprietà riservata

Questo catalogo ed il suo contenuto sono di esclusiva proprietà di **ELECTRO ADDA S.p.A.**

È vietata la riproduzione anche parziale dello stesso e/o del suo contenuto, senza l'esplicito consenso scritto di **ELECTRO ADDA S.p.A.**

Nota sulle sigle dei motori

I motori descritti nel presente catalogo vengono individuati secondo le seguenti sigle:

Reserved property

This catalog and its contents are the sole property of **ELECTRO ADDA S.p.A.**

It is forbidden even partial reproduction of the same and/or its content without the express written consent of **ELECTRO ADDA S.p.A.**

Note on motors acronyms

Motors described in this catalogue have the following acronyms:

Forma costruttiva Mounting arrangement	P < 0,75kW P > 375kW		IE1		IE2		IE3	
	CA: carcassa in alluminio - CS: carcassa in acciaio CA: aluminium frame - CS: welded steel frame							
B3	CA	CS	C1A	C1S	C2A	C2S	C3A	C3S
B5 - V1 e derivate/and derivated	FCA	FCS	FC1A	FC1S	FC2A	FC2S	FC3A	FC3S
B3/B5 e derivate/and derivated	FCAP	FCSP	FC1AP	FC1SP	FC2AP	FC2SP	FC3AP	FC3SP
B3/B14 e derivate/and derivated	FCAP	FCSP	FC1AP	FC1SP	FC2AP	FC2SP	FC3AP	FC3SP

Nota 1 - la lettera "F" prima della sigla indica un motore con sola flangia (senza piedi).

Nota 2 - la lettera "F" prima della sigla e la lettera "P" dopo la sigla indicano un motore con flangia e con piedi.

La sigla completa del motore è poi integrata dall'altezza d'asse, la lunghezza della carcassa ed il numero di poli.

Esempi:

C2A132S-4, motore serie CA, IE2, con piedi, grandezza 132, lunghezza S, 4 poli

FC2A132S-4, motore serie CA, IE2, con flangia, grandezza 132, lunghezza S, 4 poli

FC2AP132S-4 motore serie CA, IE2, con piedi e flangia, grandezza 132, lunghezza S, 4 poli

Note 1: letter "F" means a motor with flange (no feet).

Note 2: letter "F" and letter "P" mean a motor with flange and feet.

Complete acronym is then completed by shaft height, frame length and pole number.

Examples:

C2A132S-4, CA series motor, IE2, with feet, frame 132, length S, 4 pole

FC2A132S-4, CA series motor, IE2, with flange, frame 132, length S, 4 pole







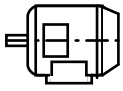
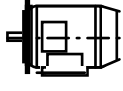
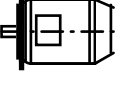
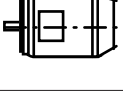

FC2AP132S-4, CA series motor, IE2, with feet and flange, frame 132, length S, 4 pole

Forme costruttive

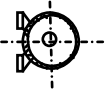
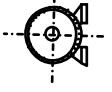
Mountings and positions

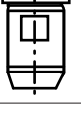
Le forme costruttive secondo IEC 60034-7 relative ai motori standard sono indicate con i codici elencati nella seguente tabella.

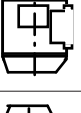
Mountings and positions for standard motors, according to IEC 60034-7, are defined by the codes mentioned in the following table.

Figura Drawing	Norme di riferimento - Reference standards			Altezze d'asse - Frame sizes			
	CEI 2-14	IEC 60034-7		63÷160	180÷250	280÷355LT	355L÷500
		Code I	Code II				
	B3	IM B3	IM 1001	Di serie Standard			
	B3/B5	IM B35	IM 2001	Di serie Standard			
	B5	IM B5	IM 3001	Di serie Standard	Di serie Standard	A richiesta Upon request	A richiesta Upon request
	B14	IM B14	IM 3601	Di serie Standard	-	-	-
	B8	IM B8	IM 1071	Di serie Standard	A richiesta Upon request	A richiesta Upon request	-
	B 6	IM B6	IM 1051	Di serie Standard	A richiesta Upon request	A richiesta Upon request	-
	B7	IM B7	IM 1061	Di serie Standard	A richiesta Upon request	A richiesta Upon request	-
	V1	IM V1	IM 3011	Di serie Standard			
	V3	IM V3	IM 3031	Di serie Standard	Di serie Standard	A richiesta Upon request	-
	V5	IM V5	IM 1011	Di serie Standard	A richiesta Upon request	A richiesta Upon request	-
	V6	IM V6	IM 1031	Di serie Standard	A richiesta Upon request	A richiesta Upon request	-
	V1/V5	IM V15	IIM 2011	Di serie Standard	A richiesta Upon request	A richiesta Upon request	-

Grado di protezione

I motori serie C, in accordo con le Norme IEC 60034-5, hanno i seguenti gradi di protezione:

IP 55 (di serie). Motori chiusi con ventilazione esterna protetti alla penetrazione di polvere e getti d'acqua provenienti da ogni direzione.

IP 56 (a richiesta). Motori stagni protetti alla penetrazione della polvere e contro le ondate.

La ventola esterna è coperta da una calotta avente grado di protezione IP 20 (cioè è protetta contro l'accesso involontario delle dita).

A richiesta, i motori previsti per l'installazione con asse verticale con albero verso il basso, vengono forniti con il tettuccio di protezione.

La scatola morsettiera ha il grado di protezione IP 55 o IP 56.

Particolari costruttivi

I motori serie C sono stati progettati e vengono realizzati in modo da assicurare la massima affidabilità e sicurezza d'esercizio.

I motori serie C grandezza 63÷355LT hanno la carcassa realizzata in alluminio (sigla CA).

I motori grandezza 63÷200T hanno gli scudi e le flange realizzate in alluminio, mentre i motori 200÷355LT hanno gli scudi e le flange realizzati in ghisa.

I motori grandezza 355L÷500 hanno la carcassa realizzata in acciaio (sigla CS).

I motori grandezza 355L÷400 hanno gli scudi realizzati in ghisa, mentre i motori grandezza 450÷500 hanno gli scudi realizzati in acciaio.

La scatola copri morsettiera, realizzata in alluminio, è posta sopra al motore ed è ruotabile di 90° in 90°.

A richiesta la scatola morsetti può essere posta lateralmente al motore.

La calotta copriventola è metallica in lamiera o in alluminio.

Le ventole sono realizzate in materiale plastico, in alluminio o in acciaio.

Degree of protection

C series motors, according to IEC 60034-5 Standards, have the following protection degrees:

IP 55 (standard). *Totally enclosed motors, fan cooled, protected against penetration of dust and water splashes coming from any direction.*

IP 56 (upon request). *Totally enclosed motors, protected against dust penetration and against sea waves.*

The external fan is covered by a fan cover with IP 20 protection degree (accidental contact of fingers is avoided).

Upon request, motors for vertical mounting, can be supplied with rain cowl.

The terminal box has IP 55 or IP 56 protection degree.

Construction details

C series motors have been designed and manufactured to guarantee maximum operating reliability and safety.

C series motors frame size 63÷355LT are provided with aluminium frame (CA denomination).

Motors frame size 63÷200T are provided with aluminium shields and flanges while motors frame size 200÷355LT have cast iron shields and flanges.

Motor frame size 355L÷500 are provided with welded steel frame (CS denomination).

Motors frame size 355L÷400 are provided with cast iron shields, while motors frame size 450÷500 are provided with welded steel shields.

Terminal box, made in aluminium, is positioned on top of the motor and it can be rotated in step of 90°.

Upon request the terminal box can be positioned on the side of the motor.

Fan cover is in metal, in steel sheet or aluminium.

Fans are made in plastic, aluminium or steel.

	Grandezza - Frame size				
	Serie CA - CA Series			Serie CS - CS Series	
	63÷132	160÷200T	200÷355LT	355÷400	450÷500
Carcassa - Frame	Alluminio - Aluminium			Acciaio - Steel	
Scudo LA Front (DE) shield	Alluminio - Aluminium		Ghisa - Cast iron	Ghisa - Cast iron	Acciaio - Steel
Scudo LOA Rear (NDE) shield	Alluminio - Aluminium		Ghisa - Cast iron	Ghisa - Cast iron	Acciaio - Steel
Flangia - Flange	Alluminio - Aluminium	Ghisa - Cast iron		Ghisa - Cast iron	Acciaio - Steel
Albero - Shaft	Acciaio C43 - Steel C43				
Scatola morsetti Terminal box	Alluminio - Aluminium			Acciaio - Steel	
Ventola - Fan	Alluminio - Aluminium			Acciaio - Steel	

Targhe

Tutti i motori in esecuzione standard sono forniti con targa in alluminio o a richiesta in acciaio inossidabile.

Tutte le targhe, realizzate mediante incisione laser, riportano i dati caratteristici della macchina elettrica in accordo con le norme di riferimento.

A richiesta del cliente possono essere aggiunte targhe speciali riportanti caratteristiche particolari. Per esempio: Item di impianto, ecc...

Raffreddamento

La definizione del metodo di raffreddamento è data dal codice IC (International Cooling), in accordo alla IEC 60034-6.

I motori in esecuzione standard sono caratterizzati dal metodo di raffreddamento IC 411, con ventola radiale bidirezionale.

Tutti i motori possono essere forniti con sistema di raffreddamento IC 416 su richiesta (vedere pag. 101).

In tal caso viene installato un opportuno ventilatore nel coprimentello adeguatamente rinforzato, in modo da rendere la ventilazione indipendente dalla velocità di rotazione.

A richiesta possono essere forniti motori con sistema di raffreddamento IC 418; in tal caso il motore viene fornito senza ventola ed il raffreddamento è garantito da un flusso d'aria che lambisce il motore stesso. Qualora il flusso d'aria sia sufficientemente elevato è possibile aumentare la potenza erogata dal motore.

Per gli aumenti di potenza consentiti in questa configurazione è necessario interpellare **ELECTRO ADDA S.p.A.**

Rating Plates

All motors in standard execution are supplied with aluminium rating plate or, upon request, with stainless steel rating plate.

All rating plates, made by laser engraving, contain the distinctive data of the electric machine according to the reference standards.

Upon customer's request, special rating plates mentioning particular features can be added. For example: system item, etc...

Cooling

The designation of cooling method is given by the IC (International Cooling) code, according to IEC60034-6

Motors in standard execution are supplied with IC 411 cooling systems, incorporating a bi-directional fan.

All frame sizes can be supplied with cooling system IC 416, on request (see page 101).

In this case a proper fan is fitted inside the fan cover, suitably reinforced, in order to make the ventilation independent of the rotation speed.

On request motors with IC 418 cooling systems can be supplied; in such case the motor is supplied without fan and the cooling is ensured by a flow of air that flows around the motor itself. If the airflow is high enough it is possible to increase the power delivered by the motor.

*For power increases allowed in this configuration, please ask **ELECTRO ADDA S.p.A.***

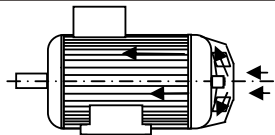
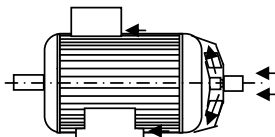
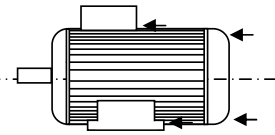
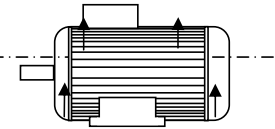
Codice IC IC code	Figura - Drawing	Descrizione	Description
IC 411 Std		Motore autoventilato. Macchina chiusa, alettata esternamente. Ventola esterna montata sull'albero del motore.	Self ventilating motor. Enclosed machine. Externally finned. External shaft-mounted fan.
IC 416 Su richiesta Upon request		Motore con ventilazione assistita. Macchina chiusa, alettata esternamente. Ventilatore indipendente montato sotto coprimentello.	Motor with assisted ventilation. Enclosed machine. Externally finned. Independent external fan mounted inside the fan cover.
IC 418 Su richiesta Upon request		Motore con ventilazione esterna. Macchina chiusa, alettata esternamente. Raffreddamento assicurato da un dispositivo non montato sul motore.	Motor with external ventilation. Enclosed machine. Externally finned. Ventilation provided by air flowing from the driven system.
IC 410 Su richiesta Upon request		Motore senza ventilazione. Macchina chiusa, alettata esternamente. Ventilazione naturale	Motor without ventilation. Enclosed machine. Externally finned. Natural ventilation.

A richiesta i motori possono essere forniti anche senza ventilazione (IC 410). In quest'ultimo caso le caratteristiche, le potenze e i dati tecnici, saranno forniti a richiesta.

Upon request they can be supplied without fan. (IC 410). In this case the features, outputs and technical data will be supplied upon request.

Cuscinetti

Tutti i motori serie C hanno i cuscinetti a sfere (radiali od obliqui) od a rulli, lubrificati a grasso.

I motori serie CA grandezze 63÷250 hanno i cuscinetti a sfere stagni pre-lubrificati. Il grasso contenuto all'interno è sufficiente per tutta la vita del cuscinetto, pertanto non necessitano di rilubrificazione.

I motori serie CA grandezze 280÷355LT e serie CS grandezze 355L÷500 hanno i cuscinetti a sfere (radiali od obliqui) o a rulli, lubrificati a grasso con ingrassatori su ambo i lati. Per questi cuscinetti è necessario provvedere ad una periodica rilubrificazione secondo i dati indicati nella tabella di pagina 22 e sulla targa del motore, e secondo le modalità indicate nel manuale di uso e manutenzione.

I coperchietti esterni sono di forma e dimensioni tali da consentire un elevato accumulo di grasso esausto (10-12 lubrificazioni) e sono dotati di tappo di scarico.

A richiesta i motori, a partire dalla grandezza 160, possono essere forniti con cuscinetto a rulli lato accoppiamento.

Sui motori verticali viene installato superiormente un apposito cuscinetto reggispinta in grado di reggere il peso del motore e di un eventuale giunto di accoppiamento.

A richiesta le macchine possono essere predisposte per il sistema di monitoraggio SPM (Shock Pulse Method) su entrambi i cuscinetti.

A richiesta possono essere installati su entrambi i cuscinetti sensori di temperatura Pt-100 per controllare la loro corretta temperatura.

Tutti i cuscinetti sono previsti per una durata di funzionamento (in base ai dati dei fabbricanti) di almeno 40.000 ore, con accoppiamento diretto.

Posizionamento assiale del rotore

Il rotore può scorrere assialmente a seconda del tipo di cuscinetto installato e dal posizionamento delle molle di precarico. Nella tabella è indicato quale cuscinetto è bloccato e la posizione delle molle di precarico.

Bearings

All C series motors have ball bearings (radial or oblique) or roller bearings, grease lubricated.

CA series motors frame size 63 ÷250 have sealed prelubricated bearings. The grease contained inside is sufficient for the whole bearing life, therefore they do not need to be relubricated.

CA series motors frame size 280÷355LT and CS series motors frame size 355L÷500 have ball bearings (radial or oblique) or roller bearings, grease lubricated, with lubricators on both sides. These bearings need to be periodically relubricated according to the data given in the table on page 22 and on the motor name plate, and according to the directions given in the operating and maintenance manual.

The shape and dimensions of the bearing outer covers allow a high exhausted grease accumulation (10-12 lubrications) and are provided with drain plug.

Upon request, starting from size 160, motors can be supplied with roller bearing on the drive end.

On vertical motors a proper thrust bearing is fitted on top, able to hold the weight of the motor and of a coupling, if available.

Upon request, machines can be prepared for fitting the SPM monitoring system (Shock Pulse Method) on both bearings.

Upon request, Pt-100 thermal detector can be fitted on both bearings, in order to check the correct bearing temperature.

The lifetime of bearings (in accordance with supplier data) is at least 40.000 hours, for motors with direct coupling.

Axial rotor positioning

The rotor can slide axially depending on the bearing type installed and the position of the preloading springs. The table shows what bearing is secured and the position of the preloading springs.

Grandezza Frame size	Disposizione orizzontale - Horizontal arrangement			Disposizione verticale - Vertical arrangement	
	Cuscinetto bloccato Secured bearing		Posizionamento molle di precarico Preloading springs position	Cuscinetto bloccato Secured bearing	Posizionamento molle di precarico Preloading springs position
	Standard	Carichi radiali elevati High radial loads			
63÷132	-	-	LOA - NDE	-	LOA - NDE
160÷200	-	LOA - NDE	LOA - NDE	-	LOA - NDE
225÷280	LA - DE	LOA - NDE	-	LA - DE	-
315S	LA - DE	LOA - NDE	-	LA - DE	-
315M (2 poli-poles)	LA - DE	-	-	LOA - NDE	-
315M (4, 6, 8 poli-poles)	-	LOA - NDE	-	LOA - NDE	-
355L	LA - DE	LOA - NDE	-	LOA - NDE	-
355Lx÷500	LA - DE	LOA - NDE	-	LOA - NDE	-

Cuscinetti per motori standard

Bearings for standard motors

Serie CA - Carcassa in alluminio

CA Series - Aluminium Frame

Motore tipo - <i>Motor Type</i>	Poli - <i>Poles</i>	Forma costruttiva B3 - <i>Mounting B3</i>	
		Cuscinetto LA - <i>DE bearing</i>	Cuscinetto LOA - <i>NDE bearing</i>
63	2÷8	6202-2Z	6202-2Z
71	2÷8	6203-2Z	6203-2Z
80	2÷8	6204-2Z	6204-2Z
90S-L	2÷8	6205-2Z	6205-2Z
100L	2÷8	6206-2Z	6206-2Z
112MT-M	2÷8	6206-2Z	6206-2Z
132S-M	2÷8	6208-2Z	6208-2Z
160MT	2÷8	6309-2Z	6308-2Z
160M-L	2÷8	6309-2Z	6309-2Z
180MT-LT	2÷8	6310-2Z	6309-2Z
180L	2÷8	6311-2Z	6311-2Z
200LT	2÷8	6312-2Z	6311-2Z
200L	2÷8	6312-2Z	6312-2Z
225MT	2	6313-2Z	6313-2Z
225ST-MT-M	4÷8	6313-2Z	6313-2Z
250MT-M	2÷8	6314-2Z	6314-2Z
280ST-MT	2	6316-C3	6314-C3
280ST-MT	4÷8	6316-C3	6314-C3
315ST	2	6314-C3	6314-C3
315ST	4÷8	6317-C3	6314-C3
315M	2	6314-C3	6314-C3
315M*	4÷8	NU317	6317-C3
355LT	2	6317-C3	6317-C3
355LT*	4÷8	NU322	6320-C3

*Le grandezze 315M e 355LT vengono fornite di serie in costruzione carichi radiali elevati

*Sizes 315M and 355LT are supplied as a standard in high radial loads construction

Serie CS - Carcassa in acciaio

CS Series - Steel Frame

Motore tipo <i>Motor type</i>	Poli <i>Poles</i>	Forma costruttiva B3 - <i>Mounting B3</i>		Forma costruttiva V1 - <i>Mounting V1</i>		
		Cuscinetto LA <i>DE bearing</i>	Cuscinetto LOA <i>NDE bearing</i>	Cuscinetto LA <i>DE bearing</i>	Cuscinetto LOA - <i>NDE bearing</i>	
					Standard	A richiesta - <i>Upon request</i>
355L	2	6317-C3	6317-C3	6317-C3	7317	
355L	4÷8	6322-C3	6320-C3	6322-C3	6322-C3	7320
355Lx	4÷8	6324-C3	6322-C3	6324-C3	7320	
400Lx	4÷8	6324-C3	6322-C3	6324-C3	7322	
450Lx	4÷8	6324-C3	6324-C3	6324-C3	7324	
500Lx	4÷8	6328-C3	6324-C3	6328-C3	7324	

Carichi ammessi sui cuscinetti

La durata di base teorica a fatica dei cuscinetti è calcolata in accordo con quanto previsto dalla norma ISO R 281-1.

La durata è calcolata nell'ipotesi che i motori siano funzionanti in condizioni ambientali normali, senza vibrazioni anomale, senza carichi assiali o radiali oltre quelli indicati nelle tabelle successive e con temperature di funzionamento dei cuscinetti comprese tra -30°C e $+85^{\circ}\text{C}$.

La durata così calcolata viene definita durata di base (L10h) espressa in ore di funzionamento.

Il 50% dei cuscinetti raggiunge una durata pari a cinque volte la durata di base risultante dal calcolo.

Nelle tabelle seguenti sono indicati i massimi carichi assiali e radiali ammessi per una durata di base (L10h), calcolata con secondo quanto previsto dalle Norme ISO, pari a 20.000 e 40.000 ore di funzionamento.

Si ricorda che le durate dei cuscinetti sono calcolati su coefficienti di carico dinamico forniti dai costruttori dei cuscinetti.

Tali carichi sono basati sulla durata che si prevede che possa venir raggiunta o superata dal 90% dei cuscinetti di una campionatura sufficientemente grande, costituita da unità apparentemente tutte uguali.

Il 50% dei cuscinetti può raggiungere una durata cinque volte superiore a quella indicata dal calcolo.

Il 10% dei cuscinetti, tuttavia, può non raggiungere la durata di vita calcolata.

Permissible load on the bearings

The theoretical basic fatigue life for bearings is calculated according to the provisions of the ISO R 281-1 Standard.

Life is calculated assuming that motors are running under normal ambient conditions, without abnormal vibrations, without axial or radial loads beyond the ones mentioned in the following tables and with operating temperatures of the bearings ranging between -30°C and $+85^{\circ}\text{C}$.

Life calculated this way is called basic life (L10h) expressed in hours of operation.

50% of bearings reaches a life equal to five times the basic life resulting from the calculation.

Next tables show the maximum permitted axial and radial loads for a basic life (L10h), calculated according to the provisions of the ISO Standards, equal to 20.000 and 40.000 hours of operation.

It should be noted that the bearing life is calculated on dynamic load coefficients supplied by bearings manufacturers.

These loads are based on the life that is expected to be reached or exceeded by 90% of bearings of a sufficiently large sampling, consisting of units apparently all the same.

50% of bearings can reach a life five times longer than the one indicated by the calculation.

10% of bearings, however, cannot reach the calculated life.

Carichi assiali ammessi
Forma IM-B3 IM-B35 (alimentazione 50 Hz)

Permissible axial loads
Mounting IM-B3 IM-B35 (50 Hz)

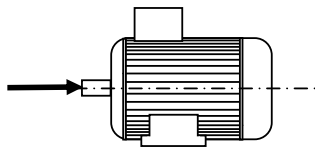
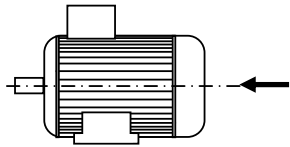
Grandezza Frame size																
	Forza assiale (N) - Axial force (N)								Forza assiale (N) - Axial force (N)							
	2 Poli - Poles		4 Poli - Poles		6 Poli - Poles		8 Poli - Poles		2 Poli - Poles		4 Poli - Poles		6 Poli - Poles		8 Poli - Poles	
	20.000 ore hours	40.000 ore hours	20.000 ore hours	40.000 ore hours	20.000 ore hours	40.000 ore hours	20.000 ore hours	40.000 ore hours	20.000 ore hours	40.000 ore hours	20.000 ore hours	40.000 ore hours	20.000 ore hours	40.000 ore hours	20.000 ore hours	40.000 ore hours
63	380	290	510	385	600	440	700	530	235	133	380	250	460	322	560	400
71	460	340	620	470	720	530	840	630	310	190	390	225	500	310	610	430
80	620	470	850	635	1030	760	1200	900	480	320	680	460	880	620	1070	760
90	660	490	890	658.6	1040	769.6	1220	910	530	360	720	480	900	640	1100	780
100	930	690	1200	880	1430	1050	1950	1460	690	450	880	570	1200	820	1470	1020
112	900	670	1170	850	1400	1020	1920	1440	680	430	830	510	1150	780	1400	970
132	1450	1080	1850	1340	2150	1570	2540	1870	1080	690	1260	750	1760	1170	2180	1500
160	2430	1800	3150	2331	3700	2730	4400	3300	2200	1580	2600	1750	3500	2500	4200	3100
180MT	2800	2070	3700	2700	-	-	-	-	2600	1870	2900	1950	-	-	-	-
180L	-	-	3700	2600	3400	2470	4000	2930	-	-	3700	2600	3200	2250	3800	2700
200LT	3700	2700	4100	2850	5700	4200	5200	3850	3700	2700	4100	2850	5700	4200	5200	3850
225MT	4100	3000	4500	3050	6300	4600	7200	5200	4100	3000	4500	3050	6300	4600	7200	5200
250MT	4700	3500	5000	3400	7200	5300	8200	6050	4700	3500	5000	3400	7200	5300	8200	6050
280ST	4600	3400	5500	3550	6800	5000	7600	5550	4600	3400	5500	3550	6800	5000	7600	5550
280MT	4500	3300	5000	3050	6600	4850	7400	5350	4500	3300	5000	3050	6600	4850	7400	5350
315ST	4400	3200	5000	2950	6200	4500	7000	5060	4400	3200	5000	2950	6200	4500	7000	5060
315Ma	4300	3150	4100	2000	6100	3650	10000	7250	4300	3150	4100	2000	6100	3650	10000	7250
315Mb	4200	3050	3200	NP	6200	3800	9700	7050	4200	3050	3200	NP	6200	3800	9700	7050
315Mc	4100	2900	1900	NP	5100	2800	9400	6800	4100	2900	1900	NP	5100	2800	9400	6800
315Md	-	-	-	-	4300	2000	9200	6500	-	-	-	-	4300	2000	9200	6500
355LT	-	-	-	-	4300	2000	9200	6500	-	-	-	-	4300	2000	9200	6500
355L	5100	3600	-	-	-	-	-	-	5100	3600	-	-	-	-	-	-
355L-a	5000	3500	5100	2000	6500	-	12800	9200	5000	3500	5100	3600	6500	3000	12800	9200
355L-b	4800	3300	4800	1500	4800	-	12300	8700	4800	3300	5000	3500	4800	NP	12300	8700
355L-c	4500	3050	3800	-	3600	-	11700	8200	4500	3050	4800	3300	3600	NP	11700	8200
355Lx-a	4600	3100	3500	-	2000	-	11000	7400	4600	3100	4500	3050	1700	NP	11000	7400
355Lx-b	4300	2850	-	-	1000	-	10300	6800	4300	2850	4600	3100	-	-	10300	6800
355Lx-c	4050	2650	-	-	-	-	-	-	4050	2650	4300	2850	-	-	-	-
400Lx-b	-	-	-	-	-	-	10300	6900	-	-	-	2650	-	-	-	6900
400Lx-c	-	-	-	-	-	-	9500	6000	-	-	-	-	-	-	-	6000
450Lx-a	-	-	-	-	-	-	9300	5900	-	-	-	-	-	-	-	5900
450Lx-b	-	-	-	-	-	-	8600	5300	-	-	-	-	-	-	-	5300
500Lx-a	-	-	-	-	-	-	8400	5000	-	-	-	-	-	-	-	5000
500Lx-b	-	-	-	-	-	-	7600	4400	-	-	-	-	-	-	-	4400
500Lx-c	-	-	-	-	-	-	6700	3500	-	-	-	-	-	-	-	3500

Per forme costruttive diverse o per carichi combinati (assiali e radiali) consultare **ELECTRO ADDA**.

• Please ask **ELECTRO ADDA** for other mounting arrangements or simultaneous radial and axial forces.

Carichi assiali ammessi
Forma IM-V1 (alimentazione 50 Hz)

Permissible axial loads
Mounting IM-V1 (50 Hz)

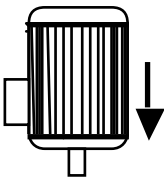
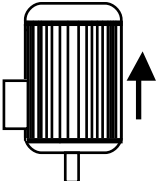
Grandezza Frame size					Forza assiale (N) verso il basso Axial force (N) in downwards direction								Forza assiale (in N) verso l'alto Axial force (N) in upwards direction			
	2 Poli - Poles		4 Poli - Poles		6 Poli - Poles		8 Poli - Poles		2 Poli - Poles		4 Poli - Poles		6 Poli - Poles		8 Poli - Poles	
	20.000 ore hours	40.000 ore hours	20.000 ore hours	40.000 ore hours	20.000 ore hours	40.000 ore hours	20.000 ore hours	40.000 ore hours	20.000 ore hours	40.000 ore hours	20.000 ore hours	40.000 ore hours	20.000 ore hours	40.000 ore hours	20.000 ore hours	40.000 ore hours
63	225	125	390	250	460	300	550	370	400	300	540	405	610	460	610	460
71	300	180	400	230	470	290	560	360	480	360	650	490	750	570	750	570
80	450	290	690	460	860	590	1050	740	670	510	900	680	1060	810	1060	810
90	500	320	730	490	870	590	1060	740	720	550	970	730	1150	863	1150	850
100	650	380	900	590	1100	740	1400	900	1000	760	1300	1000	1550	1200	1600	1200
112	620	380	860	540	1050	700	1500	1100	1000	770	1300	1000	1550	1200	1600	1200
132	980	600	1320	800	1700	1000	2000	1350	1600	1250	2100	1600	2500	1900	2600	1780
160	2000	1400	2650	1840	3200	2200	4000	2900	2750	2100	3600	2800	4300	3300	4400	3400
180MT	2300	1600	2300	2050	-	-	-	-	2700	2100	3700	2750	-	-	-	-
180L	-	-	3800	2700	3600	2500	4400	3100	-	-	4800	3700	4250	3150	4600	3500
200	3200	2250	4300	3000	5100	3450	5800	4650	3850	2900	-	-	6700	5200	6300	5000
225	3600	2500	4700	3250	5500	3800	6400	4400	5000	3850	6500	5000	7700	6000	8300	6650
250	4100	2850	5100	3500	6200	4100	7200	5050	5600	4300	7400	5700	8800	6800	9800	7600
280ST	3700	2200	5800	3950	7200	5000	8000	5600	5900	4700	9200	7300	10800	8500	9800	9100
280MT	3400	2150	5400	3500	6700	4400	7700	5100	6100	4900	9400	7400	11200	8900	10000	9400
315ST	3000	1800	-	-	6500	4300	7900	5200	6300	5100	-	-	12200	9800	10000	10100
315Ma	2800	1550	5400	3550	6600	4350	8000	5400	6600	5300	10300	8300	12000	9500	12700	10000
315Mb	2400	1200	4900	2850	6200	3800	7600	5000	6800	5600	10800	8700	12000	9800	13000	10200
315Mc	2000	800	4300	2300	5000	2800	6800	4200	7000	5800	11300	9300	12800	10400	13500	10800
315Md	-	-	3300	1350	4200	1900	6200	3500	-	-	11800	9700	13500	11000	13600	11000
355LT	-	-	3300	1350	4200	1900	6200	3500	-	-	11800	9700	13500	11000	13600	11000
355L	12200	8800	-	-	7800	4600	-	-	-	-	-	-	17600	14300	-	-
355L-a	11800	8300	6200	3500	6500	3300	9000	5300	-	-	15000	12000	18500	15000	18700	15100
355L-b	11000	7500	6100	3300	5800	2600	7500	4000	-	-	14900	12300	19000	15600	19400	15800
355L-c	10000	6500	5300	2600	5000	1600	6000	2500	-	-	15500	12600	19800	16300	20300	16500
355Lx-a	10000	6700	21500	16000	22000	15000	22000	14400	-	-	-	-	-	-	-	-
355Lx-b	9000	5600	20500	14500	20500	13800	19500	12000	-	-	-	-	-	-	-	-
355Lx-c	8000	4700	19000	13300	-	-	-	-	-	-	-	-	-	-	-	-
355Lx-d	-	-	17500	11400	-	-	-	-	-	-	-	-	-	-	-	-
400Lx-a	-	-	18500	11800	23000	15300	23500	15500	-	-	-	-	-	-	-	-
400Lx-b	-	-	15800	9000	21000	13800	20500	12200	-	-	-	-	-	-	-	-
400Lx-c	-	-	-	-	19000	11300	-	-	-	-	-	-	-	-	-	-
450Lx-a	-	-	18000	11000	21000	12300	18500	10000	-	-	-	-	-	-	-	-
450Lx-b	-	-	16200	8500	17500	9000	19500	10300	-	-	-	-	-	-	-	-
500Lx-a	-	-	14500	7000	19500	11000	19500	10000	-	-	-	-	-	-	-	-
500Lx-b	-	-	-	-	16000	7500	16000	7000	-	-	-	-	-	-	-	-
500Lx-c	-	-	12800	5300	-	-	12500	3000	-	-	-	-	-	-	-	-

Per forme costruttive diverse o per carichi combinati (assiali e radiali) : Please ask **ELECTRO ADDA** for other mounting arrangements or simultaneous radial and axial forces.
consultare **ELECTRO ADDA**.

Carichi radiali ammessi Forma IM-B3 IM-B35 (alimentazione 50 Hz)

I valori dei carichi radiali sono dati sia per carichi applicati all'estremità dell'albero (X_{max}) che in corrispondenza della battuta sul mozzo dell'albero (X_0).

I carichi radiali applicabili variano linearmente con il variare del punto di applicazione, pertanto per carichi posti ad una distanza X dalla battuta dell'albero (X_0), il carico massimo applicabile è dato dalla seguente espressione:

$$Fra_x = \frac{C_{x0} - C_{xmax}}{X_{max}} \times X + C_{xmax}$$

Dove:

- Fra** = carico radiale ammesso nel punto X
- C_{x0}** = carico radiale ammesso nel punto X_0
- C_{xmax}** = carico radiale ammesso nel punto X_{max}
- X_{max}** = sporgenza d'albero
- X** = distanza dal punto di applicazione del carico radiale alla battuta dell'albero

Per verificare che il tiro di cinghia non superi i valori massimi ammessi, si può utilizzare la seguente formula:

$$F = \frac{19100 \times P \times K}{n \times D}$$

Dove:

- F** = Forza radiale in N
- P** = Potenza trasmessa in kW
- n** = Velocità in giri/min
- D** = Diametro della puleggia in metri
- K = 2** per pulegge con tenditore
- K = 2.25** per pulegge con profilo a "V"
- K = 2.5÷3** per cinghie piane senza tenditore, o per servizi pesanti con tutti i tipi di puleggia

Permissible radial loads Mounting IM-B3 IM-B35 (50 Hz)

Values of the radial loads are given both for loads applied to the shaft extension (X_{max}) and in correspondence of the face on the shaft hub (X_0).

Radial loads that can be applied linearly, change with the change of the application point, therefore for loads placed at a distance X from the shaft face (X_0), the maximum load that can be applied is given by the following expression:

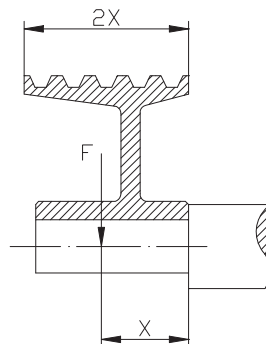

Where:

- Fra** = permitted radial load at point X
- C_{x0}** = permitted radial load at point X_0
- C_{xmax}** = permitted radial load at point X_{max}
- X_{max}** = shaft extension
- X** = distance from the application point of the radial load to the shaft face

To verify that the belt pull does not exceed the maximum value allowed the following formula can be used:

Where:

- F** = Newton radial force
- P** = Power transmitted in kW
- n** = Number of revs. per minute
- D** = Pulley diameter in metres
- K = 2** for flat pulley with tension roller
- K = 2.25** for sheaves with "V" belt
- K = 2.5÷3** for flat belts without tension roller, or for heavy duty with any type of pulley

Carichi radiali ammessi
Forma IM-B3 (50 Hz)

Permissible radial loads
Mounting IM-B3 (50 Hz)

Grandezza Frame size	2 Poli - Poles		4 Poli - Poles		6 Poli - Poles		8 Poli - Poles		2 Poli - Poles		4 Poli - Poles		6 Poli - Poles		8 Poli - Poles	
	20.000 ore hours	40.000 ore hours	20.000 ore hours	40.000 ore hours	20.000 ore hours	40.000 ore hours	20.000 ore hours	40.000 ore hours	20.000 ore hours	40.000 ore hours	20.000 ore hours	40.000 ore hours	20.000 ore hours	40.000 ore hours	20.000 ore hours	40.000 ore hours
	X_0	X_{max}	X_0	X_{max}	X_0	X_{max}	X_0	X_{max}	X_0	X_{max}	X_0	X_{max}	X_0	X_{max}	X_0	X_{max}
63	450	390	350	300	570	490	450	390	630	540	500	430	770	660	600	520
71	530	450	420	350	690	580	540	460	750	630	590	490	900	770	720	610
80	720	590	560	460	920	750	720	580	1080	880	840	690	1300	1040	1000	820
90	800	640	610	500	1000	810	770	630	1130	920	870	700	1300	1050	1020	830
100	1100	900	870	700	1350	1080	1050	830	1570	1260	1220	1000	1900	1550	1500	1200
112	1100	870	840	680	1300	1050	1000	800	1500	1200	1150	930	1900	1550	1500	1200
132	1800	1400	1400	1100	2100	1690	1600	1300	2300	1900	1800	1430	2800	2250	2150	1700
160	3000	2350	2300	1800	3700	2800	2850	2200	4200	3300	3200	2500	4800	3700	3700	2900
180MT-LT	3500	2800	2700	2220	4300	3400	3350	2700	4800	3800	3600	2900	5500	4400	4300	3400
180L-LT	4000	3400	3100	2700	5000	4000	3900	3200	5600	4200	4200	3200	6000	4500	4700	3500
200	4600	3840	3600	2900	6400	5100	4400	3600	6600	5500	5100	4200	7300	6000	5600	4600
225	5200	4300	4000	3400	6400	5100	5000	4000	7400	6000	5600	4500	8200	6600	6300	5000
250	5900	4851	4600	3700	7100	5800	5400	4400	8200	6700	6300	5100	9200	7600	7100	5800
280	5800	4874	4400	3700	8300	7000	6300	5300	9900	8400	7600	6400	10700	9000	8100	6800
315ST	5400	4573	4100	3400	8000	6700	6100	5000	9400	8000	7100	6000	10000	8400	7500	6300
	5300	4600	3900	3300	Vedere costruzione per carichi radiali elevati - See construction for high radial loads											
355L	6400	5700	4600	4100	13000	11000	9900	8300	15200	13000	11200	9500	14000	12000	10000	8500
355Lx					12500	10500	9000	7700	14900	12800	11000	9500	15500	13300	11300	9700
400	-	-	-	-	11200	10000	7800	6900	13500	12000	9700	8500	14800	13000	10500	9300
450	-	-	-	-	14300	12600	10200	9100	15900	14000	11200	10000	17800	15500	13000	11500
500	-	-	-	-	14000	12300	10000	8900	15700	13800	11100	9700	16100	14000	11000	9650

Per forme costruttive diverse o per carichi combinati (assiali e radiali) : Please ask **ELECTRO ADDA** for other mounting arrangements or simultaneous radial and axial forces.
consultare **ELECTRO ADDA**.

Cuscinetti per carichi radiali elevati (a richiesta) *Bearings for high radial loads (upon request)*

Serie CA - Carcassa in alluminio

CA Series - Aluminium Frame

Motore tipo Motor Type	Poli Poles	Forma costruttiva B3 - Mounting B3	
		Cuscinetto LA - DE bearing	Cuscinetto LOA - NDE bearing
160M-L	4÷8	NU309	6309-2Z
180MT-LT	4÷8	NU310	6309-2Z
180L	4÷8	NU311	6311-2Z
200LT	4÷8	NU312	6311-2Z
200L	4÷8	NU312	6312-2Z
225ST-MT-M	4÷8	NU313	6313-2Z
250MT-M	4÷8	NU314	6314-2Z
280ST-MT	4÷8	NU316	6314-C3
315ST	4÷8	NU317	6314-C3
315M*	4÷8	NU317	6317-C3
355LT*	4÷8	NU322	6320-C3

*Le grandezze 315M e 355LT vengono fornite di serie in costruzione carichi radiali elevati

*Sizes 315M and 355LT are supplied as a standard in high radial loads construction

Serie CS - Carcassa in acciaio

CS Series - Steel Frame

Motore tipo Motor Type	Poli Poles	Forma costruttiva B3 - Mounting B3	
		Cuscinetto LA - DE bearing	Cuscinetto LOA - NDE bearing
355L	2	NU317	6317-C3
355L	4÷8	NU322	6320-C3
355Lx	4÷8	NU324	6322-C3
400Lx	4÷8	NU324	6322-C3
450Lx	4÷8	NU328	6324-C3
500Lx	4÷8	NU328	6324-C3

Nei diagrammi delle pagine seguenti sono indicati i massimi carichi radiali ammessi per una durata di base (L10h), calcolata con secondo quanto previsto dalle Norme ISO, pari a 20.000 ore.

Qualora fossero richiesti carichi o durate calcolate superiori a quelli indicati nei diagrammi si prega di interpellare **ELECTRO ADDA**.

The next tables show the maximum permitted axial and radial loads for a basic life (L10h), calculated according to the provisions of the ISO Standards, equal to 20.000 hours.

Please ask **ELECTRO ADDA** in case calculated loads or life higher than the ones mentioned in the tables are required.

Costruzione per carichi radiali elevati

Construction for high radial loads

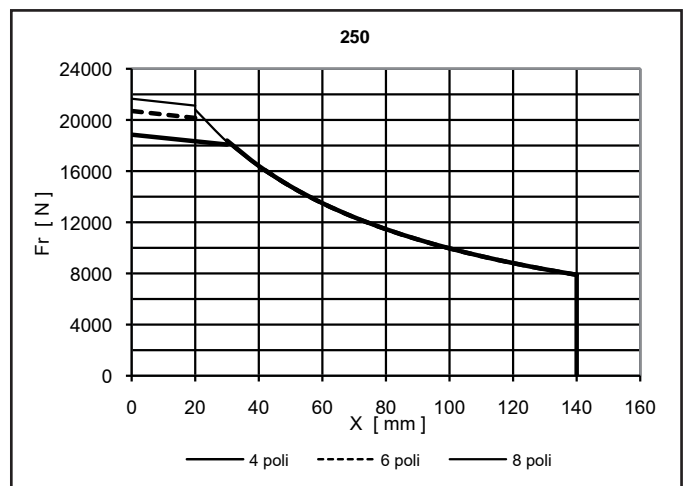
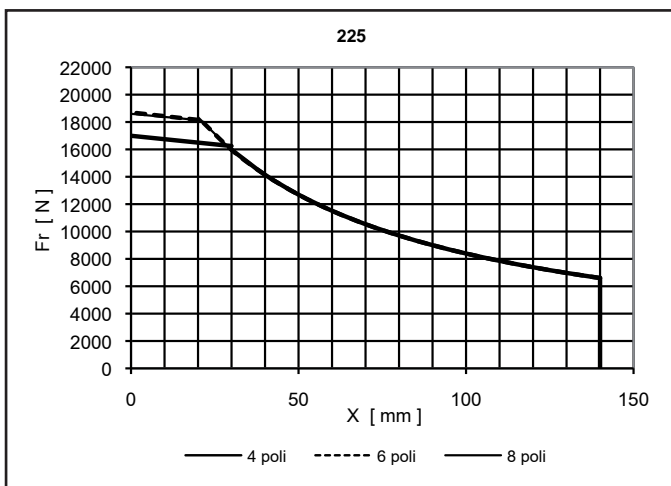
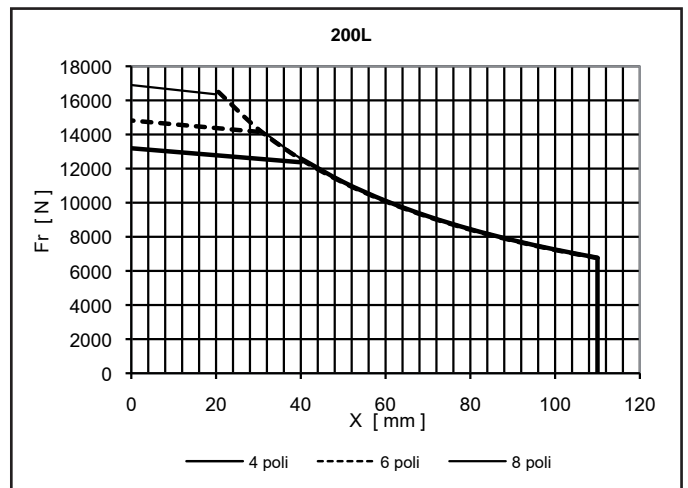
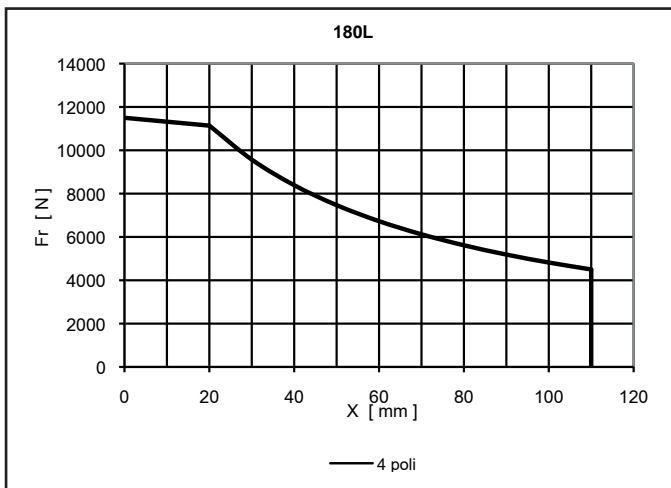
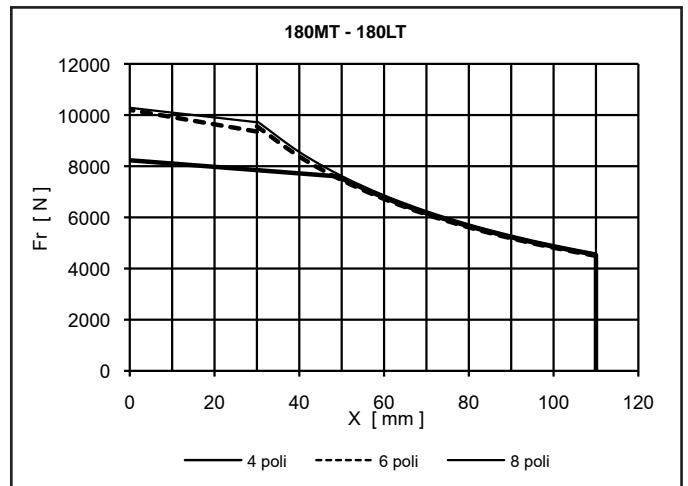
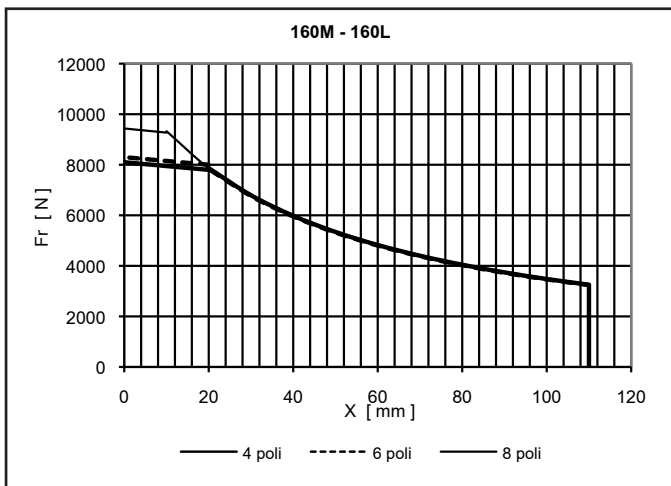

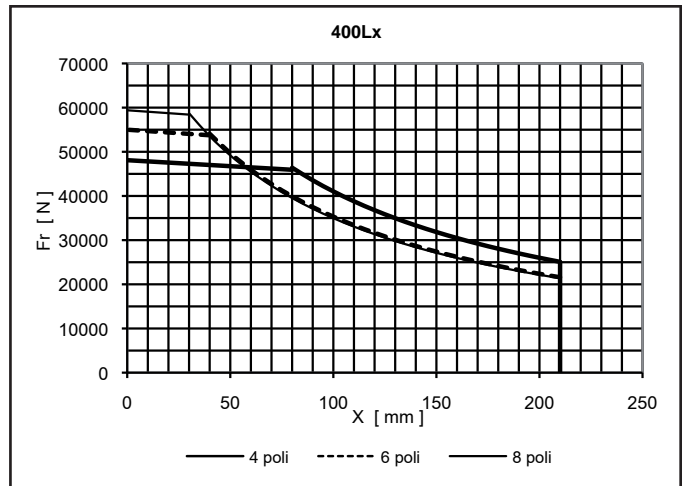
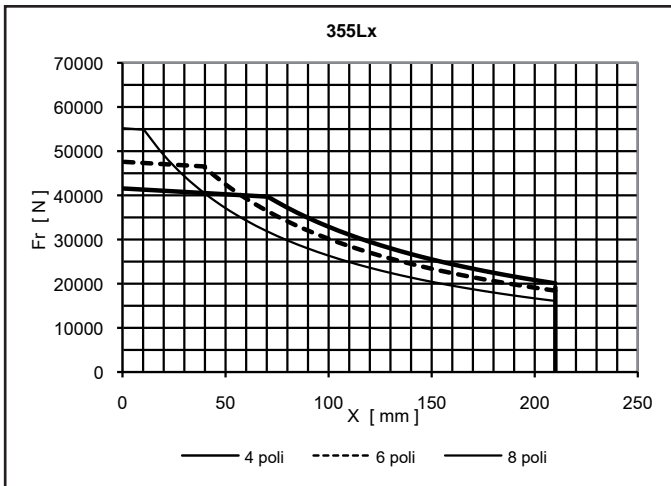
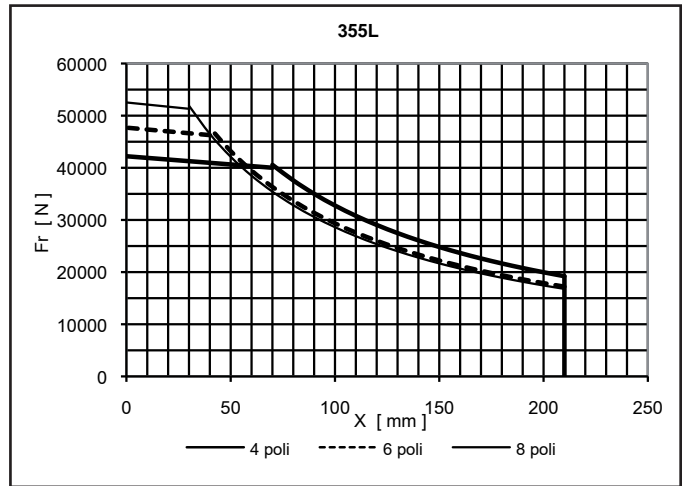
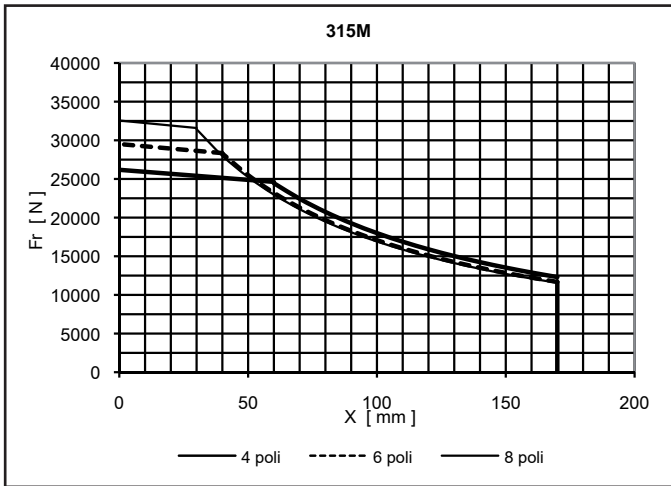
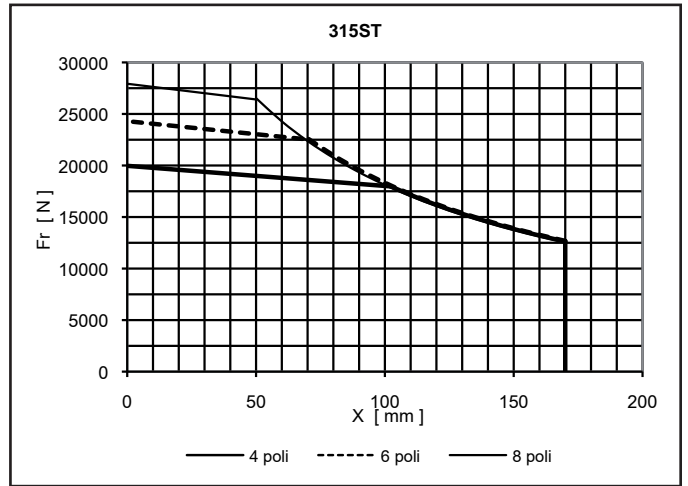
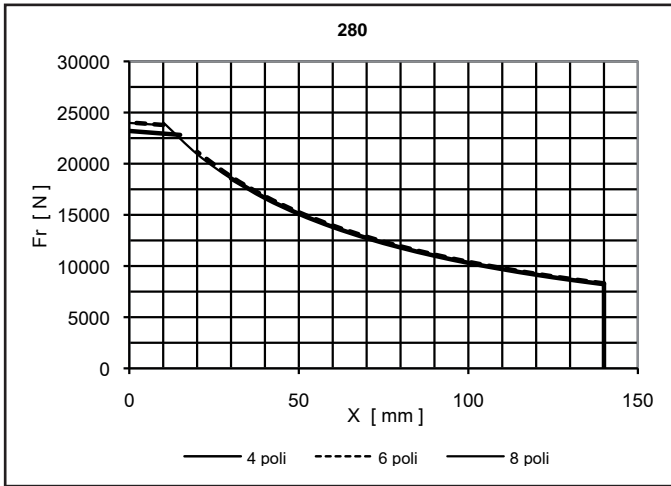

Intervalli di lubrificazione

Lubrication intervals

Nella tabella sono riportati gli intervalli di lubrificazione (espressi in ore) e le quantità di grasso per la lubrificazione dei cuscinetti.

Si consiglia di utilizzare il grasso SKF LGHP2 o corrispondenti.

Il grasso di lubrificazione, normalmente utilizzato per la lubrificazione dei cuscinetti è idoneo per il funzionamento a temperature comprese tra -40°C e +150°C.

In the following table the lubrication intervals (expressed in hours) and the grease quantity to lubricate bearings are showed.

Recommended grease types are SKF LGHP2 or corresponding types.

Lubrication grease normally used to lubricate bearings, is suitable for operating temperatures between -40°C and +150°C.

Grandezza Frame size	Dimensioni Dimension	50 Hz				60 Hz				Quantità di grasso Grease quantity
		2 Poli - Poles	4 Poli - Poles	6 Poli - Poles	8 Poli - Poles	2 Poli - Poles	4 Poli - Poles	6 Poli - Poles	8 Poli - Poles	
		d x D x B	h	h	h	h	h	h	h	
6309-C3	45-100-25	3500	6400	8100	9300	2800	5600	7300	8500	13
6310-C3	50-110-27	3300	6200	7900	9100	2600	5500	7200	8400	13
6311-C3	55-120-29	3000	6000	7700	8900	2200	5200	6900	8100	17
6312-C3	60-130-31	2600	5600	7300	8600	1800	4800	6500	7800	20
6313-C3	65-140-33	2400	5400	7200	8500	1600	4600	6400	7700	23
6314-C3	70-150-35	2200	5300	7100	8300	1400	4500	6300	7500	26
6316-C3	80-170-39	2000	5100	6900	8200	1200	4300	6100	7400	33
6317-C3	85-180-41	1900	5000	6800	8100	1000	4200	6000	7300	37
6320-C3	100-215-47	-	4800	6700	8000	-	4000	5900	7200	51
6322-C3	110-240-50	-	4800	6700	8000	-	4000	5800	7200	60
6324-C3	120-260-55	-	3900	5800	7200	-	3000	5000	6300	72
6328-C3	140-300-62	-	3900	5800	7200	-	3000	5000	6300	93
NU309	45-100-25	1600	3000	4000	4500	1200	2700	3600	4500	13
NU310	50-110-27	1500	2900	3800	4400	1100	2500	3400	4000	13
NU311	55-120-29	1400	2900	3700	4400	1000	2500	3400	4000	17
NU312	60-130-31	1300	2800	3600	4300	900	2400	3200	3900	20
NU313	65-140-33	1200	2700	3600	4200	800	2300	3200	3800	23
NU314	70-150-35	1100	2600	3500	4100	700	2200	3100	3700	26
NU316	80-170-39	1000	2500	3400	4100	600	2100	3000	3700	33
NU317	85-180-41	900	2500	3400	4000	500	2100	3000	3600	37
NU320	100-215-47	-	2400	3300	4000	-	2000	2900	3600	51
NU322	110-240-50	-	2300	3200	3900	-	1900	2800	3500	60
NU324	120-260-55	-	2200	3100	3800	-	1800	2700	3400	72
NU328	140-300-62	-	2000	3000	3600	-	1600	2500	3200	93
7317	85-180-41	-	4800	6700	8000	-	4000	5900	7200	37
7320	100-215-47	-	3900	5800	7200	-	3000	5000	6300	51
7322	110-240-50	-	3900	5800	7200	-	3000	5000	6300	60
7324	120-260-55	-	3900	5800	7200	-	3000	4900	6300	72

Gli intervalli di lubrificazione sono riferiti ad una temperatura del cuscinetto di circa 80°C, nel caso di funzionamento a temperature inferiori tali intervalli possono essere aumentati. Per i motori coin asse verticale, gli intervalli di lubrificazione devono essere dimezzati

Lubrication intervals are referred to a bearing temperature of approx. 80°C, in case of operation at lower temperatures, these intervals can be increased. For motors with vertical axis, lubrication intervals must be halved.

Scatola morsetti e morsettiera

La morsettiera dei motori grandezza 63÷355 è normalmente a sei morsetti.

Nel caso di motori con collegamento a triangolo è pertanto possibile realizzare (se consentito dalle caratteristiche della macchina comandata) l'avviamento stella-triangolo.

Nella morsettiera dei motori grandezza 400÷500 sono normalmente previsti 3 soli morsetti (uno per ogni fase) ai quali vengono collegati i cavi di alimentazione.

In tal caso il collegamento degli avvolgimenti è realizzato all'interno della macchina stessa e non è accessibile.

A richiesta, anche i motori grandezza 400÷500 possono essere realizzati con 6 morsetti in modo da avere tutti i terminali degli avvolgimenti accessibili.

La basetta portamorsetti è di materiale antimuffa non igroscopico.

La scatola morsettiera ha il grado di protezione IP 55 o IP 56, purché il collegamento dei cavi di alimentazione sia realizzato in modo adeguato.

La scatola morsettiera è posta sulla parte superiore del motore e l'uscita cavi può essere realizzata su ogni lato della scatola (da precisare in sede d'ordine).

A richiesta, se è prevista l'uscita dei cavi verso il basso, è possibile fornire un opportuno condotto sagomato per facilitare l'ingresso dei cavi.

A richiesta, è anche possibile posizionare la scatola morsetti a destra o a sinistra del motore guardando dal lato albero.

Terminal box and block

The terminal block for motors frame size 63÷355 is normally provided with six terminals.

Therefore, in case of motors with delta connection, it is possible to perform the start-delta starting (if this is allowed by the features of the driven machine).

The terminal block for motors frame size 400÷500 is normally provided with 3 terminals only (one each phase), to which the supply cables are connected.

In this case the winding connection is made inside the machine and it is not accessible.

Upon request, motors frame size 400÷500 can be equipped with 6 terminals in order to have all winding terminals accessible.

The terminal block is made with non-hygroscopic and anti-mold material.

Terminal box has IP 55 or IP 56 protection degree, provided that the supply cable connections are properly made.

Terminal box is positioned on the top of the motors and cable exit can be made in each side of the box (to be specified when placing the order).

Upon request, if the cable exit is provided downwards, it is possible to supply a proper shaped conduit to make the cable entry easy.

Upon request the terminal box can also be positioned on the right or on the left of the motor seen from the shaft.

Dimensioni scatola in alluminio e morsettiera

Sizes of aluminium terminal box and block

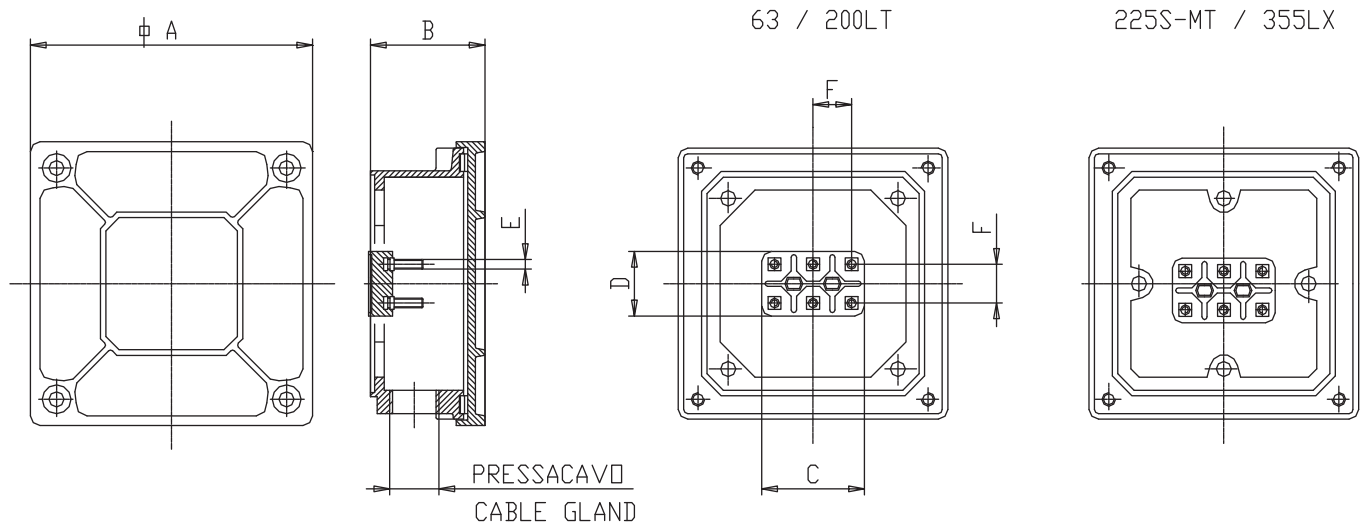

Motore tipo Motor type	A	B	C	D	E	F	Pressacavo Cable Gland
63	100,5	41	40	25	M4	15	M16x1.5
71	103	42	50	32	M4	18	M20x1.5
80							
90S-L	112	47	50	32	M4	18	M20x1.5
100	126	49	56	36	M5	20	M25x1.5
112MT-M	126	49	56	36	M5	20	M25x1.5
132S-M	152	66	70	45	M6	25	M25x1.5
160MT	170	82	70	45	M6	25	M32x1.5
160M-L	188	86	82	52	M8	30	M40x1.5
180MT-LT							
180L							
200LT	188	86	95	60	M8	35	M40x1.5
200L	225	103	95	60	M10	35	M50x1.5
225ST-MT							
250MT	225	103	115	70	M10	45	M50x1.5
280ST-MT	276	120	125	80	M12	45	M50x1.5
315ST							M63x1.5
315 M	375	145	145	90	M14	54	N.2 M63x1.5
355LT	375	145	165	100	M16	65	N.2 M63x1.5
355L	430	165	165	100	M16	65	N.2 M63x1.5
355Lx	430	165	165	100	M20	65	N.2 M63x1.5

I motori grandezza 400÷500 hanno la scatola coprimorsettiera in acciaio e possono avere 3 o 6 morsetti. Le scatole sono fornite con una piastra uscita cavi amovibile forata a cura del cliente.

• Motors size 400÷500 have steel terminal box and can have 3 or 6 terminals. The boxes are supplied with a removable cable outlet plate to be drilled by the customer.

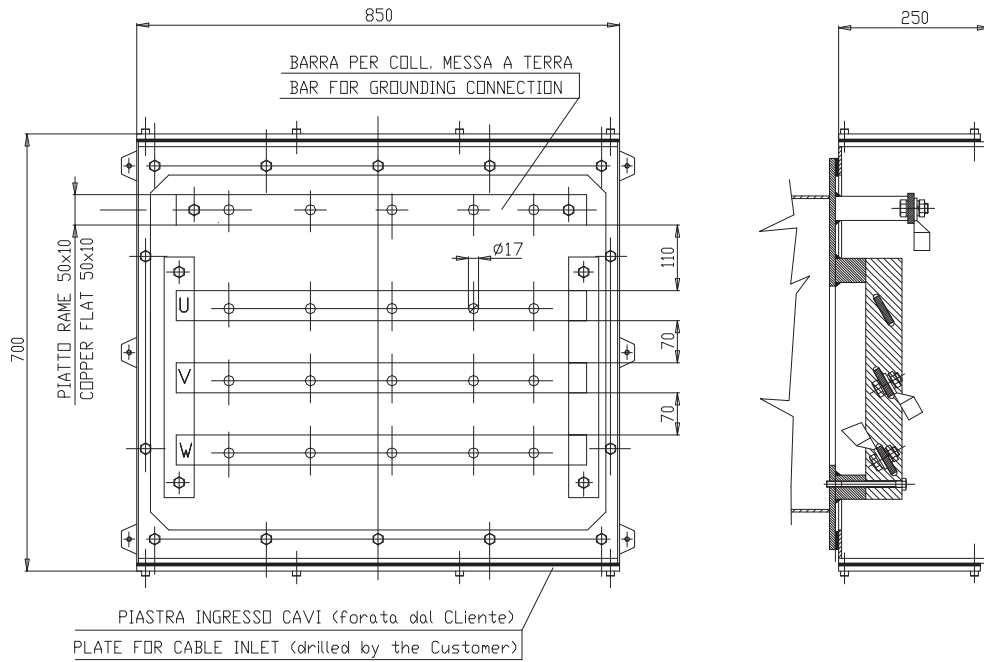

Morsetteria a 3 morsetti
Terminal block with 3 terminals

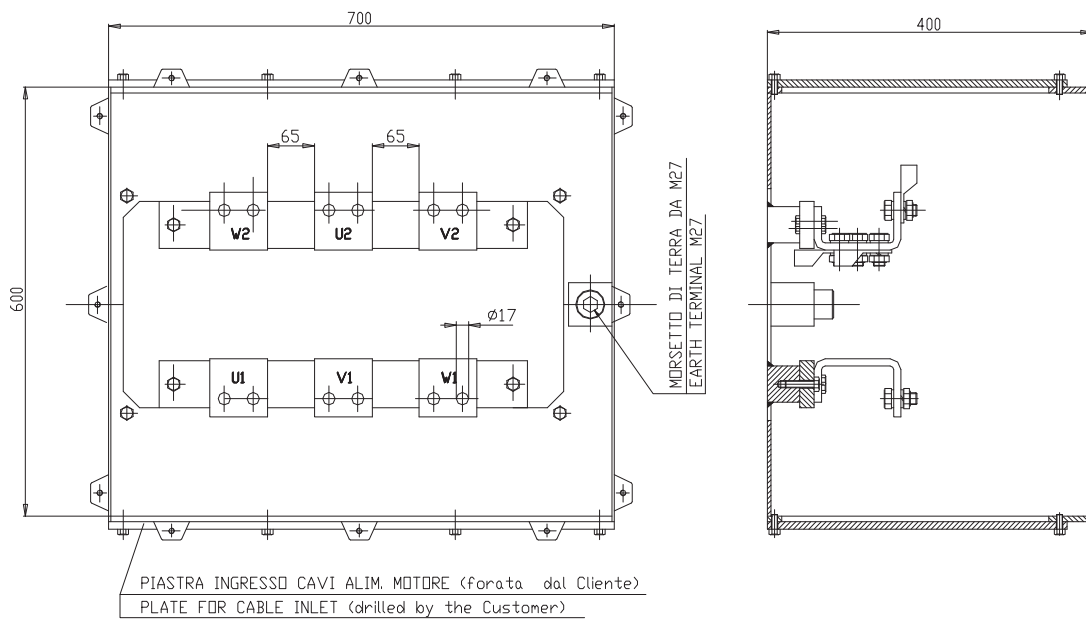

Morsetteria a 6 morsetti fornita con N. 3 piastre in rame per collegamento stella/triangolo
Terminal block with 6 terminals supplied with Nr. 3 copper plates for star/delta connection

Scatola morsetti ausiliari

I motori sono predisposti per il montaggio di scatole morsetti ausiliari con grado di protezione IP 55 o IP 56.

All'interno delle scatole morsetti trovano posto i collegamenti elettrici di eventuali accessori quali termoprotettori, termorivelatori, scaldiglie, encoder, ecc...

Le scatole morsetti ausiliari sono di 3 tipi in funzione alla grandezza del motore e al numero di collegamenti elettrici richiesti dal Cliente e possono essere in alluminio (fino alla grandezza 355Lx) oppure in acciaio (motori dal 400Lx al 500Lx).

Di seguito sono riportate le dimensioni d'ingombro.

Auxiliary terminal box

Motors are prepared for mounting auxiliary terminal boxes with IP 55 or IP 56 protection degree.

Inside the terminal boxes, the terminals for possible accessories such as thermal protections, thermal detectors, anticondensation heaters, etc... can be placed.

There are 3 types of auxiliary terminal boxes according to motor size and the number of electrical connections required by the Customer. They can be made of aluminium (up to size 355Lx) or steel (from 400Lx to 500Lx).

Hereunder are mentioned the overall dimensions.

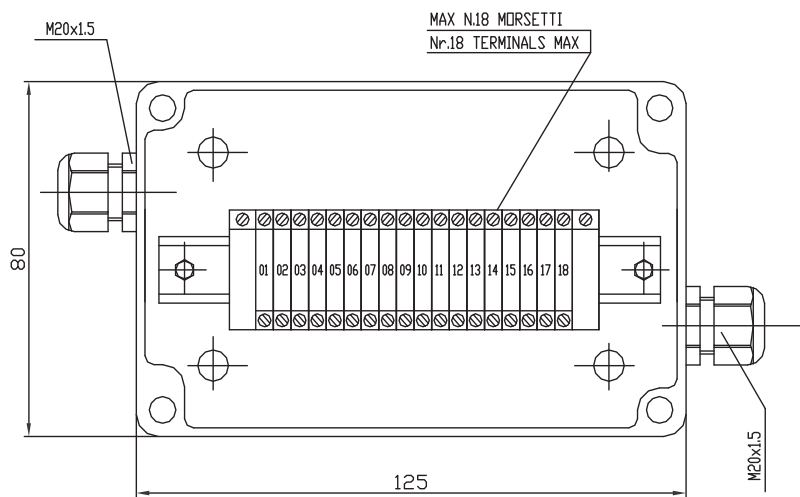

Scatola morsetti ausiliari in alluminio per motori dal 225T al 315M
Aluminium auxiliary terminal box; motor sizes from 225T to 315M

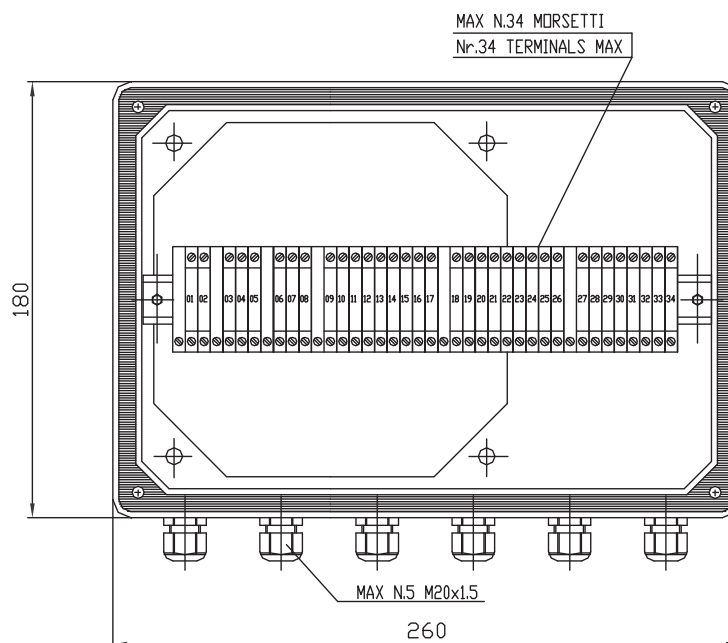

Scatola morsetti ausiliari in alluminio per motori dal 355L al 355Lx
Aluminium auxiliary terminal box; motor sizes from 355L to 355Lx

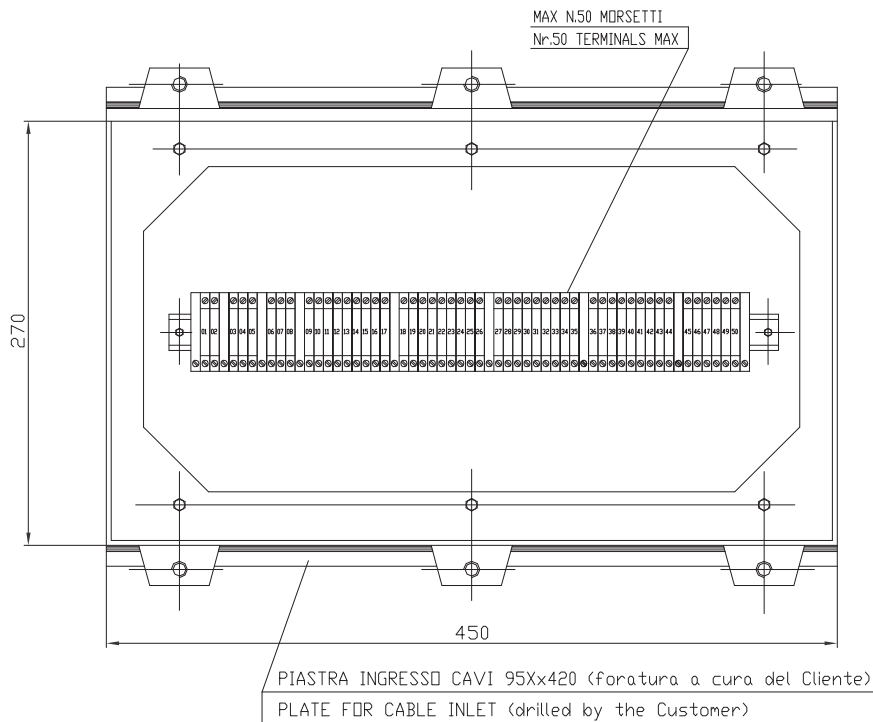

Scatola morsetti ausiliari in acciaio per motori dal 400Lx al 500Lx
Auxiliary steel terminal box; motor sizes from 400Lx to 500Lx

Gabbia di rotore

I motori di grandezza 63÷355 hanno normalmente il rotore realizzato in alluminio pressofuso.

I motori di grandezza 355Lx÷500 hanno le gabbie realizzate in rame/ottone saldato con processo T.I.G. o M.I.G. al fine di aumentare il rendimento delle macchine e ottimizzare le caratteristiche di avviamento.

Isolamento, avvolgimento

I motori serie C in esecuzione standard (IE1) sono realizzati in classe d'isolamento F; i motori serie C in esecuzione ad alta efficienza (IE2) sono realizzati in classe d'isolamento F con sovratemperatura di classe B.

Il conduttore in filo di rame elettrolitico ricotto è isolato con smalto speciale (doppio smalto), è classificato in classe di isolamento H.

Tutti i materiali isolanti utilizzati per la realizzazione dei motori sono corrispondenti alla classe d'isolamento F o H.

L'avvolgimento subisce un rigoroso trattamento consistente in un'impregnazione ad immersione con resine di classe F polimerizzanti a caldo.

A richiesta è possibile realizzare una tropicalizzazione comprendente a sua volta una spruzzatura di smalto antisalino e copertura finale, a spruzzo, con elevate caratteristiche di resistenza al calore, all'umidità, agli agenti chimici e all'azione corrosiva dell'ambiente marino.

Rotor cage

Motors with frame size 63÷355 have the rotor cage in die-cast aluminium.

Motors with frame size 355Lx÷500 have the rotor cage in copper/brass soldered using the T.I.G or M.I.G process in order to increase the electric machine efficiency and optimize starting characteristics.

Insulation, winding

C series motors in standard execution (IE1) are made in insulation class F; C series motors in high efficiency execution (IE2) are made in insulation class F with temperature rise in class B.

The soft copper electrolytic wire is insulated by using a special enamel (double enamel). Such enamel is classified as H insulation class.

All insulating materials used to produce motors are in F or H insulation class.

The winding undergoes a severe treatment as follows: it is impregnated by soaking it in oven-curing F class resins.

Upon request it is possible to make a tropicalization following a process including a spraying of anti-salty enamel and, finally, it is coated using a spray with heat-proof, humidity-proof, chemical agent and sea-ambient corrosive action resistant characteristics.

Potenza e dati tecnici

Le potenze ed i dati indicati nelle Tabelle "Dati Tecnici" sono riferiti al servizio continuo (S1), alla temperatura ambiente di 40°C, altitudine massima di 1.000 metri s.l.m., con tensione di alimentazione 400 V e frequenza 50 Hz. Le caratteristiche di funzionamento sono garantite con le tolleranze stabilite dalle norme CEI EN 60034-1 e le raccomandazioni IEC 60034-1, indicate nella tabella.

Ratings and technical data

Power and data mentioned in the Technical Data Tables are for continuous duty (S1) at an ambient temperature of 40°C, max. altitude 1.000 a.s.l., with supply at 400 V - 50 Hz. The operating characteristics are guaranteed with the tolerances defined by the CEI EN 60034-1 Standards and the IEC 60034-1 Recommendations, mentioned in table.

Caratteristiche - Characteristics	Tolleranza - Tolerances
Rendimento <i>Efficiency</i>	Macchine di potenza ≤150 kW: -15% di (1 - η) Macchine di potenza >150 kW: -10% di (1 - η) <i>Motor power ≤150 kW: -15% of (1 - η)</i> <i>Motor power >150 kW: -10% of (1 - η)</i>
Fattore di potenza <i>Power factor</i>	+1/6 (1 - cosφ) Minimo 0.02 Max 0.07 <i>+1/6 (1 - cosφ) Min 0.02 Max 0.07</i>
Corrente di spunto <i>Locked rotor current</i>	+20% del valore garantito <i>+20% of guaranteed value</i>
Coppia di spunto <i>Locked rotor torque</i>	-15%+25% del valore garantito <i>-15%+25% of guaranteed value</i>
Coppia massima <i>Pull out torque</i>	-10% del valore garantito <i>-10% of guaranteed value</i>
Scorrimento <i>Slip</i>	Macchine di potenza <1 kW: ±30% del valore garantito Macchine di potenza ≥1 kW: ±20% del valore garantito <i>Power motor <1 kW: ±30% of guaranteed value</i> <i>Power motor ≥1 kW: ±20% of guaranteed value</i>

Tensione di alimentazione - Collegamenti

I motori serie C grandezza 63÷280 possono essere realizzati per alimentazione a tensioni nominali comprese tra 220 V e 690 V a 50 Hz e a 60 Hz; i motori serie C grandezza 315÷500 possono essere realizzati per tensioni comprese tra 400 V e 690 V. Normalmente sono previsti per essere utilizzati per alimentazione a 230/400 V e 400/690 V o 690 V a 50 Hz.

In queste condizioni di alimentazione i rendimenti sono conformi ai requisiti indicati dalla Norma IEC 60034-30.

La tensione più bassa è realizzata con collegamento a triangolo mentre la tensione maggiore è ottenuta con collegamento a stella.

Ovviamente l'avviamento a stella-triangolo è possibile unicamente su una rete corrispondente alla tensione ottenibile con il collegamento a triangolo.

Supply voltage - Connections

C series motors frame size 63÷280 can be manufactured for supply at rated voltages included between 220 V and 690 V at 50 Hz and at 60 Hz; C series motors frame size 315÷500 can be manufactured for voltages included between 400 V and 690 V. They are normally designed to be used for supply at 230/400 V and 400/690 V or 690 V at 50 Hz.

In these supply conditions efficiencies are in compliance with the requirements of the IEC 60034-30 Standard.

The lower voltage is made with delta connection while the higher voltage is obtained with star connection.

Obviously the star delta starting is only possible on a mains corresponding to the voltage that can be obtained with the delta connection.

Oscillazioni di tensione e frequenza

I motori possono funzionare senza subire danni, se la tensione di alimentazione varia entro i limiti stabiliti dalle Norme di riferimento.

In particolare i motori possono funzionare con variazione di tensione del 10% e di frequenza del 5% con una variazione combinata massima del 10% con sovratemperatura conforme a quanto previsto dalle norme di riferimento.

Funzionamento multitemperatura e 60 Hz

I motori serie C possono funzionare con frequenza a 60 Hz con differenze di prestazione e grandezze elettriche che si ottengono applicando i coefficienti moltiplicativi indicati nella tabella seguente.

Voltage and frequency variations

Motors can work without failures if the supply voltage variations are limited as stated in the reference Standards.

In particular, motors can run with voltage variations of 10% and frequency variations of 5% with a maximum combined variation of 10% with temperature rise in compliance with the provisions of the reference Standards.

Operation at different voltages and 60 Hz

C series motors can run with a frequency of 60 Hz with differences in performances and electrical data, that can be obtained by applying the multiplicative coefficients shown in the following table.

Tensione di targa <i>Nominal voltage</i>	Tensione di targa <i>Nominal voltage</i>	Potenza nom. <i>Nominal power</i>	Corrente nom. <i>Nominal current</i>	Coppia nom. <i>Nominal torque</i>	Giri/min <i>rpm</i>	Corrente di spunto <i>Starting current</i>	Coppia di spunto <i>Starting torque</i>	Coppia max <i>Max torque</i>
230+/-10%	220+/-5%	1	1	0.83	1.2	0.83	0.83	0.83
230+/-10%	230+/-10%	1	0.95	0.83	1.2	0.83	0.83	0.83
230+/-10%	254+/-5%	1.15	1.02	0.96	1.2	0.93	0.93	0.93
230+/-10%	277+/-5%	1.2	1	1	1.2	1	1	1
400+/-10%	380+/-5%	1	1	0.83	1.2	0.83	0.83	0.83
400+/-10%	400+/-10%	1	0.95	0.83	1.2	0.83	0.83	0.83
400+/-10%	440+/-5%	1.15	1.02	0.96	1.2	0.93	0.93	0.93
400+/-10%	460+/-10%	1.15	1	0.96	1.2	0.96	0.96	0.96
400+/-10%	480+/-5%	1.2	1	1	1.2	1	1	1
690 V		Contattare Electro Adda - Contact Electro Adda						

Declassamenti

Le tabelle dei dati tecnici sono riferite alla temperatura ambiente max 40°C ed altitudine fino a 1.000 metri s.l.m.

Per condizioni ambientali diverse, le potenze variano e si ottengono applicando i fattori correttivi indicati nella tabella, mantenendo le sovratemperature previste per la classe d'isolamento.

Deratings

The tables of technical data are referred to an ambient temperature of 40°C and an altitude up to 1.000 m.a.s.l.

In different environmental conditions output ratings vary, and are obtainable by applying the factors as mentioned in table, maintaining the temperature rise provided for by the insulation class.

Altitudine m.s.l.m. Altitude m.a.s.l.	Temperatura ambiente (°C) - Ambient temperature (°C)					
	30	40	45	50	55	60
<= 1000	1.06	1	0.97	0.94	0.90	0.87
1500	1.04	0.97	0.94	0.91	0.87	0.84
2000	1	0.95	0.92	0.88	0.84	0.81
3000	0.96	0.89	0.86	0.82	0.78	0.74
4000	0.91	0.84	0.80	0.76	0.72	0.67

Servizi

I dati tecnici riportati nelle tabelle sono riferiti al servizio continuo (S1). A richiesta possono essere forniti motori per Servizio limitato S2 (30 o 60 minuti) o per altri tipi di servizio

Duties

All technical data mentioned in the tables are referred to continuous duty (S1). Upon request, motors for limited Duty S2 (30 or 60 minutes) or for other duties can be supplied.

Sovraccarichi

I motori in servizio continuo possono sopportare i seguenti sovraccarichi:

Overloads

Continuous duty motors can withstand the following overloads:

Sovraccarico - Overload %	Durata - Duration Min.	Intervallo - Interval Min.
10	10	15
20	6	15
30	4	15
40	3	15
50	2	15

In tali condizioni di funzionamento in sovraccarico, le sovratemperature possono risultare superiori di 10°C ai limiti previsti per la classe d'isolamento.

Per i motori in classe energetica IE2 e IE3 con i sovraccarichi sopraindicati le sovratemperature restano entro i limiti della classe d'isolamento F.

In such operation conditions with overload, temperature rises may be 10°C higher than the limits provided for by the insulation class.

For motors in IE2 and IE3 energy class with the above mentioned overloads, temperature rises remain within the limits of the F insulation class.

Avviamenti

I motori sono idonei per i seguenti tipi di avviamento:

- Diretto
- Stella - triangolo
- Autotrasformatore
- Soft-start⁽¹⁾
- Con inverter

1) Al termine dell'avviamento il soft-starter deve essere by-passato. In caso contrario è necessario utilizzare un motore con avvolgimento con isolamento rinforzato.

Rumorosità

Le tabelle dei dati tecnici riportano i valori di rumorosità (LpA) e in potenza (LwA) sonora misurati ad un metro di distanza espressi in dB(A).

I valori di rumorosità sono rilevati con motore funzionante a vuoto e con una tolleranza di 3 dB(A).

Vibrazioni

I motori sono bilanciati dinamicamente con mezza chiave applicata all'estremità d'albero secondo la norma IEC 60034-14 e hanno grado di vibrazione A in esecuzione standard.

La seguente tabella indica i limiti raccomandati dell'intensità di vibrazione per le varie altezze d'asse.

Vibrazioni più elevate possono verificarsi sul motore installato sull'impianto, a causa di vari fattori come basamenti non adeguati o reazioni da parte del sistema azionato. In questi casi, verifiche più approfondite dovrebbero essere eseguite su ogni parte componente l'installazione.

Startings

Motors are suitable for the following types of starting:

- Direct
- Star - delta
- By autotransformer
- Soft-start⁽¹⁾
- By inverter

1) At the end of the starting, the soft-starter must be by-passed. If not, it is necessary to use a motor with winding with reinforced insulation.

Noise

The technical features table contains the values of A-sound pressure level (LpA) and A sound power level (LwA), measured at a one meter distance.

Sound levels are measured in no-load conditions and have tolerances of 3 dB(A),

Vibrations

Motors are dynamically balanced with a half key applied to the shaft extension in accordance with the IEC 60034-14 standard to vibration severity grade A in standard execution.

The following table shows the maximum vibration grades with respect to the different frame sizes.

Larger vibrations may occur on motors installed at site, due to various factors such as unsuitable foundations or reactions caused by the driven load. In such cases checks should also be carried out on each element of the installation.

Grado Equilibratura Vibration grade	Montaggio Mounting	Altezza d'asse - Frame size 56≤H≤132			Altezza d'asse - Frame size 132<H≤280			Altezza d'asse - Frame size >280		
		Spostam Displac. µm	Velocità Speed mm/s	Acc. Acc. m/sec ²	Spostam Displac. µm	Velocità Speed mm/s	Acc. Acc. m/sec ²	Spostam Displac. µm	Velocità Speed mm/s	Acc. Acc. m/sec ²
A	Sospensione libera Free suspension	25	1.6	2.5	35	2.2	3.5	45	2.8	4.4
	Montaggio rigido Rigid mounting	21	1.3	2	29	1.8	2.8	37	2.3	3.6
B	Sospensione libera Free suspension	11	0.7	1.1	18	1.1	1.7	29	1.8	2.8
	Montaggio rigido Rigid mounting	-	-	-	14	0.9	1.4	24	1.5	2.4

Protezioni termiche

A richiesta sui motori serie C è possibile installare le seguenti protezioni termiche:

Termistori PTC

Alla temperatura d'intervento questo dispositivo varia repentinamente la resistenza standard.

Generalmente la protezione è realizzata con tre elementi sensibili, uno per fase, collegati in serie e con i due terminali in un'apposita morsettiera posta all'interno della scatola morsetti o in un'apposita scatola morsettiera ausiliaria.

Protettori bimetallici

Motoprotettori con contatto normalmente chiuso. Il contatto si apre quando la temperatura degli avvolgimenti raggiunge limiti pericolosi per il sistema isolante.

Sensori di temperatura a resistenza di platino PT100

Il valore di resistenza varia linearmente con la temperatura degli avvolgimenti. Dispositivo particolarmente adatto per un rilievo continuo della temperatura.

Scaldiglie anticondensa

Per i motori funzionanti in ambienti ad elevata umidità e con forti escursioni termiche si consiglia l'applicazione di scaldiglie per eliminare la condensa.

Sono di tipo a nastro e vengono montate sulla testata degli avvolgimenti di statore.

Viene normalmente prevista la loro alimentazione quando quella del motore viene interrotta, generando un riscaldamento che previene la formazione di condensa.

La tensione di alimentazione normale è 115 V o 220/240 V.

I terminali delle scaldiglie sono portati ad un'apposita morsettiera posta all'interno della scatola morsetti principale. A richiesta possono essere portati ad una morsettiera posta in una scatola morsetti ausiliari.

Le potenze normalmente impiegate sono indicate nella tabella seguente.

Thermal protections

Upon request, the following thermal protections can be installed on the C series motors:

Positive temperature coefficient thermistors PTC

At the active temperature this device quickly changes its standard resistance value.

The protection is normally made by 3 sensitive elements, one for every phase, series connected and with two terminals in a specially provided terminal board located in the main terminal box or in a specially provided auxiliary terminal box.

Bimetallic devices

Motoprotectors with normally closed contact. The contact opens when the winding temperature reaches limits dangerous to the insulation system of the motor.

Platinum resistance thermal detector PT100

Variable linear resistance with the winding temperature. Device particularly suitable for a continuous winding temperature monitoring.

Anticondensation heaters

Motors subject to atmospheric condensation, either through standing idle in damp environments or because of wide ambient temperature variations, may be fitted with anticondensation heaters.

They are of tape form and are normally mounted on the stator winding head.

Anticondensation heaters are normally switched on automatically when the supply to the motor is interrupted, heating the motor to avoid water condensation.

Normal supply voltage is 115 V or 220/240 V.

Anticondensation heater terminals are led to a specially provided terminal board located in the main terminal box. Upon request they can be led to a terminal board located in an auxiliary terminal box.

The power values normally used are shown in the following table.

Altezza d'asse - Frame size	Potenza (W) - Power (W)
132÷160	40
180÷200	45
225÷250	50
280÷315	100
355	200
400	300
450	400
500	500

Tappi scarico condensa

I motori serie CS grandezza 355L÷500 sono normalmente forniti di tappi posti sulla carcassa (forme B3 e derivate) o sugli scudi (forma V1) per poter scaricare la condensa che si può formare all'interno del motore.

Sui motori serie CA grandezza 63÷355LT i fori scarico condensa sono realizzabili a richiesta.

I motori sono forniti con i fori di scarico condensa chiusi e tali devono rimanere per garantire il grado di protezione (IP) richiesto.

In funzione delle condizioni operative di funzionamento è necessario che periodicamente tali tappi vengano aperti per permettere lo scarico della condensa.

Viteria inox

I motori della serie C possono essere forniti, per installazione in ambienti aggressivi, con viteria inox o trattata con procedimenti specifici (galvanizzazione, zincatura, ecc...)

Verniciatura - Cicli speciali

ELECTRO ADDA ha definito un certo numero di cicli di verniciatura in funzione delle condizioni ambientali e climatiche in cui i motori vengono installati:

- Ciclo standard
- Ciclo intermedio
- Ciclo speciale

Ciclo standard

Ciclo di verniciatura che prevede l'utilizzo di vernici a base acqua, eliminando completamente l'utilizzo di solventi.

L'applicazione viene effettuata con braccio robotizzato abbinato ad un sistema automatico di rotazione bidirezionale programmata.

Il sistema di applicazione della vernice, completamente automatico, ha la possibilità di variare i seguenti colori: Grigio Pietra RAL 7030 (colore standard), Blu Genziana RAL 5010, Verde Reseda RAL 6011, Bianco RAL 9002, Azzurro RAL 5012, Nero RAL 9005.

Altri colori sono possibili, con supplemento di prezzo.

Questo ciclo di verniciatura è adatto a motori installati in normali ambienti industriali, con umidità ≤75% e liberi da agenti salini, chimici, aggressivi.

Ciclo intermedio

Ciclo di verniciatura che prevede l'utilizzo di prodotti bicomponente formulati con l'impiego di resine epossidiche solide e resine viniliche

Condensation drainage plugs

CS series motors frame size 355÷500 are normally provided with plugs placed on the frame (mountings B3 and derived mountings) or on the shields (mounting V1) in order to drain condensation that can form inside the motor.

CA series motors frame size 63÷355LT can be provided with condensation drainage holes upon request.

Motors are supplied with closed condensation drainage holes, they must remain closed to guarantee the required protection degree (IP).

Based on the operating conditions it is necessary to periodically open the plugs to allow condensation drainage.

Stainless steel screws and bolts

C series motors can be supplied, when installed in aggressive environments, with stainless steel or specifically treated (galvanizing, annealing, etc...) screws and bolts.

Painting - Special cycles

ELECTRO ADDA has defined a number of painting cycles depending on climatic and environmental conditions in which the motors are installed:

- Standard cycle
- Intermediate cycle
- Special Cycle

Standard cycle

Painting cycle that includes the use of water-based paints, completely eliminating the use of solvents.

The application is carried out with a robotic arm coupled to an automatic system for a programmed bidirectional rotation.

The application system of the paint, fully automatic, has the possibility to vary the following colors: Stone Grey RAL 7030 (standard color), Gentian Blue RAL 5010; Reseda Green RAL 6011, White RAL 9002, Blue RAL 5012, Black RAL 9005.

Other colors are possible, with additional charge.

This painting cycle is suitable for motors installed in normal industrial environments, humidity ≤75% and free from toxic, chemicals, aggressive substances.

Intermediate cycle

Painting cycle that involves the use of two-component products made with the use of solid epoxy resins and vinyl resins crosslinked polyamide

reticolate con catalizzatore poliammidico che garantisce una eccellente adesione ed una elevata resistenza chimica e fisica.

I colori finali disponibili sono RAL 7030 (colore standard), RAL 5010, RAL 6011, RAL 9003, RA L9005. Altri colori disponibili a richiesta in sede di offerta.

Questo ciclo di verniciatura è adatto a motori installati in ambienti leggermente aggressivi, umidi-salini (bordo mare).

Ciclo speciale

Ciclo di verniciatura che prevede l'utilizzo di due mani di fondo con vernici a base epossivinilica e smalti di finitura a base poliuretana, Il colore finale è a scelta del Cliente.

Questo ciclo di verniciatura è adatto a motori che devono essere impiegati in ambienti marini, navali, debolmente acidi e chimici.

Le schede tecniche delle vernici utilizzate sono disponibili su richiesta.

Oltre ai cicli su descritti, sono disponibili i cicli di verniciatura secondo la Norma ISO12944-1, tenendo presente che questa norma è relativa a superfici in acciaio, mentre i motori della serie CA hanno la carcassa in alluminio.

La necessità di un ciclo di verniciatura diverso dallo standard deve essere segnalata dal Cliente già in fase di offerta.

L'Ufficio Tecnico di **ELECTRO ADDA** è a disposizione per definire assieme al Cliente il ciclo di verniciatura più appropriato all'applicazione, ma è comunque responsabilità del Cliente accertarsi che il ciclo prescelto sia adatto alle Sue necessità.

In mancanza di indicazione contraria, i motori sono verniciati secondo il ciclo standard, con colore finale grigio RAL 7030.

with a catalyst which ensures excellent adhesion and a high chemical and physical resistance.

Available final colors are: RAL 7030 (standard color), RAL 5010, RAL 6011, RAL 9003, RAL 9005. Other colors available on request when inquiring.

This painting system is suitable for motors installed in slightly aggressive environments, moisture, salt (sea side).

Special cycle

Painting cycle that includes the use of two coats of epoxy-based paints and enamels finishing based on polyurethane. The final color is chosen by the customer.

This painting cycle is suitable for motors that must be employed in marine, naval, slightly acidic and chemical environments.

Technical specifications of the used paints are available upon request.

In addition to the cycles described above, painting cycles according to ISO12944-1 Standards are also available, bearing in mind that this Standards is related to the steel surfaces, while the CA series motors have Aluminum body.

The need for a painting cycle different from the standard must be reported by the customer since the inquiry.

*The Technical Department of **ELECTRO ADDA** is available together with the customer to define the most appropriate painting cycle to the application, but it is its responsibility to ensure that the chosen cycle is suitable to its needs*

If no indication is given, motors are painted according to the standard cycle, with final color gray RAL 7030.

Ciclo di verniciatura <i>Painting cycle</i>	Ambiente <i>Environment</i>	Applicazione	Application
Standard <i>Standard</i>	Industriale, non aggressivo <i>Industrial, not aggressive</i>	1 mano a spruzzo di smalto con legante alchidico a base di acqua Gloss 40-50 (semilucido) Spessore medio 35µ	1 spray coat of enamel with water-based alkyd binder Gloss 40-50 (semigloss) Average thickness 35µ
Intermedio <i>Intermediate</i>	Umido-salino, bordo mare, leggermente aggressivo <i>Humid-salty, seaside, slightly aggressive</i>	1 mano di fondo intermedio epossivinilico 1 mano di smalto di finitura poliuretano acrilica Gloss 40-50 semiopaco Spessore medio 60µ	1 epoxy-vinyl intermediate coat 1 polyurethane acrylic enamel finishing coat Gloss 40-50 (semimatt) Average thickness 60µ
Speciale <i>Special</i>	Aggressivo, marino, navale, debolmente acido e chimico <i>Aggressive, sea, naval, slightly acid and chemical</i>	2 mani di fondo epossivinilico bicomponente a rapida essiccazione 1 mano di smalto di finitura poliuretano bicomponente Gloss 50-60 semilucido Spessore medio 150µ	2 two-components epoxy-vinyl with fast drying primer coat 1 two-components polyurethane enamel finishing coat Gloss 50-60 (semigloss) Average thickness 150µ
Su specifica Cliente <i>On Customer request</i>	-	-	-
Norma / Standards ISO 12944-1	-	Per superfici in lamiera, ghisa e acciaio	For metal, cast iron and steel surfaces

Oltre a questi cicli, **ELECTRO ADDA** ha definito un ciclo di verniciatura per Applicazioni Ferroviarie, che risponde alle esigenze imposte dalle Normative di Settore per macchine sottoposte a severe sollecitazioni meccaniche ed ambientali.

I prodotti utilizzati e la preparazione delle superfici garantiscono l'idoneità dei motori a:

- Temperatura di stoccaggio $-25^{\circ}\text{C}:+85^{\circ}\text{C}$
- Temperatura di esercizio $-25^{\circ}\text{C}:+70^{\circ}\text{C}$
- Umidità 100%
- Resistenza al freddo -25°C -72h secondo la norma CEI EN 60068-2-14
- Nebbia Salina Ciclica grado di severità 3 (7 giorni) secondo la norma CEI EN 60068-2-52
- Resistenza al cambio di temperatura $-25^{\circ}\text{C} +85^{\circ}\text{C}$ secondo la norma CEI EN 60068-2-14

Spessore medio totale 120 μ .

Freni

I motori della serie CA grandezza 63÷315 descritti nel presente catalogo possono essere forniti completi di freno elettromagnetico a disco, montato sul retro del motore, sia in corrente continua (serie FECC - FECCL) che in corrente alternata (serie FE).

Riferirsi all'apposito catalogo.

Prove e collaudi

Prove di routine

Tutti i motori prodotti da **ELECTRO ADDA** vengono sottoposti a controlli mediante apparecchiature apposite che verificano tutta la produzione del Reparto Avvolgimenti e del Reparto Assemblaggio con prove dedicate all'aspetto Elettromagnetico sia di potenza che di isolamento.

Le macchine vengono inoltre sottoposte alla verifica scariche parziali a mezzo di specifica apparecchiatura che, in accordo alla norma TS 60034-18-41 verifica la qualità del filo di rame utilizzato, degli isolanti e del sistema di impregnazione.

Prove di tipo

Le prove di tipo vengono effettuate sui prototipi, su motori campione presi dalla linea di produzione, sui motori sottoposti a certificazioni varie (es. Rina, LR, DNV, ecc...) o su specifica richiesta del cliente.

Le prove di tipo sono realizzate con motore assemblato presso la sala prove di **ELECTRO ADDA**.

Le prove sono eseguite secondo le Norme CEI-IEC 60034.

Collaudi presenziati

L'esecuzione di collaudi presenziati con l'inviato del Cliente deve essere concordata in sede di offerta e di ordine.

*In addition to the above cycles, **ELECTRO ADDA** has defined a painting cycle for Railway Applications, which meets the requirements imposed by the Regulations of Industrial Machines subjected to severe mechanical and environmental stresses.*

Products used and the preparation of the surfaces ensure the suitability of motors for:

- Storage temperature $-25^{\circ}\text{C}:+85^{\circ}\text{C}$
- Operating temperature $-25^{\circ}\text{C}:+70^{\circ}\text{C}$
- Humidity 100%
- Cold resistance -25°C -72 hours in accordance with IEC 60068-2-14
- Cyclic Salt Spray degree of severity 3 (7 days) according to IEC 60068-2-52
- Resistance to change of temperature -25°C to $+85^{\circ}\text{C}$ according to IEC 60068-2-14

Total average thickness 120 μ .

Brakes

Motors sizes 63÷315 described in this catalog can be supplied complete with an electromagnetic disc brake mounted on the rear of the motor, both dc (FECC - FECCL Series) and ac (FE Series).

Please refer to the relevant catalog.

Tests and controls

Routine tests

*All motors manufactured by **ELECTRO ADDA** are checked by special equipment that occur throughout the production department of the windings and the Assembly Department with tests dedicated to the Electro-magnetic aspects both for power and insulation.*

Machines are also subjected to the partial discharge tests by means of specific equipment which, according to the standard TS 60034-18-41, verifies the quality of the copper wire used, the insulations and the impregnation system.

Type tests

Type tests are carried out on prototypes, sample motors taken from the production line, motors tested with various certification bodies (eg, Rina, LR, DNV, etc...) or at the specific request of the Customer.

*Type tests are carried out with the motor assembled at the **ELECTRO ADDA** testing room.*

Tests carried out in accordance with CEI-IEC 60034-1.

Witnessed tests

Witnessed tests must be agreed in the offer and order.

Trasduttori di velocità (encoder)

Sui motori della serie C è possibile montare un generatore di impulsi (encoder).

ELECTRO ADDA ha scelto la soluzione con albero cavo, per avere una maggiore compattezza e garantire l'ottimale fissazione meccanica con l'albero del motore.

Gli encoder standard sono:

Leine & Linde RHI 594 per le grandezze ≤ 315

Leine & Linde 861 per le grandezze ≥ 355

Le caratteristiche degli encoder standard sono riassunte nelle tabelle seguenti.

Speed transducers (encoder)

C Series motors can be supplied with a pulse generator (encoder).

ELECTRO ADDA has selected the hollow shaft solution, to get a better compactness and to guarantee the optimal mechanical fixation with the motor shaft.

Standard encoders are:

Leine & Linde RHI 594 type for frames ≤ 315

Leine & Linde 861 type for frames ≥ 355

Standard encoders main features are summarized on the following tables.

RHI 594 - Dati elettrici - <i>Electrical data</i>			
Alimentazione <i>Power supply</i>	5 Vcc	9-30 Vcc	
Segnali di uscita <i>Output signals</i>	TTL	HTL	RS-422
Consumo di corrente <i>Current consumption</i>	45 mA	50 mA @ 24 Vdc	25 mA @ 24 Vdc
Consumo massimo <i>Max consumption</i>	75 mA	75 mA	40 mA
Carico massimo <i>Output load max</i>	± 20 mA	± 40 mA	± 20 mA
Lunghezza massima cavi <i>Max cables length</i>	50 m	200 m @ 50 Hz	1 km (TIA/EIA-422-B)
Soglia logica alta @ 10mA di carico <i>V_{high} at 10mA load</i>	>3.0 V	>+EV - 2,0 V	>3.0 V
Soglia logica bassa @ 10mA di carico <i>V_{low} at 10mA load</i>	<0.4 V	<1.15 V	0.4 V
Impulsi per giro <i>Pulse per rpm</i>	1 ÷ 5.000 ppr		
Passi di misura <i>Measuring steps</i>	4 x linea di conteggio 4 x line count		
Accuratezza <i>Accuracy:</i> - Errore di divisione - <i>Dividing error</i> - Separazione canali - <i>Channels separation</i>	$\pm 50^\circ$ el $90^\circ \pm 25^\circ$ el		
Range di frequenza <i>Output frequency</i>	0 ÷ 300 kHz		

RHI 594 - Dati meccanici - <i>Mechanical data</i>	
Albero in acciaio inox <i>Stainless steel shaft</i>	Ø 12 mm albero cavo <i>Hollow shaft</i>
Carico massimo sull'albero <i>Max shaft load</i> - Radiale - <i>Radial</i> - Assiale - <i>Axial</i>	60 N 50 N
Velocità massima meccanica <i>Max mechanical speed</i>	6.000 g/1' / rpm
Temperature <i>Temperatures:</i> - Operativa - <i>Operating</i> - Immagazzinamento - <i>Storage</i>	-20°C ÷ +100°C -40°C ÷ +100°C
Carcassa <i>Cover</i>	Alluminio anodizzato <i>Anodized aluminium</i>
Peso <i>Weight</i>	Ca 300 gr
Grado di protezione <i>Degree of protection</i>	IP 67 secondo / <i>according IEC 60259</i> IP 66 in entrata albero / <i>At shaft inlet</i>
Vibrazioni massime <i>Max vibrations</i>	<300 m/sec ² (55 ÷ 2.000 Hz)
Shock <i>Shock</i>	<2.000 m/s ² (6 ms)
Cavo <i>Cable</i>	TPE/PUR 5x2x0,25mm ²

È possibile fornire l'encoder con cappuccio di isolamento elettrico dell'alberino.

• It is possible to supply the encoder together with a shaft cover for the electrical insulation from the shaft itself.

861 - Dati elettrici - <i>Electrical data</i>		
Alimentazione <i>Power supply</i>	5 Vcc ± 10%	9-30 Vcc
Segnali di uscita <i>Output signals</i>	RS-422	High current HTL
Consumo di corrente <i>Current consumption</i>	85 mA	60 mA @ 24 Vdc
Consumo massimo <i>Max consumption</i>	155 mA	80 mA
Carico massimo <i>Output load max</i>	±20 mA	±40 mA
Lunghezza massima cavi <i>Max cables length</i>	1 km (TIA/EIA-422-B)	350 m @ 100 Hz
Soglia logica alta @ 40mA di carico <i>V_{high} at 40mA load</i>	>3.0 V	>+EV - 4.0 V
Soglia logica bassa @ 40mA di carico <i>V_{low} at 40mA load</i>	<1.15 V	<2.5 V
Impulsi per giro <i>Pulse per rpm</i>	1000,1024,2048,200,3072,4096,5000ppr	
Passi di misura <i>Measuring steps</i>	4 x linea di conteggio <i>4 x line count</i>	
Accuratezza <i>Accuracy:</i> - Errore di divisione - <i>Dividing error</i> - Separazione canali - <i>Channels separation</i>	±50° el 90°±25° el	
Range di frequenza <i>Output frequency</i>	0÷200 kHz	0÷100 kHz

861 - Dati meccanici - <i>Mechanical data</i>	
Albero in acciaio inox <i>Stainless steel shaft</i>	Ø 12 mm albero cavo <i>Hollow shaft</i>
Carico massimo sull'albero <i>Max shaft load</i> - Radiale - <i>Radial</i> - Assiale - <i>Axial</i>	60 N 50 N
Velocità massima meccanica <i>Max mechanical speed</i>	6.000 g/1' / <i>rpm</i>
Temperature <i>Temperatures:</i> - Operativa - <i>Operating</i> - Immagazzinamento - <i>Storage</i>	-20°C ÷ +100°C -40°C ÷ +100°C
Carcassa <i>Cover</i>	Alluminio anodizzato <i>Anodized aluminium</i>
Peso <i>Weight</i>	Ca 300 gr
Grado di protezione <i>Degree of protection</i>	IP 67 secondo / <i>according IEC 60259</i> IP 66 in entrata albero / <i>At shaft inlet</i>
Vibrazioni massime <i>Max vibrations</i>	<300 m/sec ² (55 ÷ 2.000 Hz)
Shock <i>Shock</i>	<2.000 m/s ² (6 ms)
Cavo <i>Cable</i>	TPE/PUR 5x2x0,25 mm ²

A partire dalla grandezza 180 è possibile montare una protezione meccanica per proteggere l'encoder da urti accidentali (motori IC 411).

È possibile montare altri tipi di encoder, previo controllo dell'ufficio tecnico di **ELECTRO ADDA** in sede di offerta.

L'encoder può essere montato sia sui motori con ventilazione IC 411 che su quelli con ventilazione IC 416.

From size 180 a mechanical protection to protect the encoder from accidental bumps can be mounted (IC 411 motors).

*Other type of encoder are possible, previous a check of **ELECTRO ADDA** technical office when offering*

Encoder can be mounted both on motors IC 411 and IC 416 cooling system.

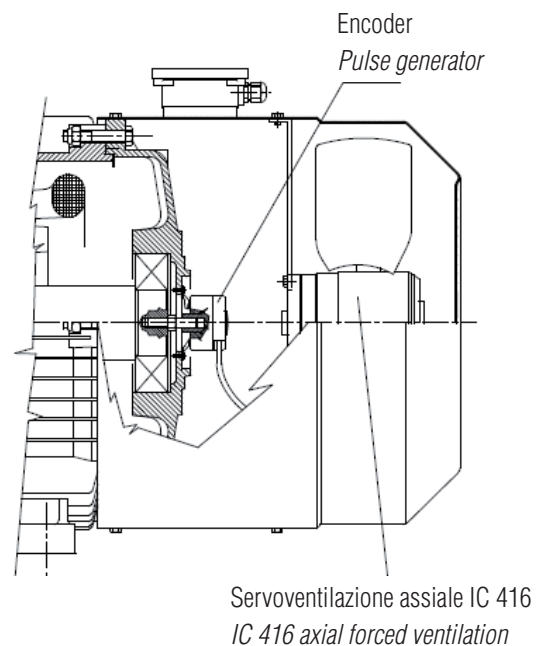
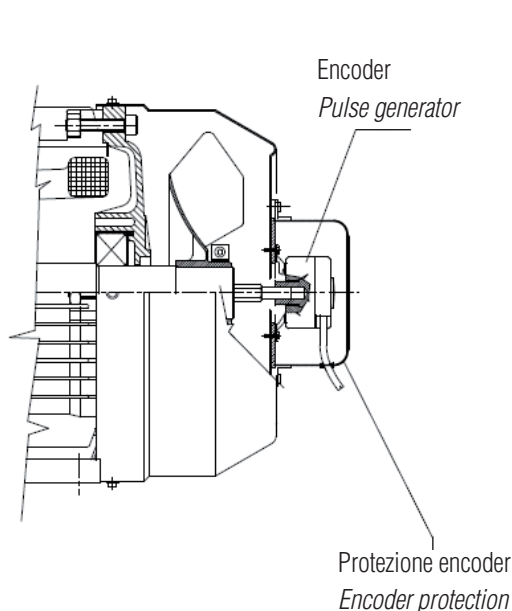

Dati tecnici

Classe di efficienza IE1 (IEC 60034-30; 2008)
Isolamento classe F - Servizio S1 - 400 V - 50 Hz
2 poli - 3.000 giri/min

Technical data

IE1 Efficiency class (IEC 60034-30; 2008)
Insulation class F - S1 Duty - 400 V - 50 Hz
2 poles - 3.000 rpm

Tipo Type	Potenza Power	Velocità Speed	J	Rend. Eff.	Fattore di potenza Power factor	Corrente Current In (400 V)	Coppia nom. Nominal torque	Coppia di spunto Starting torque	Corrente di spunto Starting current	Coppia massima Max torque	Rumor. Noise	Forma B3 Mount B3 Peso Weight
	kW	giri/min rpm	kgm ²	%	cosφ	A	Nm	Ca/Cn Tst/Tn	Ia/In Ist/In	Cmax/Cn Tmax/Tn	dB (A)	kg
Serie CA (carcassa in alluminio) - CA Series (aluminium frame)												
CA 63-a	0.18	2680	0.0002	64	0.75	0.54	0.641	2.4	3.5	2.5	57	3.3
CA 63-b	0.25	2700	0.0002	64	0.75	0.75	0.884	2.4	3.5	2.5	57	3.8
CA 71-a	0.37	2800	0.0004	71	0.8	0.94	1.262	2.2	4	2.3	59	6
CA 71-b	0.55	2810	0.0005	71	0.8	1.4	1.869	2.5	4.6	2.6	59	7
C1A 80-a	0.75	2820	0.0012	76	0.81	1.8	2.54	2.3	4.5	2.4	63	8.6
C1A 80-b	1.1	2820	0.0017	76.2	0.81	2.6	3.72	2.3	4.8	2.4	63	10.2
C1A 90S	1.5	2840	0.0012	78.5	0.8	3.4	5.04	2.4	4.9	2.5	68	11.5
C1A 90L	2.2	2840	0.0019	81	0.78	5	7.4	2.4	4.9	2.5	68	13.5
C1A 100L	3	2850	0.0032	82.6	0.81	6.4	10.1	2.6	6.5	2.8	72	20.5
C1A 112MT-a	4	2860	0.0042	84.2	0.8	8.6	13.4	2.6	6.5	2.8	72	23
C1A 112MT-b	5.5	2880	0.0055	83.5	0.84	11.3	18.2	2.5	7	2.8	72	28.2
C1A 132S-a	5.5	2900	0.009	85.7	0.85	10.9	18.1	2.5	7	2.8	74	38.4
C1A 132S-b	7.5	2900	0.0113	87	0.85	14.7	24.7	2.5	7	2.8	74	42
C1A 132M	9	2910	0.015	86	0.86	17.6	29.5	2.4	7	2.7	74	47.5
C1A 160MT-a	11	2910	0.017	88.4	0.84	21	36.1	2.5	6.5	2.7	74	58
C1A 160MT-b	15	2930	0.023	89.4	0.85	29	48.9	2.6	6.7	2.8	75	68
C1A 160L	18.5	2940	0.043	90	0.85	35	60.1	2.6	6.9	2.8	75	90
C1A 180MT	22	2950	0.051	90.5	0.85	42	71.2	2.7	7	2.9	75	110
C1A 180LT	25	2950	0.059	89.5	0.86	47	80.9	2.7	7	2.9	75	116
C1A 200LT-a	30	2950	0.089	91.4	0.86	55	97	2.7	7.3	3	83	142
C1A 200LT-b	37	2960	0.111	92	0.86	68	119	2.7	7.3	3	83	162
C1A 225MT	45	2960	0.18	92.5	0.86	82	145	2.7	7.5	3	83	210
C1A 250MT	55	2970	0.283	93	0.87	98	177	2.8	7.6	3	83	280
C1A 280ST	75	2970	0.493	93.6	0.87	132	241	2.6	7.2	2.9	84	372
C1A 280MT	90	2970	0.587	93.9	0.88	158	289	2.7	7.5	3	87	407
C1A 315ST	110	2975	0.751	93.5	0.89	191	353	2.6	7.5	2.8	87	496
C1A 315M	132	2980	1.27	93.5	0.89	229	423	2.5	7.4	2.7	90	620
C1A 315M	160	2980	1.52	93.5	0.89	278	513	2.5	7.4	2.7	90	668
C1A 315M	200	2980	1.83	94	0.9	342	641	2.5	7.4	2.7	90	760
C1A 355LT	250	2980	2.29	94	0.9	427	801	2.2	7.5	2.4	90	895

I valori di rendimento sono calcolati in accordo con IEC 60034-2-1.

Efficiency values are given according to IEC 60034-2-1.

Dati tecnici

Technical data

Classe di efficienza IE1 (IEC 60034-30; 2008)
Isolamento classe F - Servizio S1 - 400 V - 50 Hz
4 poli - 1.500 giri/min

IE1 Efficiency class (IEC 60034-30; 2008)
Insulation class F - S1 Duty - 400 V - 50 Hz
4 poles - 1.500 rpm

Tipo Type	Potenza Power	Velocità Speed	J	Rend. Eff.	Fattore di potenza Power factor	Corrente Current In (400 V)	Coppia nom. Nominal torque	Coppia di spunto Starting torque	Corrente di spunto Starting current	Coppia massima Max torque	Rumor. Noise	Forma B3 Mount B3 Peso Weight
	kW	giri/min rpm	kgm ²	%	cosφ	A	Nm	Ca/Cn Tst/Tn	Ia/In Ist/In	Cmax/Cn Tmax/Tn	dB (A)	kg
Serie CA (carcassa in alluminio) - CA Series (aluminium frame)												
CA 63-a	0.13	1340	0.0002	60	0.6	0.5	0.93	2.3	3	2.3	49	3.8
CA 63-b	0.18	1340	0.0003	61	0.6	0.7	1.28	2.3	3	2.3	49	4.1
CA 71-a	0.25	1350	0.0004	68	0.65	0.8	1.77	2	3.5	2	51	5.7
CA 71-b	0.37	1350	0.0005	69	0.67	1.2	2.62	2	3.5	2	51	7
CA 80-a	0.55	1360	0.0012	72	0.7	1.6	3.86	2.3	4.3	2.3	54	8.6
C1A 80-b	0.75	1360	0.0017	73	0.73	2.0	5.27	2.3	4.3	2.3	54	10
C1A 90S	1.1	1380	0.0022	76.2	0.78	2.7	7.61	2.3	4.5	2.5	56	11.9
C1A 90L	1.5	1380	0.0028	78.5	0.77	3.6	10.38	2.3	4.5	2.5	56	14.2
C1A 100L-a	2.2	1410	0.005	81	0.79	5.0	14.90	2	4.5	2.2	60	18.7
C1A 100L-b	3	1410	0.006	82.6	0.8	6.6	20.32	2	4.5	2.2	60	21.2
C1A 112MT	4	1420	0.009	84.2	0.81	8.5	26.9	2.4	5	2.5	60	25.7
C1A 132S	5.5	1430	0.021	85.7	0.8	11.6	36.7	2.1	6	2.5	63	43
C1A 132M-a	7.5	1430	0.028	87	0.81	15.4	50.1	2.1	6	2.5	63	50.3
C1A 132M-b	9	1430	0.034	87	0.81	18.5	60.1	2.1	6	2.5	63	55.8
C1A 160MT	11	1465	0.039	88.4	0.83	21.7	71.7	2.6	5.9	2.6	63	69.5
C1A 160L	15	1465	0.08	89.4	0.82	29.6	97.8	2.6	6	2.6	67	89
C1A 180MT	18.5	1470	0.098	90	0.83	35.8	120	2.5	6.5	2.8	67	110
C1A 180LT	22	1470	0.12	90.5	0.83	42.3	143	2.5	6.5	2.8	67	119
C1A 200LT	30	1470	0.16	91.4	0.85	56	195	2.4	6.5	2.8	70	155
C1A 225ST	37	1480	0.31	92	0.84	69	239	2.6	7.1	2.9	70	202
C1A 225MT-a	45	1480	0.39	92.5	0.84	84	290	2.6	7.1	2.9	70	235
C1A 250MT-b	55	1480	0.51	93	0.85	101	355	2.5	7.3	2.6	70	286
C1A 280ST	75	1485	1.15	93.6	0.86	135	482	2.5	7.3	2.7	73	387
C1A 280MT	90	1485	1.31	93.9	0.86	161	579	2.6	6.7	2.7	73	415
C1A 315ST	110	1485	1.55	94	0.88	192	707	2.6	6.7	2.7	75	496
C1A 315M-a	132	1485	2.6	94	0.88	231	849	2.2	6.2	2.7	77	630
C1A 315M-b	160	1485	3.5	94	0.88	280	1029	2.5	6.6	2.7	77	740
C1A 315M-c	200	1485	4.16	94.2	0.89	345	1286	2.6	6.8	2.8	77	882
C1A 355LT	250	1487	5	94.4	0.89	430	1605	2.7	7	2.3	77	1045

I valori di rendimento sono calcolati in accordo con IEC 60034-2-1.

Efficiency values are given according to IEC 60034-2-1.

Dati tecnici

Classe di efficienza IE1 (IEC 60034-30; 2008)
Isolamento classe F - Servizio S1 - 400 V - 50 Hz
6 poli - 1.000 giri/min

Technical data

IE1 Efficiency class (IEC 60034-30; 2008)
Insulation class F - S1 Duty - 400 V - 50 Hz
6 poles - 1.000 rpm

Tipo Type	Potenza Power	Velocità Speed	J	Rend. Eff.	Fattore di potenza Power factor	Corrente Current In (400 V)	Coppia nom. Nominal torque	Coppia di spunto Starting torque	Corrente di spunto Starting current	Coppia massima Max torque	Rumor. Noise	Forma B3 Mount B3 Peso Weight
	kW	giri/min rpm	kgm ²	%	cosφ	A	Nm	Ca/Cn Tst/Tn	Ia/In Ist/In	Cmax/Cn Tmax/Tn	dB (A)	kg
Serie CA (carcassa in alluminio) - CA Series (aluminium frame)												
CA 63-a	0.09	880	0.0003	43	0.6	0.5	0.98	1.7	2.2	1.9	48	5
CA 63-b	0.11	890	0.0004	45	0.6	0.6	1.18	1.7	2.8	1.9	48	5.2
CA 71-a	0.18	890	0.0011	54	0.61	0.8	1.93	1.7	2.8	1.9	49	5.8
CA 71-b	0.22	890	0.0013	55	0.61	0.9	2.36	1.8	2.8	2	49	6.5
CA 80-a	0.37	900	0.0016	66	0.71	1.1	3.93	1.8	3	2	51	7.4
CA 80-b	0.55	900	0.0026	69	0.71	1.6	5.84	2.05	3.5	2.2	51	9.8
C1A 90S	0.75	910	0.0035	72	0.72	2.1	7.87	1.9	3.8	2.1	54	10.8
C1A 90L	1.1	910	0.0051	73	0.72	3.0	11.54	2	4	2	54	13.5
C1A 100L	1.5	920	0.0087	75	0.73	4.0	15.6	2.1	4.7	2.3	57	19.6
C1A 112MT	2.2	940	0.014	78	0.75	5.4	22.3	2.2	5.5	2.5	57	25
C1A 132S	3	950	0.023	80	0.78	6.9	30.2	2	5.6	2.3	60	39
C1A 132M-a	4	950	0.031	82	0.78	9.0	40.2	2.3	5.8	2.6	60	45.5
C1A 132M-b	5.5	950	0.041	83	0.78	12.3	55.3	2.3	6	2.6	60	52.5
C1A 160MT	7.5	960	0.054	85	0.8	15.9	74.6	2.1	6	2.6	60	69
C1A 160L	11	960	0.109	86	0.81	22.8	109.4	2.3	6.4	2.9	63	88
C1A 180LT	15	970	0.141	87	0.82	30.4	147.7	2.4	7.2	3	63	114
C1A 200LT-a	18.5	975	0.271	88	0.83	36.6	181.2	2.3	6.8	2.8	68	145
C1A 200LT-b	22	975	0.32	88	0.83	43.5	215	2.3	6.8	2.8	68	155
C1A 225MT	30	980	0.541	90	0.84	57.3	292	2.4	6.1	2.6	72	234
C1A 250MT	37	980	0.752	91	0.84	69.9	361	2.4	6.8	2.7	73	295
C1A 280ST	45	985	1.37	92	0.82	87	436	2.3	6.5	2.4	75	381
C1A 280MT	55	985	1.68	92	0.82	105	533	2.3	6.5	2.4	75	421
C1A 315ST	75	985	2.37	92	0.83	141	727	2.1	6	2.3	75	526
C1A 315M-a	90	988	2.7	93	0.83	169	870	2.3	5.8	2.6	84	642
C1A 315M-b	110	986	2.7	93	0.84	204	1065	2.3	5.8	2.6	84	672
C1A 315M-c	132	986	3.15	93.3	0.84	243	1278	2.3	5.9	2.6	84	730
C1A 315M-d	160	987	4.7	94	0.84	293	1548	2.4	6	2.6	84	910
C1A 355LT	200	987	5.7	94	0.84	366	1935	2.4	6	2.6	84	1144

I valori di rendimento sono calcolati in accordo con IEC 60034-2-1.

Efficiency values are given according to IEC 60034-2-1.

Dati tecnici

Technical data

Isolamento classe F - Servizio S1 - 400 V - 50 Hz
8 poli - 750 giri/min

Insulation class F - S1 Duty - 400 V - 50 Hz
8 poles - 750 rpm

Tipo Type	Potenza Power	Velocità Speed	J	Rend. Eff.	Fattore di potenza Power factor	Corrente Current In (400 V)	Coppia nom. Nominal torque	Coppia di spunto Starting torque	Corrente di spunto Starting current	Coppia massima Max torque	Rumor. Noise	Forma B3 Mount B3 Peso Weight
	kW	giri/min rpm	kgm ²	%	cosφ	A	Nm	Ca/Cn Tst/Tn	Ia/In Ist/In	Cmax/Cn Tmax/Tn	dB (A)	kg
Serie CA (carcassa in alluminio) - CA Series (aluminium frame)												
CA 63	0.05	640	0.00029	40	0.53	0.34	0.75	1.5	2	1.6	48	5
CA 63	0.07	640	0.00039	44	0.54	0.43	1.04	1.5	2	1.6	48	5
CA 71	0.11	650	0.0011	44	0.56	0.65	1.6	1.5	2	1.6	49	6
CA 71	0.15	650	0.0013	46	0.57	0.83	2.2	1.6	2.1	1.6	49	6.5
CA 80	0.18	670	0.0016	52	0.6	0.83	2.6	1.8	3	2	51	7.3
CA 80	0.25	670	0.0026	61	0.6	1	3.6	1.8	3	2	51	9.7
CA 90S	0.37	680	0.003	64	0.63	1.3	5.2	1.8	3.2	2	53	10.6
CA 90L	0.55	690	0.0045	67	0.63	1.9	7.6	1.8	3.4	2	53	13.3
CA 100L	0.75	690	0.0087	68	0.64	2.5	10.4	2	3.4	2.1	55	19.3
CA 100L	1.1	690	0.0109	70	0.64	3.5	15.2	2	3.4	2.1	55	21.5
CA 112MT	1.5	700	0.0141	73	0.65	4.6	20.5	1.9	3.5	2.4	55	25
CA 132S	2.2	705	0.0307	78	0.71	5.7	29.8	1.9	4.6	2.2	58	45
CA 132M	3	710	0.0409	79	0.72	7.6	40.4	1.9	5	2.3	58	52
CA 160MT	4	710	0.0537	80	0.73	9.9	53.8	2	5	2.1	58	68.5
CA 160M	5.5	715	0.0772	82	0.73	13	73	2	5.2	2.1	61	70
CA 160L	7.5	720	0.109	84	0.74	17	100	2.1	5.4	2.2	61	87.5
CA 180LT	11	730	0.154	86	0.76	24	144	2.1	5.1	2	61	117
CA 200LT	15	730	0.345	87	0.76	33	196	2.1	5.4	2.3	66	155
CA 225ST	18.5	730	0.505	88	0.79	38	242	2.3	5.3	2.3	70	207
CA 225MT	22	730	0.577	89	0.79	45	288	2.3	5.3	2.4	70	243
CA 250MT	30	735	0.902	90	0.8	60	390	2.4	5.5	2.6	71	317
CA 280ST	37	735	1.75	90.5	0.8	74	481	2.1	5	2.3	72	420
CA 280MT	45	735	2.12	91	0.8	89	585	2.1	5.1	2.3	72	460
CA 315ST	55	740	2.43	92	0.8	108	710	2.3	5.5	2.2	81	525
CA 315M	75	740	3.1	93	0.8	146	968	1.6	5.2	2.2	81	671
CA 315M	90	740	3.52	93.5	0.8	174	1162	1.6	5.2	2.3	81	769
CA 315M	110	740	4.4	93.8	0.8	212	1420	1.6	5.3	2.3	81	890
CA 315M	132	740	5.1	94	0.8	254	1704	1.6	5.3	2.4	81	1035
Serie CS (carcassa in acciaio) - CS Series (steel frame)												
CS 355L-b	200	742	10.5	94.5	0.81	378	2575	1.5	5.6	2.4	79	1590
CS 355L-c	250	745	12.6	94.5	0.82	466	3205	1.5	5.6	2.4	79	1760
CS 355Lx-a	315	745	28.9	95	0.80	600	4039	1.4	6	2.4	79	2520
CS 355Lx-b	355	745	34.0	95	0.81	667	4550	1.5	6	2.5	79	2840
CS 400Lx-b	400	745	41.8	95.4	0.84	721	5127	1.4	6	2.4	81	3200
CS 400Lx-c	450	745	49.9	95.5	0.84	811	5768	1.5	6	2.4	81	3540
CS 450Lx-a	500	745	69.5	95.6	0.84	900	6409	1.5	6	2.5	83	4060
CS 450Lx-b	560	745	81.7	95.8	0.84	1006	7178	1.5	6	2.5	83	4440
CS 500Lx-a	630	745	101.1	96	0.86	1103	8075	1	6	2.4	83	5010
CS 500Lx-b	710	745	113.8	96	0.86	1243	9100	1	6	2.4	83	5440
CS 500Lx-c	800	745	129.6	96.1	0.86	1399	10254	1	6	2.4	83	5980

La classificazione dell'efficienza riguarda solo i motori a 2, 4, e 6 poli.

Efficiency classification concerns only 2, 4 and 6 pole motors.

Dati tecnici

Classe di efficienza IE2 (IEC 60034-30; 2008)

Alta efficienza

Isolamento classe F - Sovratemperatura classe B

Servizio S1 - 400 V - 50 Hz

2 poli - 3.000 giri/min

Technical data

IE2 Efficiency class (IEC 60034-30; 2008)

High Efficiency

Insulation class F - Temperature rise class B

S1 Duty - 400 V - 50 Hz

2 poles - 3.000 rpm

Tipo Type	Potenza Power	Velocità Speed	J	Rendimento Efficiency			Fattore di potenza Power factor cosφ			Corrente Current In (400 V)	Coppia nom. Nom. torque	Coppia di spunto Starting torque	Corrente di spunto Starting current	Coppia massima Max torque	Rumor. Noise	Forma B3 Mount. B3 Peso Weight
	kW	giri/min rpm		kgm ²	100%	75%	50%	100%	75%	50%	A	Nm	Ca/Cn Tst/Tn	Ia/In Ist/In	Cmax/Cn Tmax/Tn	dB (A)
Serie C2A (carcassa in alluminio) - C2A Series (aluminium frame)																
C2A 80-a	0.75	2870	0.0015	77.4	79	76.6	0.8	0.71	0.54	1.8	2.49	2.3	4.5	2.4	61	9.6
C2A 80-b	1.1	2975	0.0020	79.6	80.2	77.2	0.8	0.72	0.57	2.5	3.53	2.6	5.5	2.7	61	11.2
C2A 90S	1.5	2830	0.0016	81.3	80.6	79.9	0.82	0.78	0.67	3.3	5.06	2.6	5.5	2.6	65	13.9
C2A 90L	2.2	2880	0.0023	83.2	83.6	83.1	0.82	0.78	0.67	4.7	7.29	2.6	5.8	2.6	65	15.9
C2A 100L	3	2880	0.0042	84.6	84.7	83.2	0.84	0.78	0.67	6.1	9.95	2.4	6.2	2.5	69	23.8
C2A 112MT-a	4	2910	0.0056	85.8	86.3	86	0.84	0.78	0.67	8.0	13.13	2.3	6.8	2.6	69	28
C2A 132S-a	5.5	2880	0.0112	87	86.7	84.7	0.9	0.87	0.8	10.2	18.24	2.2	6.8	2.5	69	43.3
C2A 132S-b	7.5	2920	0.0146	87	87.6	87.2	0.9	0.88	0.82	13.8	24.5	2.3	7	2.6	71	49.5
C2A 160M-a	11	2935	0.031	89.4	89.5	87.7	0.88	0.85	0.77	20.2	36	2	6.2	2.8	71	76
C2A 160M-b	15	2936	0.041	90.3	90.5	89.4	0.89	0.85	0.78	27.0	49	2.3	6.7	2.8	72	90
C2A 160L	18.5	2938	0.048	90.9	91	90.3	0.89	0.85	0.78	33.0	60	2.4	7.2	2.9	72	110
C2A 180MT	22	2938	0.055	91.3	91.5	90	0.89	0.86	0.79	39.1	72	2.6	7.2	2.9	72	116
C2A 200LT-a	30	2945	0.105	92	92	91	0.91	0.89	0.85	51.8	97	2	7	2.8	81	162
C2A 200LT-b	37	2947	0.126	92.5	92.6	91.3	0.91	0.89	0.85	63.5	120	2.2	7	3	81	184
C2A 225MT (*)	45	2960	0.18	92.9	92.9	91.4	0.9	0.88	0.8	77.8	145	2.6	7.5	3	81	222
C2A 250MT	55	2965	0.29	93.2	92.1	90.3	0.9	0.88	0.81	94.8	177	2.6	7.5	3	81	280
C2A 280ST	75	2965	0.553	93.8	93.3	91.1	0.9	0.88	0.84	128.4	242	2.4	7.2	2.7	84	408
C2A 280MT	90	2968	0.664	94.1	93.7	92	0.9	0.88	0.88	153.6	290	2.4	7.2	2.8	84	495
C2A 315ST	110	2970	0.751	94.3	94.8	93	0.9	0.88	0.89	187.3	354	2.6	7.5	2.8	84	553
C2A 315M-a	132	2875	1.53	94.6	94.7	93.2	0.9	0.88	0.84	224	438	1.9	7	2.3	87	692
C2A 315M-b	160	2875	1.83	94.8	94.7	94.3	0.9	0.89	0.86	271	531	1.9	7	2.3	87	764
C2A 315M-c	200	2875	1.83	95	94.9	93.5	0.9	0.89	0.86	338	664	2	7	2.3	87	860
Serie C2S (carcassa in acciaio) - C2S Series (steel frame)																
C2S 355L	250	2983	3.5	95.1	94	93.5	0.91	0.9	0.87	417	800	2	7	2.3	88	1200
C2S 355L-a	280	2980	4.2	95.1	94.1	93.5	0.91	0.9	0.87	468	898	2	7	2.3	88	1280
C2S 355L-b	315	2980	4.5	95.1	94.1	93.3	0.91	0.9	0.87	526	1010	2.3	7.5	2.5	88	1600
C2S 355L-a	355	2980	3.2	95.1	94.1	93.3	0.9	0.9	0.87	599	1202	2.2	7.5	2.4	89	1870
C2S 355Lx-b	400	2985	7.7	95.2	94.2	93.4	0.9	0.9	0.87	675	1280	2.2	7.5	2.4	89	2000
C2S 355Lx-c	450	2985	8.4	95.2	94.2	93.4	0.9	0.9	0.87	759	1440	2.2	7.5	2.4	89	2150

I valori di rendimento sono calcolati in accordo con IEC 60034-2-1.

Efficiency values are given according to IEC 60034-2-1.

Dati tecnici

Classe di efficienza IE2 (IEC 60034-30; 2008)

Alta efficienza

Isolamento classe F - Sovratemperatura classe B

Servizio S1 - 400 V - 50 Hz

4 poli - 1.500 giri/min

Technical data

IE2 Efficiency class (IEC 60034-30; 2008)

High Efficiency

Insulation class F - Temperature rise class B

S1 Duty - 400 V - 50 Hz

4 poles - 1.500 rpm

Tipo Type	Potenza Power	Velocità Speed	J	Rendimento Efficiency			Fattore di potenza Power factor cosφ			Corrente Current In (400 V)	Coppia nom. Nom. torque	Coppia di spunto Starting torque	Corrente di spunto Starting current	Coppia massima Max torque	Rumor. Noise	Forma B3 Mount B3 Peso Weight
	kW	giri/min rpm	kgm²	100%	75%	50%	100%	75%	50%	A	Nm	Ca/Cn Tst/Tn	Ia/In Ist/In	Cmax/Cn Tmax/Tn	dB (A)	kg
Serie C2A (carcassa in alluminio) - C2A Series (aluminium frame)																
C2A 80-b	0.75	1360	0.0019	79.6	79	78	0.73	0.69	0.58	1.9	5.27	2.3	5	2.3	50	11
C2A 90S	1.1	1395	0.0028	81.4	81	79	0.81	0.74	0.61	2.4	7.53	2.3	4.7	2.5	50	14.2
C2A 90L	1.5	1400	0.0373	82.8	82	80	0.81	0.74	0.61	3.2	10.23	2.6	5	2.6	52	17.8
C2A 100L-a	2.2	1425	0.006	84.3	84.6	84.4	0.8	0.74	0.62	4.7	14.74	2	5	2.2	52	21.2
C2A 100L-b	3	1425	0.008	85.5	85.8	84.9	0.8	0.74	0.62	6.3	20.10	2	5	2.2	56	26.2
C2A 112M	4	1420	0.014	86.6	87.5	87.5	0.8	0.73	0.62	8.3	26.90	2.4	5	2.5	56	35
C2A 132S	5.5	1452	0.023	87.7	87.9	87	0.8	0.72	0.61	11.3	36.2	1.8	5.5	2.5	56	48
C2A 132M	7.5	1456	0.034	88.7	88.9	88	0.81	0.73	0.62	15.1	49.2	2	5.8	2.6	59	58
C2A 132 Mb	9.2	1457	0.037	89.3	89.3	88.4	0.81	0.73	0.6	18.38	60.3	2	5.9	2.7	59	65.2
C2A 160M	11	1463	0.076	89.8	90	89.8	0.83	0.76	0.63	21.3	71.8	2.4	5.8	2.5	59	85.5
C2A 160L	15	1463	0.093	90.6	91	90.6	0.83	0.76	0.63	28.8	97.9	2.6	6	2.6	63	104
C2A 180MT	18.5	1465	0.11	91.2	91.4	91.1	0.83	0.77	0.63	35	120.6	2.5	6	2.5	63	125
C2A 180L	22	1465	0.153	91.6	92	91.6	0.87	0.83	0.74	40	143.4	2.2	6	2.6	63	155
C2A 200LT	30	1465	0.195	92.3	92.6	92.2	0.87	0.83	0.74	54	195.5	2.2	6.2	2.8	66	186
C2A 225ST	37	1470	0.352	92.7	92.7	92	0.87	0.83	0.74	66	240.3	2.6	7.1	2.9	66	230
C2A 225M	45	1474	0.429	93.1	93.2	93	0.88	0.82	0.74	79	292	2.6	7.5	2.9	66	263
C2A 250MT	55	1475	0.55	93.5	93.4	93	0.88	0.84	0.75	97	356	2.8	7.6	3	66	315
C2A 280ST	75	1480	1.25	94	93.8	93.7	0.88	0.85	0.76	131	484	2.6	7	2.6	70	407
C2A 280MT	90	1480	1.48	94.2	94	93.8	0.88	0.85	0.76	157	581	2.6	7	2.6	70	474
C2A 315M-a	110	1488	2.6	94.5	94.3	93.3	0.86	0.83	0.74	196	706	2.6	7	2.6	80	660
C2A 315M-b	132	1488	3.2	94.7	94.7	94	0.86	0.83	0.74	234	847	2.6	7.2	2.6	80	733
C2A 315M-c	160	1488	3.9	94.9	94.8	94	0.88	0.85	0.78	277	1027	2.7	7.2	2.7	80	848
C2A 315M-d	200	1485	4.7	95.1	95	94.2	0.88	0.85	0.78	345	1286	2.7	7.2	2.8	80	1026
Serie C2S - CS (carcassa in acciaio) - C2S - CS Series (steel frame)																
C2S 355L-a	250	1492	5.5	95.1	94.4	92.4	0.87	0.85	0.75	437	1600	1.4	6.4	2.4	84	1360
C2S 355L-b	280	1492	5.8	95.1	94.6	93	0.88	0.84	0.77	483	1792	1.4	6.4	2.4	84	1490
C2S 355L-c	315	1492	6.6	95.3	94.7	93	0.88	0.85	0.77	543	2016	1.4	6.5	2.4	84	1680
C2S 355Lx-a ^(*)	355	1492	10.0	95.3	94.8	93.3	0.89	0.87	0.81	605	2272	1.3	6.8	2.8	84	1850
CS 355Lx-b ^(*)	400	1492	11.8	95.5	94.9	93.7	0.89	0.88	0.81	680	2560	1.4	7	2.8	84	2060
CS 355Lx-c ^(*)	450	1492	13.6	95.7	95.2	94	0.90	0.87	0.81	755	2880	1.4	7	2.8	84	2260
CS 355Lx-d ^(*)	500	1492	15.9	95.8	95.2	94	0.90	0.87	0.81	838	3200	1.4	7	2.8	84	2520
CS 400Lx-a ^(*)	560	1495	27.0	96	95.4	94.2	0.87	0.83	0.76	969	3577	1.8	7.5	2.5	85	3150
CS 400Lx-b ^(*)	630	1490	31.6	96	95.4	94.2	0.87	0.83	0.76	1090	4037	2	7.5	2.5	85	3520
CS 450Lx-a	710	1495	36.0	96.5	96	95.2	0.89	0.87	0.84	1195	4535	1.5	7	2	85	4100
CS 450Lx-b	800	1495	41.8	96.7	96.2	95.2	0.89	0.87	0.84	1343	5110	1.8	7.5	2.4	85	4420
CS 500Lx-a ^(*)	900	1496	70.6	96.7	96.2	95.2	0.88	0.86	0.82	1528	5745	1.5	7	2.3	85	4950
CS 500Lx-c ^(*)	1000	1495	78.2	96.9	96.6	95.6	0.89	0.87	0.83	1676	6387	1.6	7	2.3	85	5300

^(*) Sovratemperatura classe F

I valori di rendimento sono calcolati in accordo con IEC 60034-2-1.

^(*) Temperature rise class F

Efficiency values are given according to IEC 60034-2-1.

Dati tecnici

Classe di efficienza IE2 (IEC 60034-30; 2008)

Alta efficienza

Isolamento classe F - Sovratemperatura classe B

Servizio S1 - 400 V - 50 Hz

6 poli - 1.000 giri/min

Technical data

IE2 Efficiency class (IEC 60034-30; 2008)

High Efficiency

Insulation class F - Temperature rise class B

S1 Duty - 400 V - 50 Hz

6 poles - 1.000 rpm

Tipo Type	Potenza Power	Velocità Speed	J	Rendimento Efficiency			Fattore di potenza Power factor cosφ			Corrente Current In (400 V)	Coppia nom. Nom. torque	Coppia di spunto Starting torque	Corrente di spunto Starting current	Coppia massima Max torque	Rumor. Noise	Forma B3 Mount B3 Peso Weight
	kW	giri/min rpm		kgm ²	100%	75%	50%	100%	75%	50%	A	Nm	Ca/Cn Tst/Tn	Ia/In Ist/In	Cmax/Cn Tmax/Tn	dB (A)
Serie C2A (carcassa in alluminio) - C2A Series (aluminium frame)																
C2A 90S	0.75	925	0.005	75.9	74	68	0.66	0.55	0.4	2.16	7.742	2.5	5	2.9	54	13.5
C2A 90L	1.1	925	0.006	78.1	76	72	0.7	0.59	0.43	2.9	11.36	2.8	5.2	3	54	16.5
C2A 100L	1.5	950	0.013	79.8	77	72	0.71	0.58	0.44	3.8	15.08	2.1	4.7	2.5	57	25
C2A 112M	2.2	950	0.018	81.8	82	78	0.71	0.59	0.45	5.5	22.11	2.2	5.8	2.6	57	30
C2A 132S	3	955	0.029	83.3	83.3	81.2	0.72	0.61	0.47	7.2	30	2.2	5.6	2.8	60	45.5
C2A 132M-a	4	955	0.039	84.6	84.6	82.6	0.72	0.62	0.48	9.5	40	2.3	6	2.9	60	52.5
C2A 132M-b	5.5	955	0.051	86	86	84.3	0.73	0.63	0.49	12.7	54.99	2.4	6	3	60	69
C2A 160M	7.5	960	0.104	87.2	87.2	86	0.78	0.68	0.54	15.9	74.6	2.6	7	3	63	88
C2A 160L	11	965	0.123	88.7	88.4	87.2	0.78	0.69	0.54	23.0	108.8	2.6	7.4	3	63	114
C2A 180LT	15	970	0.16	89.7	89.2	87.8	0.78	0.69	0.54	31	147.7	2.7	7.5	3	63	125
C2A 200LT-a	18.5	980	0.38	90.4	90.6	89	0.86	0.81	0.7	34	180.3	2.5	6.8	2.8	68	134
C2A 200LT-b	22	980	0.45	90.9	91	89.9	0.86	0.81	0.7	41	214.4	2.7	7	2.9	68	155
C2A 225M	30	980	0.72	91.7	91.9	91.1	0.82	0.76	0.62	58	292.3	2.6	7	2.9	72	295
C2A 250MT	37	980	0.864	92.2	92.3	91.7	0.82	0.76	0.62	71	360.5	2.6	7	2.9	73	332
C2A 280ST	45	985	1.72	92.7	92.4	91.7	0.83	0.78	0.67	85	436.2	2.3	6	2.3	75	421
C2A 280MT	55	985	2.17	93.1	92.7	91.7	0.83	0.78	0.68	103	533.2	2.4	6	2.3	75	490
C2A 315ST	75	985	2.68	93.7	93.2	92.3	0.83	0.78	0.68	139	727.1	2.4	6	2.3	75	565
C2A 315M-a	90	988	3.14	94	93.5	92.4	0.83	0.8	0.68	167	870	2.4	6.5	2.7	82	672
C2A 315M-b	110	988	3.73	94.3	93.9	93.1	0.84	0.8	0.7	201	1063	2.4	6.5	2.7	82	730
C2A 315M-c	132	988	4.7	94.6	94.2	93.2	0.84	0.8	0.7	240	1276	2.7	7	2.9	82	910
C2A 315M-d	160	988	5.7	94.8	94.4	93.5	0.84	0.81	0.7	290	1546	2.7	7	2.9	82	1100
Serie C2S - CS (carcassa in acciaio) - C2S - CS Series (steel frame)																
C2S 355L	200	990	6.4	95	94.9	94.4	0.86	0.83	0.74	354	1929	1.9	5.6	2.2	82	1370
C2S 355L-a (*)	250	990	7.9	95.1	95.2	94.6	0.86	0.83	0.75	442	2411	2.2	5.6	2.2	82	1572
C2S 355L-b (*)	280	990	8.7	95.1	95.3	94.6	0.86	0.83	0.75	495	2701	2.2	5.8	2.3	82	1660
C2S 355L-c (*)	315	990	9.8	95	95.2	94.6	0.86	0.83	0.75	557	3038	1.2	5.6	2.3	82	1800
C2S 355Lx-a (*)	355	990	19.8	95.5	95.5	95.4	0.89	0.87	0.79	604	3424	1.4	6	2.5	82	2060
CS 355Lx-b (*)	400	990	22.3	95.5	95.6	95.5	0.89	0.87	0.79	680	3858	1.4	6	2.6	82	2254
CS 400Lx-a (*)	450	994	31.1	95.6	95.5	94.8	0.89	0.87	0.79	764	4323	1.2	6	2.6	84	2960
CS 400Lx-b	500	994	35.0	95.7	95.7	94.9	0.89	0.87	0.79	848	4803	1.2	6	2.6	84	3290
CS 400Lx-c	560	995	39.8	95.7	95.7	94.9	0.89	0.87	0.79	950	5374	1.3	6.2	2.8	84	3530
CS 450Lx-a	630	995	60.0	96	95.9	95	0.88	0.85	0.78	1078	6046	1.3	6.8	3	85	4200
CS 450Lx-b	710	995	68.0	96	95.9	95	0.88	0.85	0.78	1215	6814	1.3	6.9	3.2	85	4560
CS 500Lx-a	800	995	74.0	96.3	96.3	95.8	0.89	0.87	0.80	1349	7678	0.8	5.9	2.5	85	4890
CS 500Lx-b	900	995	86.0	96.4	96.4	95.8	0.89	0.87	0.80	1516	8637	0.9	6	2.6	85	5500

(*) Sovratemperatura classe F

I valori di rendimento sono calcolati in accordo con IEC 60034-2-1.

(*) Temperature rise class F

Efficiency values are given according to IEC 60034-2-1.

Dati tecnici

Classe di efficienza IE3 (IEC 60034-30; 2008)

Efficienza Premium

Isolamento classe F - Sovratemperatura classe B

Servizio S1 - 400 V - 50 Hz

2 poli - 3.000 giri/min

Technical data

IE3 Efficiency class (IEC 60034-30; 2008)

Premium Efficiency

Insulation class F - Temperature rise class B

S1 Duty - 400 V - 50 Hz

2 poles - 3.000 rpm

Tipo Type	Potenza Power	Velocità Speed	J	Rendimento Efficiency			Fattore di potenza Power factor cosφ			Corrente Current In (400 V)	Coppia nom. Nom. torque	Coppia di spunto Starting torque	Corrente di spunto Starting current	Coppia massima Max torque	Rumor. Noise	Forma B3 Mount B3 Peso Weight
	kW	giri/min rpm		kgm ²	100%	75%	50%	100%	75%	50%	A	Nm	Ca/Cn Tst/Tn	Ia/In Ist/In	Cmax/Cn Tmax/Tn	dB (A)
Serie C3A (carcassa in alluminio) - C3A Series (aluminium frame)																
C3A 80-a	0.75	2860	0.00145	80.7	80	0.76	0.87	0.85	0.78	1.5	2.504	2.6	6	2.8	60	11.2
C3A 80-b	1.1	2875	0.0020	82.7	82.5	0.8	0.88	0.72	0.79	2.2	3.654	2.7	6	2.8	60	13.2
C3A 90S	1.5	2937	0.0016	84.2	83.4	81	0.76	0.64	0.64	3.4	4.877	3	6.2	3.2	64	13.9
C3A 90L	2.2	2840	0.0022	85.9	85.4	84.3	0.86	0.81	0.69	4.3	7.397	3	6.7	3	64	15.9
C3A 100L	3	2900	0.0054	87.1	87.1	86.8	0.86	0.81	0.7	5.8	9.88	2.4	6.7	3	68	28
C3A 112M	4	2895	0.0083	88.1	88	86.8	0.86	0.81	0.7	7.6	13.19	2.3	6.7	3	68	33
C3A 132S-b	5.5	2910	0.0143	89.2	89.3	98.0	0.89	0.87	0.81	10.0	18.05	2.3	7	3	70	49.5
C3A 132S-b	7.5	2930	0.016	90.1	91	89.4	0.89	0.87	0.81	13.5	24.4	2.2	7	3	70	53
C3A 160M-a	11	2947	0.041	91.2	91	89.4	0.9	0.88	0.81	19.4	36	2.8	8.3	3.4	70	90
C3A 160M-b	15	2947	0.048	91.9	91.8	90.0	0.89	0.86	0.78	26.5	49	2.8	8	3.4	70	110
C3A 160L	18.5	2948	0.055	92.4	92.0	90.6	0.88	0.85	0.74	32.9	60	2.8	7.5	3	70	116
C3A 180L-T	22	2960	0.060	92.7	92	91.1	0.89	0.86	0.78	38.5	71	2.6	7.7	3.4	71	160
C3A 200LT	30	2960	0.126	93.3	93.2	92.1	0.9	0.87	0.80	51.6	97	2.6	7.8	3.5	78	184
C3A 200L	37	2965	0.182	93.7	93.3	92	0.9	0.87	0.80	63.4	119	2.6	7.8	3.3	78	220
C3A 225MT	45	2965	0.182	94.0	93.4	92.4	0.9	0.88	0.81	76.0	145	2.6	7.8	3.2	78	220
C3A 250MT	55	2970	0.349	94.3	93.7	92.5	0.9	0.89	0.84	92.6	177	2.7	7.5	3	78	330
C3A 280ST	75	2970	0.707	94.7	94.6	93.8	0.91	0.90	0.87	126	241	2.3	7	2.7	82	495
C3A 280MT	90	2970	0.840	95	94.7	93.7	0.91	0.90	0.87	150	289	2.6	7.5	3	82	550
C3A 315S	110	2973	1.531	95.2	94.8	93.7	0.91	0.9	0.87	183	353	1.9	6.8	2.4	84	750
C3A 315Ma	132	2973	1.837	95.4	95.1	94.2	0.91	0.9	0.89	220	424	2	7	2.4	84	810
C3A 315Md	160	2973	2.143	95.6	95.5	94.8	0.91	0.91	0.9	266	514	2.1	6.8	2.5	84	916
C3A 315Me	200	2975	2.449	95.8	95.7	95.4	0.91	0.91	0.89	332	642	2.2	7	2.5	84	1005
Serie C3S (carcassa in acciaio) - C3S Series (steel frame)																
C3S 355L-a	250	2982	4.35	95.8	95.5	94.6	0.91	0.91	0.88	414	801	2.2	7	2.3	85	1560
C3S 355L-b	280	2983	4.69	95.8	95.6	94.8	0.91	0.91	0.88	464	898	2.4	7.4	2.4	85	1720
C3S 355Lx-a	315	2985	6.23	95.8	95.7	94.8	0.91	0.91	0.89	522	1010	1.5	6.5	2.3	85	1800
C3S 355Lx-b	355	2985	6.82	95.8	95.7	95.1	0.91	0.9	0.89	588	1202	1.6	6.7	2.4	85	1900

I valori di rendimento sono calcolati in accordo con IEC 60034-2-1.

Efficiency values are given according to IEC 60034-2-1.

Dati tecnici

Classe di efficienza IE3 (IEC 60034-30; 2008)

Efficienza Premium

Isolamento classe F - Sovratemperatura classe B

Servizio S1 - 400 V - 50 Hz

4 poli - 1.500 giri/min

Technical data

IE3 Efficiency class (IEC 60034-30; 2008)

Premium Efficiency

Insulation class F - Temperature rise class B

S1 Duty - 400 V - 50 Hz

4 poles - 1.500 rpm

Tipo Type	Potenza Power	Velocità Speed	J	Rendimento Efficiency			Fattore di potenza Power factor cosφ			Corrente Current In (400 V)	Coppia nom. Nom. torque	Coppia di spunto Starting torque	Corrente di spunto Starting current	Coppia massima Max torque	Rumor. Noise	Forma B3 Mount B3 Peso Weight
	kW	giri/min rpm		kgm ²	100%	75%	50%	100%	75%	50%	A	Nm	Ca/Cn Tst/Tn	Ia/In Ist/In	Cmax/Cn Tmax/Tn	dB (A)
Serie C3A (carcassa in alluminio) - C3A Series (aluminium frame)																
C3A 80-b	0.75	1360	0.0019	82.5	79	78	0.73	0.69	0.58	1.8	5.27	2.3	5	2.3	50	11
C3A 90S	1.1	1428	0.0034	84.1	83	79	0.74	0.64	0.48	2.6	7.36	2.8	5.8	3.1	51	16
C3A 90L	1.5	1430	0.0040	85.3	84	81	0.75	0.65	0.5	3.4	10.02	3	6	3.2	51	18.4
C3A 100L-a	2.2	1435	0.0083	86.7	86.3	84.3	0.75	0.66	0.52	4.9	14.64	2.7	6.4	3.4	54	26.2
C3A 100L-b	3	1425	0.0097	85.5	85.8	84.9	0.78	0.73	0.62	6.5	20.10	2.8	6.6	3.5	54	29
C3A 112M	4	1435	0.0198	88.6	88.3	87.0	0.78	0.70	0.56	8.4	26.62	2.8	6.5	3	54	48
C3A 132sa	5.5	1463	0.033	89.6	89.6	88.4	0.78	0.70	0.56	11.4	35.9	2.3	6.5	2.8	54	58
C3A 132Ma	7.5	1463	0.037	90.4	90.0	88.0	0.78	0.70	0.57	15.37	49.0	2.2	6.5	2.8	54	65
C3A 160M	11	1470	0.092	91.4	91.4	91.0	0.81	0.75	0.62	21.5	71.5	2.8	6.3	2.7	58	104
C3A 160L	15	1470	0.108	92.1	92.0	91.8	0.84	0.79	0.70	28.0	97.4	2.8	6.3	2.6	62	125
C3A 180MT	18.5	1470	0.117	92.6	92.2	92.0	0.8	0.79	0.68	35	120.2	2.8	6.3	2.6	62	133
C3A 180L	22	1471	0.194	93	92.7	91.3	0.82	0.77	0.65	42	142.8	2.8	7.4	3.2	62	180
C3A 200L	30	1471	0.373	93.6	93.4	92.6	0.86	0.82	0.70	54	194.7	2.8	7.4	3	64	230
C3A 225ST	37	1473	0.397	93.9	93.4	92.6	0.86	0.82	0.7	66	239.9	2.8	7.8	3.2	64	242
C3A 225M	45	1476	0.549	94.2	94.0	93.3	0.88	0.84	0.73	78	291	3	8	3.4	64	310
C3A 250M	55	1480	0.977	94.6	94.4	93.8	0.88	0.84	0.77	95	355	2.6	6.4	2.6	65	360
C3A 280ST	75	1480	1.486	95	94.8	94.5	0.88	0.85	0.78	130	484	2.8	6.5	2.6	69	474
C3A 280MT	90	1482	1.720	95.2	95.1	94.5	0.88	0.85	0.78	155	580	2.8	6.8	2.7	69	532
C3A 315S	110	1484	3.310	95.4	95.4	94.6	0.88	0.86	0.80	189	708	2.5	7	2.5	78	733
C3A 315M-b	132	1487	3.310	95.5	95.8	95.4	0.88	0.86	0.80	227	848	2.4	7	2.5	78	733
C3A 315M-c	160	1485	3.972	95.8	95.8	95.3	0.88	0.86	0.80	274	1029	2.7	7.6	2.7	78	848
C3A 315M-d	200	1486	4.800	96.0	95.9	95.6	0.88	0.86	0.78	342	1285	2.7	8.2	2.9	78	1026
Serie C3S (carcassa in acciaio) - C3S Series (steel frame)																
C3S 355L-b	250	1488	4.760	96.0	96.0	95.2	0.88	0.86	0.77	428	1604	2.6	7	2.5	84	1480
C3S 355L-c	315	1488	5.752	96	96	95.5	0.88	0.87	0.80	539	2021	2.6	7	2.5	84	1680
C3S 355Lx-a	355	1492	11.657	96	96	95.6	0.89	0.88	0.83	600	2272	2	6.2	2.4	84	1960

I valori di rendimento sono calcolati in accordo con IEC 60034-2-1.

Efficiency values are given according to IEC 60034-2-1.

Dati tecnici

Classe di efficienza IE3 (IEC 60034-30; 2008)

Efficienza Premium

Isolamento classe F - Sovratemperatura classe B

Servizio S1 - 400 V - 50 Hz

6 poli - 1.000 giri/min

Technical data

IE3 Efficiency class (IEC 60034-30; 2008)

Premium Efficiency

Insulation class F - Temperature rise class B

S1 Duty - 400 V - 50 Hz

6 poles - 1.000 rpm

Tipo Type	Potenza Power	Velocità Speed	J	Rendimento Efficiency			Fattore di potenza Power factor cosφ			Corrente Current In (400 V)	Coppia nom. Nom. torque	Coppia di spunto Starting torque	Corrente di spunto Starting current	Coppia massima Max torque	Rumor. Noise	Forma B3 Mount B3 Peso Weight
	kW	giri/min rpm		kgm²	100%	75%	50%	100%	75%	50%	A	Nm	Ca/Cn Tst/Tn	Ia/In Ist/In	Cmax/Cn Tmax/Tn	dB (A)
Serie C3A (carcassa in alluminio) - C3A Series (aluminium frame)																
C3A 90S	0.75	926	0.0060	78.9	77	72	0.67	0.56	0.42	2.05	7.7	2.8	4.8	2.9	54	11
C3A 90L	1.1	925	0.0072	81	80	77	0.69	0.58	0.44	2.8	11.4	3	5	3.2	54	13.6
C3A 100L	1.5	950	0.0134	82.5	81	77	0.69	0.58	0.44	3.8	15.1	2.4	5.2	2.8	56	25
C3A 112M	2.2	950	0.0242	84.3	83.5	81	0.72	0.63	0.5	5.2	22.1	2.3	5.8	2.6	56	44
C3A 132S	3	954	0.0389	85.6	85.5	84	0.75	0.67	0.53	6.8	30.0	2.2	6	2.8	59	52.5
C3A 132M-a	4	956	0.0511	86.8	86.8	85.6	0.76	0.67	0.53	8.8	40.0	2.3	6	2.9	59	69
C3A 132M-b	5.5	957	0.0584	88	87.6	86.4	0.76	0.67	0.53	11.9	54.9	2.4	6.3	3	59	77
C3A 160M	7.5	960	0.135	89.1	89	88.9	0.82	0.76	0.63	14.8	74.6	2.6	7.5	2.9	63	104
C3A 160L	11	965	0.159	90.3	90.2	89.6	0.8	0.73	0.6	22.0	108.8	2.7	7.8	3	63	125
C3A 180L	15	981	0.330	91.2	91.2	90.0	0.8	0.73	0.62	28.3	146	2.8	6.5	2.8	63	163
C3A 200LT	18.5	981	0.377	91.7	91.6	91.3	0.85	0.80	0.68	34.3	180	2.7	6.7	2.8	68	180
C3A 200L-b	22	982	0.483	92.2	92.2	91.6	0.85	0.80	0.68	41	214	2.8	7	2.9	70	210
C3A 225M	30	983	0.92	92.9	92.7	92.4	0.85	0.80	0.69	55	291	2.7	7	2.9	72	310
C3A 250M	37	992	1.72	93.3	93.2	92.2	0.83	0.78	0.69	69	356	2.8	7	2.4	75	340
C3A 280ST	45	993	2.17	93.7	93.6	92.4	0.83	0.78	0.70	84	433	3	7.8	2.5	75	435
C3A 280MT	55	985	2.68	94.1	94.1	93.6	0.83	0.78	0.67	102	533	3	7.3	2.8	75	514
C3A 315S	75	988	3.14	94.6	94.4	93.7	0.84	0.78	0.68	136	725	2.5	6	2.3	82	672
C3A 315M-a	90	989	3.63	94.9	94.8	93.7	0.84	0.78	0.68	163	869	2.5	7	2.7	82	730
C3A 315M-b	110	989	4.71	95.1	95	94.4	0.84	0.79	0.69	199	1062	2.5	7	2.8	82	919
C3A 315M-d	132	989	5.69	95.4	95.3	94.9	0.84	0.8	0.721	238	1274	2.6	7	2.9	82	1100
Serie C3S (carcassa in acciaio) - C3S Series (steel frame)																
C3S 355L-a	160	990	6.39	94.8	94.4	93.5	0.84	0.81	0.7	290	1543	1.8	5.8	2.4	82	1300
C3S 355L-b	200	990	7.98	95.8	95.3	94.7	0.86	0.83	0.75	351	1929	1.8	5.8	2.4	82	1584
C3S 355L-c	250	990	8.71	95.8	95.6	95	0.86	0.83	0.75	439	2411	1.9	6	2.5	82	1744
C3S 355Lx-a	280	992	11.50	95.8	95.7	95.1	0.83	0.8	0.72	509	2695	1.9	5.6	1.9	82	1960
C3S 355Lx-b	315	992	13.18	95.8	95.8	95.4	0.83	0.81	0.74	572	3032	1.9	5.6	1.9	82	2060
C3S 355Lx-c	355	992	14.38	95.8	95.8	95.7	0.83	0.81	0.74	645	3417	2	5.6	2	82	2200

I valori di rendimento sono calcolati in accordo con IEC 60034-2-1.

Efficiency values are given according to IEC 60034-2-1.

Dati tecnici

Servizio S1 - 400 V - 50 Hz

A due polarità - avvolgimento unico - DAHLANDER

2-4 poli - 3.000-1.500 giri/min

Technical data

S1 Duty - 400 V - 50 Hz

Double polarity - single winding - DAHLANDER

2-4 poles - 3.000-1.500 rpm

Tipo Type	Potenza Power		Velocità Speed		J	Rendimento Efficiency		Fattore di potenza Power factor		Corrente Current In (400 V)		Coppia nom. Nom. torque		Coppia di spunto Starting torque		Corrente di spunto Starting current		Coppia massima Max torque		Forma B3 Mount B3 Peso Weight
	kW		giri/min rpm			kgm ²	%		cosφ		A		Nm		Ca/Cn Tst/Tn		Ia/In Ist/In		Cmax/Cn Tmax/Tn	
	2p	4p	2p	4p	2p		4p	2p	4p	2p	4p	2p	4p	2p	4p	2p	4p	2p	4p	
Serie CA (carcassa in alluminio) - CA Series (aluminium frame)																				
CA 63	0.22	0.15	2690	1340	0.00029	61	59	0.86	0.67	0.61	0.55	0.78	1.07	1.7	1.4	4	3	1.8	1.6	4.1
CA 71	0.3	0.22	2760	1350	0.00035	67	61	0.86	0.73	0.75	0.71	1.04	1.6	1.7	1.4	3.7	3	1.8	1.6	5.7
CA 71	0.45	0.3	2790	1370	0.00052	69	61	0.86	0.73	1.10	0.97	1.54	2.1	1.8	1.7	4.6	3.2	2	1.7	7
CA 80	0.55	0.45	2820	1380	0.0012	69	69	0.86	0.75	1.34	1.26	1.86	3.1	2.2	1.7	5.1	3.2	2.4	1.8	8.4
CA 80	0.75	0.6	2830	1410	0.0017	71	67	0.86	0.75	1.8	1.7	2.53	4.1	2.6	1.8	6.3	3.6	2.9	2	10
CA 90S	1.25	0.95	2830	1380	0.0022	72	68	0.86	0.82	2.9	2.5	4.22	6.6	2	1.5	5	3.3	2.2	1.7	11.9
CA 90L	1.7	1.32	2840	1400	0.0028	73	70	0.86	0.83	3.9	3.3	5.72	9.0	2.1	1.6	5	3.4	2.3	1.8	14.2
CA 100L	2.4	1.84	2840	1400	0.0057	73	76	0.86	0.84	5.5	4.2	8.07	12.6	1.9	1.7	4.7	4.6	2.1	1.8	20
CA 100L	3.3	2.6	2850	1420	0.0078	74	78	0.86	0.85	7.5	5.7	11.1	17.5	2	1.8	5.2	4.8	2.2	1.9	22.4
CA 112MT	4.5	4	2870	1420	0.0092	76	78.5	0.86	0.86	9.9	7.9	15	24.9	2	1.8	5.5	4.9	2.2	2	27
CA 132S	6	5	2870	1440	0.021	79	82	0.84	0.86	13.1	10.2	20	33.2	2	1.5	5.5	5.3	2.2	1.9	43
CA 132M	8	6.6	2875	1440	0.028	82	84	0.84	0.86	16.8	13.2	26.6	43.8	2	1.6	6.2	5.4	2.2	2	50.3
CA 160MT	11	9	2920	1450	0.039	84	84	0.85	0.82	22	18.5	36	58.0	2	1.6	7.3	5.8	2.3	2	69.5
CA 160L	15	12	2920	1450	0.080	86	84	0.87	0.83	29	25	49.1	79.1	2.4	1.7	6.7	5.5	2.4	2	89
CA 180MT	18.5	15	2930	1460	0.098	87	87	0.87	0.83	35	30	60.3	98.1	2.3	2.2	7.3	5.4	2.7	2.2	110
CA 180LT	22	18.5	2940	1460	0.124	87	89	0.87	0.83	42	36	71.5	121	2.5	2.3	7.5	5.5	2.8	2.3	128
CA 200LT	30	22	2940	1460	0.180	87	89	0.89	0.87	56	41	97.5	144	2.6	2	7.9	6.7	2.4	2.1	170
CA 225ST	37	30	2945	1460	0.345	88	89	0.89	0.87	68	56	120	196	2.2	2.2	8.3	6.3	2.5	2.2	220
CA 225MT	45	37	2945	1470	0.419	88	90	0.89	0.87	83	68	146	240	2.2	2.3	8.3	6.3	2.5	2.2	250
CA 250MT	55	45	2950	1470	0.541	89	89	0.90	0.87	99	84	178	292	2.3	2.3	8.3	6.4	2.5	2.1	340
CA 280ST	66	55	2960	1480	1.10	89	91	0.90	0.88	119	99	213	355	2.3	2.3	8.4	6	2.4	2.2	415
CA 280MT	85	70	2960	1480	1.43	90	92	0.90	0.89	152	124	274	452	2.2	2.2	8.2	6	2.4	2.1	470
CA 315M	96	80	2975	1480	2.88	90	92	0.89	0.90	173	140	308	516	2.4	2.1	8	6	2.5	2.2	590
CA 315M	110	96	2978	1480	2.58	90	92	0.88	0.90	201	168	353	620	2.5	2.3	8	6.1	2.6	2.2	650
CA 315M	132	110	2980	1480	3.06	90	92	0.88	0.90	241	192	423	710	2.5	2.3	8	6.3	2.6	2.3	740
CA 315M	160	132	2980	1480	3.71	90	92.3	0.89	0.90	289	230	513	852	2.5	2.3	8	6.5	2.6	2.3	870

Dati tecnici

Servizio S1 - 400 V - 50 Hz
A due polarità - avvolgimento unico - DAHLANDER
4-8 poli - 1.500-750 giri/min

Technical data

S1 Duty - 400 V - 50 Hz
Double polarity - single winding - DAHLANDER
4-8 poles - 1.500-750 rpm

Tipo Type	Potenza Power		Velocità Speed		J	Rendimento Efficiency		Fattore di potenza Power factor		Corrente Current In (400 V)		Coppia nom. Nom. torque		Coppia di spunto Starting torque		Corrente di spunto Starting current		Coppia massima Max torque		Forma B3 Mount B3 Peso Weight
	kW		giri/min rpm			kgm ²	%		cosφ		A		Nm		Ca/Cn Tst/Tn		Ia/In Ist/In		Cmax/Cn Tmax/Tn	
	4p	8p	4p	8p	4p		8p	4p	8p	4p	8p	4p	8p	4p	8p	4p	8p	4p	8p	
Serie CA (carcassa in alluminio) - CA Series (aluminium frame)																				
CA 63	0.11	0.06	1330	660	0.00039	50	25	0.66	0.52	0.48	0.67	0.79	0.87	2.0	1.8	3	2.5	1.9	1.7	5.2
CA 71	0.18	0.11	1330	660	0.00129	52	41	0.68	0.53	0.74	0.73	1.29	1.59	2.2	1.8	3.6	2.2	2.2	1.9	5.8
CA 80	0.25	0.15	1350	680	0.00164	56	44	0.77	0.60	0.84	0.82	1.77	2.11	1.5	1.5	4	3	1.9	2	7.4
CA 80	0.45	0.25	1360	680	0.00256	67	52	0.78	0.60	1.24	1.16	3.16	3.51	1.6	1.6	4	3	2.2	2.1	9.8
CA 90S	0.55	0.3	1400	690	0.00303	67	53	0.83	0.63	1.43	1.3	3.75	4.15	1.5	1.7	4	3.5	1.7	1.8	10.5
CA 90L	0.80	0.45	1400	695	0.0045	67	53	0.83	0.63	2.08	1.95	5.46	6.18	1.6	1.6	3.8	3	1.8	1.9	13.5
CA 100L	1.25	0.6	1400	700	0.0087	69	56	0.82	0.58	3.19	2.67	8.53	8.19	1.6	1.5	4.5	3.5	2	1.7	19.6
CA 100L	1.76	0.88	1400	700	0.0109	71	58	0.82	0.58	4.37	3.78	12	12	1.6	1.5	5	3.7	2	1.7	21.5
CA 112MT	2.2	1.5	1420	700	0.0141	75	64	0.82	0.68	5.17	4.98	14.8	20.5	1.6	1.6	5	3.6	2	1.6	25
CA 132S	3.3	2.2	1430	705	0.0307	76	70	0.82	0.69	7.65	6.58	22	29.8	1.6	1.5	5.2	4	2	1.6	45.5
CA 132M	4.5	3	1430	705	0.041	82	77	0.82	0.69	9.67	8.16	30.1	40.6	2	1.6	6.7	4.2	2.1	1.7	52.5
CA 160MT	5.5	4	1440	710	0.054	82	77	0.81	0.69	12	10.9	36.5	53.8	2.1	1.7	7.6	4.6	2.3	2.2	69
CA 160M	7.5	5	1440	710	0.077	82	79	0.89	0.78	14.9	11.7	49.8	67.3	1.7	1.6	6.6	4.5	2.3	2.1	70
CA 160L	10	7	1450	715	0.109	84	82	0.90	0.78	19.1	15.8	65.9	93.5	1.8	1.9	5.5	5	2.3	2.1	88
CA 180LT	15	9.5	1450	715	0.141	87	85	0.90	0.79	27.7	20.4	98.8	127	1.6	1.6	5.6	4.8	1.8	1.8	114
CA 200LT	22	15	1460	720	0.394	88	85	0.90	0.74	40.1	34.5	144	199	2.3	2.4	7.5	6	2.7	2.2	160
CA 225ST	26	18.5	1460	720	0.541	88	86	0.90	0.70	47.4	44.4	170	245	2.3	2.4	7.8	6.3	2.7	2.2	234
CA 225MT	30	22	1460	720	0.631	88	87	0.91	0.70	54.1	52.2	196	292	2.5	2.4	8.2	6.5	2.6	2.2	254
CA 250MT	37	30	1470	730	0.963	89	89	0.90	0.80	66.8	60.9	240	393	2.2	1.9	8	6	2.1	2.0	295
CA 280ST	48	37	1470	730	1.75	91	90	0.90	0.78	84.7	76.2	312	484	2	2	6.3	5	2	1.9	430
CA 280MT	60	45	1480	740	2.18	92	91	0.90	0.78	105	91.6	390	589	2.2	2.1	6.5	5	2.1	2.0	480
CA 315ST	75	55	1480	740	2.43	90	90	0.82	0.66	147	134	484	710	1.8	1.6	5.8	4.3	2	1.8	540
CA 315M	90	70	1480	740	4.27	90	91	0.89	0.74	162	150	581	904	1.8	1.6	6	4.5	2	1.8	680
CA 315M	110	77	1485	740	4.91	90	91	0.89	0.74	198	165	710	994	1.7	1.4	6	4.5	1.9	1.7	750
CA 315M	128	90	1485	740	5.95	91	91	0.88	0.72	231	199	823	1162	1.8	1.5	6.2	5	1.9	1.8	880
CA 355LT	150	110	1485	745	7.37	91	91	0.88	0.72	271	243	965	1420	1.5	1.4	6.5	5.5	1.7	1.7	1100

Dati tecnici

Servizio S1 - 400 V - 50 Hz
A due polarità - due avvolgimenti separati
4-6 poli - 1.500-1.000 giri/min

Technical data

S1 Duty - 400 V - 50 Hz
Double polarity - two separate windings
4-6 poles - 1.500-1.000 rpm

Tipo Type	Potenza Power		Velocità Speed		J	Rendimento Efficiency		Fattore di potenza Power factor		Corrente Current In (400 V)		Coppia nom. Nom. torque		Coppia di spunto Starting torque		Corrente di spunto Starting current		Coppia massima Max torque		Forma B3 Mount B3 Peso Weight
	kW		giri/min rpm			kgm ²	%		cosφ		A		Nm		Ca/Cn Tst/Tn		Ia/In Ist/In		Cmax/Cn Tmax/Tn	
	4p	6p	4p	6p	4p		6p	4p	6p	4p	6p	4p	6p	4p	6p	4p	6p	4p	6p	
Serie CA (carcasa in alluminio) - CA Series (aluminium frame)																				
CA 63	0.11	0.08	1400	900	0.00039	43	30	0.67	0.65	0.55	0.56	0.75	0.8	1.8	2	3	2.7	1.9	2	5.2
CA 71	0.22	0.15	1400	900	0.00129	52	45	0.70	0.68	0.87	0.71	1.5	1.59	1.8	1.9	3	2.7	1.9	2	6.5
CA 80	0.30	0.22	1400	900	0.00164	52	47	0.78	0.78	1.07	0.87	2.05	2.33	1.7	1.6	3.2	3	1.8	1.7	7.4
CA 80	0.45	0.3	1400	900	0.00256	52	50	0.75	0.70	1.67	1.24	3.07	3.18	1.5	1.4	3.2	3	1.7	1.7	9.8
CA 90S	0.66	0.45	1400	900	0.00354	54	50	0.72	0.65	2.45	2	4.5	4.78	1.6	1.6	4.5	4	1.8	1.8	13.5
CA 90L	0.88	0.6	1380	890	0.00505	55	51	0.73	0.67	3.17	2.5	6.09	6.44	1.7	1.7	4.8	4.3	1.9	1.9	14.5
CA 100L	1.32	0.88	1420	940	0.0087	64	57	0.87	0.75	3.43	3.0	8.88	8.94	1.2	1.2	4	3.5	1.6	1.6	19.6
CA 100L	1.76	1.2	1430	945	0.012	66	63	0.87	0.75	4.43	3.7	11.8	12.1	1.2	1.3	4	3.5	1.6	1.6	22
CA 112MT	2.2	1.5	1430	940	0.014	73	64	0.80	0.70	5.44	4.8	14.7	15.2	1.4	1.6	5	4	1.7	1.7	25
CA 132S	3.3	2.2	1430	940	0.031	81	77	0.80	0.75	7.36	5.5	22	22.4	1.8	1.6	6.8	5	2.2	2.1	45
CA 132M	4.5	3	1450	950	0.041	81	79	0.80	0.74	10	7.4	29.6	30.2	2.0	1.6	7	5	2.3	2.2	52
CA 160MT	6.6	4.5	1440	955	0.054	84	81	0.84	0.78	13.5	10.3	43.8	45	1.5	1.6	7	6	2.3	2.3	70
CA 160L	8.8	6	1450	955	0.109	84	81	0.85	0.79	17.8	13.5	58	60	1.6	1.7	7	6	2.2	2.3	87.5
CA 180MT	11	7.5	1450	955	0.129	84	81	0.85	0.79	22.3	16.9	72.5	75	1.7	1.8	7.2	6.2	2.3	2.4	110
CA 180LT	15	8.8	1460	970	0.167	85	82	0.88	0.80	29	19.4	98.1	86.7	1.8	1.7	6.5	6	2.3	2.4	122
CA 200LT	18.5	12.5	1460	970	0.180	85	82	0.81	0.76	38.8	29	121	123	1.7	1.5	6.3	5	2.3	2	172
CA 200LT	22	15	1460	975	0.206	85	82	0.82	0.78	45.6	33.9	144	147	2.1	1.6	7.2	5	2.7	2.2	194
CA 225ST	26	18.5	1460	975	0.370	86	83	0.83	0.79	52.6	40.8	170	181	2.5	2	7.5	6	2.8	2.4	235
CA 225MT	30	22	1460	975	0.419	86	83	0.83	0.79	60.7	48.5	196	216	2.6	2	7.7	6.2	2.9	2.5	260
CA 250MT	37	26	1470	980	0.577	87	84	0.84	0.80	73.2	55.9	240	253	1.6	1.8	6.8	6.3	1.8	2	330
CA 280ST	50	37	1470	980	1.23	89	86	0.85	0.80	95.5	77.7	325	361	1.7	1.9	7	6.5	1.9	2.1	430
CA 280MT	63	45	1480	985	1.47	90	87	0.86	0.80	118	93.4	407	436	1.8	2	7.5	7	2	2.2	470
CA 315M	75	55	1480	985	3.50	90	90	0.84	0.76	143	116	484	533	2	2.5	6	5	2.2	2.7	710
CA 315M	90	65	1480	985	4.63	90	90	0.84	0.76	172	137	581	630	2	2.4	6.5	6	2.2	2.6	910
CA 315M	110	80	1485	985	5.45	90	90	0.84	0.76	210	169	708	776	2	2.4	6.7	6.2	2.2	2.6	1100
CA 315M	132	96	1485	985	5.87	90	90	0.85	0.77	249	200	849	931	2.1	2.5	6.8	6.3	2.3	2.6	1180

Dati tecnici

Servizio S1 - 400 V - 50 Hz
A due polarità - due avvolgimenti separati
6-8 poli - 1.000-750 giri/min

Technical data

S1 Duty - 400 V - 50 Hz
Double polarity - two separate windings
6-8 poles - 1.000-750 rpm

Tipo Type	Potenza Power		Velocità Speed		J	Rendimento Efficiency		Fattore di potenza Power factor		Corrente Current In (400 V)		Coppia nom. Nom. torque		Coppia di spunto Starting torque		Corrente di spunto Starting current		Coppia massima Max torque		Forma B3 Mount B3 Peso Weight	
	kW		giri/min rpm		kgm ²	%		cosφ		A		Nm		Ca/Cn Tst/Tn		Ia/In Ist/In		Cmax/Cn Tmax/Tn		kg	
	6p	8p	6p	8p		6p	8p	6p	8p	6p	8p	6p	8p	6p	8p	6p	8p	6p	8p		
Serie CA (carcassa in alluminio) - CA Series (aluminium frame)																					
CA 63	0.07	0.05	860	650	0.00039	36	30	0.65	0.63	0.43	0.38	0.76	0.71	1.3	1.3	2	1.8	1.5	1.5	5.2	
CA 71	0.11	0.075	880	670	0.00129	41	33	0.67	0.60	0.58	0.55	1.19	1.07	1.3	1.3	2	1.9	1.5	1.5	6.5	
CA 80	0.18	0.11	880	670	0.00164	44	35	0.69	0.68	0.86	0.67	1.95	1.57	1.3	1.3	2.5	2.4	1.5	1.5	7.6	
CA 80	0.25	0.18	880	670	0.00256	49	41	0.70	0.69	1.05	0.92	2.68	2.53	1.5	1.5	2.8	2.6	1.7	1.6	9.8	
CA 90S	0.37	0.25	890	680	0.00354	58	46	0.72	0.71	1.28	1.11	3.97	3.51	1.5	1.4	3	2.7	1.8	1.7	11	
CA 90L	0.55	0.37	890	680	0.00505	64	52	0.73	0.72	1.70	1.43	5.84	5.12	1.5	1.4	3	2.8	1.9	1.7	14	
CA 100L	0.75	0.55	900	690	0.0087	66	58	0.74	0.74	2.22	1.85	7.62	7.61	1.6	1.4	3	2.8	1.9	1.7	19.6	
CA 100L	1.03	0.75	940	690	0.012	66	60	0.76	0.76	2.97	2.38	10.5	10.4	1.6	1.4	3.5	3	2	1.8	23.5	
CA 112MT	1.25	0.95	940	690	0.014	72	62	0.71	0.68	3.53	3.26	12.7	13	1.7	1.6	4.2	3.5	2.1	1.9	26	
CA 132S	2.2	1.5	940	700	0.031	75	64	0.70	0.70	6.06	4.84	22.1	20.3	1.8	1.6	5.2	3.7	2.3	2	45.5	
CA 132M	3	1.85	950	705	0.041	76	67	0.70	0.70	8.15	5.7	30.2	25.1	1.8	1.6	5.4	4.5	2.3	2	56	
CA 160MT	3.7	2.6	950	705	0.054	78	70	0.74	0.71	9.26	7.6	37	35	1.8	1.5	6	4.5	2.5	1.9	69	
CA 160M	4.5	3.3	955	710	0.077	79	72	0.78	0.72	10.6	9.2	44.8	44.4	1.8	1.7	6	4.8	2.5	2	71	
CA 160L	6	4.5	960	710	0.109	80	74	0.79	0.73	13.7	12	59.7	60.5	1.8	1.7	6	4.8	2.5	2	88	
CA 180MT	7.5	5.5	960	710	0.14	82	81	0.82	0.68	16.1	14.4	74.6	73.5	1.9	1.8	6	5	2.5	2	110	
CA 180LT	9.5	7.5	960	715	0.17	82	81	0.82	0.70	20.4	19.1	93.6	100	1.9	1.8	6.3	5.3	2.6	2.1	124	
CA 200LT	12	8.8	970	715	0.32	82	78	0.78	0.68	27.1	24	118	118	2.1	2	7	5.5	2.7	2.2	175	
CA 200LT	15	11	970	715	0.39	84	79	0.79	0.70	32.7	28.7	147	146	2.1	2	7.2	5.7	2.7	2.2	200	
CA 225MT	18.5	14	975	720	0.58	88	88	0.79	0.72	38.5	31.9	180	186	2	2	7	6.2	2.5	2	252	
CA 250MT	22	16	980	720	0.84	88	88	0.81	0.73	44.6	36	214	212	2.3	1.8	7.3	6.3	2.7	2.1	305	
CA 250MT	26	18.5	980	720	0.96	89	89	0.81	0.75	52.1	40.1	253	242	2.3	1.9	7.3	6.4	2.8	2.2	348	
CA 280ST	30	22	980	730	1.7	90	90	0.81	0.76	59.5	46.5	291	288	2.4	2.1	6.3	5	2.8	2.2	430	
CA 280MT	40	30	985	730	2.1	90	90	0.82	0.76	78.3	63.4	388	387	2.3	2.2	6	5	2.7	2.1	475	
CA 315ST	50	37	985	740	2.4	90	90	0.82	0.76	97.9	78.2	485	478	2.2	1.6	5.8	5	2.6	1.9	528	
CA 315M	60	45	985	740	3.9	90	90	0.83	0.77	116	93.8	579	581	2.3	1.6	6	5.2	2.2	1.7	671	
CA 315M	75	55	990	740	4.5	90	90	0.83	0.77	145	115	724	710	2.4	1.7	6.3	5.4	2.2	1.9	750	
CA 315M	96	75	990	740	5.9	90	90	0.83	0.77	186	156	926	968	2.4	1.7	6.6	5.4	2.2	1.9	870	
CA 355LT	110	85	990	740	7.4	90	90	0.84	0.78	210	175	1061	1097	2	1.6	6.5	5.5	2.1	1.8	1020	

Dati tecnici

Servizio S1 - 400 V - 50 Hz
A due polarità - due avvolgimenti separati
2-8 poli - 3.000-750 giri/min

Technical data

S1 Duty - 400 V - 50 Hz
Double polarity - two separate windings
2-8 poles - 3.000-750 rpm

Tipo Type	Potenza Power		Velocità Speed		J	Rendimento Efficiency		Fattore di potenza Power factor		Corrente Current In (400 V)		Coppia nom. Nom. torque		Coppia di spunto Starting torque		Corrente di spunto Starting current		Coppia massima Max torque		Forma B3 Mount B3 Peso Weight
	kW		giri/min rpm			kgm ²	%		cosφ		A		Nm		Ca/Cn Tst/Tn		Ia/In Ist/In		Cmax/Cn Tmax/Tn	
	2p	8p	2p	8p	2p		8p	2p	8p	2p	8p	2p	8p	2p	8p	2p	8p	2p	8p	
Serie CA (carcassa in alluminio) - CA Series (aluminium frame)																				
CA 63	0.18	0.045	2700	600	0.00029	51	20	0.76	0.56	0.67	0.58	0.64	0.72	1.5	1.6	3	2	1.7	1.8	5
CA 71	0.25	0.06	2690	650	0.00052	62	20	0.78	0.58	0.75	0.75	0.89	0.88	1.7	2	3	2	1.8	2	5.8
CA 80	0.37	0.08	2745	660	0.0016	65	30	0.76	0.48	1.08	0.8	1.29	1.16	1.7	2	3.2	2.2	1.9	2.1	7.4
CA 80	0.55	0.11	2750	670	0.0026	67	32	0.78	0.50	1.52	1	1.91	1.57	1.8	2.1	3.3	2.3	1.9	2.1	9.8
CA 90S	0.75	0.18	2780	670	0.0035	67	38	0.79	0.52	2.05	1.32	2.58	2.57	2.2	2.2	3.5	2.5	2.4	2.3	10.8
CA 90L	1.1	0.3	2790	680	0.0051	67	42	0.80	0.54	2.97	1.91	3.77	4.21	2.1	2	3.5	2.5	2.3	2.2	13.5
CA 100L	1.5	0.37	2800	700	0.0087	67	46	0.86	0.56	3.76	2.08	5.12	5.05	2.1	2.6	4.4	2.9	2.3	2.7	19.6
CA 100L	2.2	0.55	2800	710	0.013	68	47	0.87	0.58	5.37	2.92	7.51	7.4	2.2	2.7	4.5	3	2.4	2.9	23.5
CA 112MT	2.6	0.75	2840	710	0.014	71	54	0.88	0.60	6.01	3.35	8.74	10.1	1.7	1.8	5	3.5	1.9	2	25
CA 112M	3	0.9	2830	690	0.015	73	58	0.86	0.58	6.91	3.87	9.95	12.3	1.7	1.7	5.3	3.8	1.9	1.9	37
CA 132S	3.7	1.1	2880	700	0.024	81	60	0.83	0.56	7.95	4.73	12.2	15	1.7	1.6	6.8	4	1.8	1.8	47.5
CA 132M	5.5	1.5	2900	700	0.034	82	61	0.84	0.57	11.5	6.23	18.1	20.3	1.8	1.7	7	4	1.9	1.9	55.8
CA 160M	7.5	2.2	2900	705	0.062	80	73	0.87	0.56	15.6	7.78	24.5	29.6	1.7	2.4	6	4	2	2.6	76
CA 160L	9.5	3	2920	710	0.080	82	73	0.87	0.56	19.2	10.6	31.1	40.4	2.3	2.7	7	4.5	2.3	2.7	89
CA 180MT	11	3.7	2920	710	0.098	83	74	0.87	0.56	22	12.9	36	49.1	2.3	2.7	7	4.5	2.3	2.7	110
CA 180LT	15	4.5	2920	720	0.12	87	75	0.89	0.50	28	17.3	49.1	59.7	2.2	2.7	7	4.5	2.3	2.7	122
CA 200LT	18.5	5.5	2920	720	0.16	83	75	0.89	0.60	36.2	17.7	60.2	73	1.9	2.0	6	4.5	2	2.1	162
CA 225ST	22	7.5	2935	720	0.34	83	78	0.86	0.60	44.5	23.2	71.5	99.5	2.3	2.3	7.6	4.9	2.3	2.3	210
CA 225MT	26	8.8	2940	720	0.39	84	79	0.87	0.60	51.4	26.8	84.8	117	2.5	2.5	8	5	2.5	2.5	235
CA 250MT	30	11	2930	720	0.41	84	82	0.88	0.64	58.6	30.3	97.8	146	2.1	2.4	7	5	2.2	2.5	280
CA 250MT	37	15	2930	720	0.54	84	87	0.90	0.68	70.7	36.6	120	199	2.1	2.4	7.2	5.3	2.2	2.5	317
CA 280ST	45	18.5	2950	720	1.15	85	88	0.90	0.63	85	48.2	145	242	2.2	2.1	7.6	4.6	2.2	2.3	387
CA 280MT	55	22	2960	730	1.43	87	89	0.90	0.64	102	55.8	179	288	2.2	2.1	8	4.8	2.2	2.3	470
CA 315ST	65	26	2940	730	0.85	87	88	0.88	0.62	123	68.9	210	336	1.8	1.9	6.8	5	2	2.1	510
CA 315M	80	33	2960	740	1.63	87	88	0.88	0.62	151	87.4	258	426	1.8	1.9	6.8	5	2	2.1	670
CA 315M	110	45	2960	740	2.03	88	89	0.89	0.63	203	116	355	581	1.9	2	7	5.3	2	2.1	740
CA 355LT	130	70	2960	740	2.90	88	89	0.87	0.61	245	186	420	904	1.9	2	7.2	5.6	2	2.1	1020

Dati tecnici

Technical data

Per ventilatori

Servizio S1 - 400 V - 50 Hz

A due polarità - avvolgimento unico - DAHLANDER

2-4 poli - 3.000-1.500 giri/min

For fans

S1 Duty - 400 V - 50 Hz

Double polarity - single winding - DAHLANDER

2-4 poles - 3.000-1.500 rpm

Tipo Type	Potenza Power		Velocità Speed		J	Rendimento Efficiency		Fattore di potenza Power factor		Corrente Current In (400 V)		Coppia nom. Nom. torque		Coppia di spunto Starting torque		Corrente di spunto Starting current		Coppia massima Max torque		Forma B3 Mount B3 Peso Weight
	kW		giri/min rpm		kgm ²	%		cosφ		A		Nm		Ca/Cn Tst/Tn		Ia/In Ist/In		Cmax/Cn Tmax/Tn		kg
	2p	4p	2p	4p		2p	4p	2p	4p	2p	4p	2p	4p	2p	4p	2p	4p	2p	4p	
Serie CA (carcassa in alluminio) - CA Series (aluminium frame)																				
CA 63	0.22	0.044	2670	1130	0.00024	58	53	0.87	0.75	0.63	0.16	0.79	0.32	1.4	1.5	3	2.6	1.5	1.6	3.8
CA 63	0.26	0.051	2680	1340	0.00029	60	56	0.87	0.75	0.72	0.18	0.93	0.36	1.4	1.5	3	2.6	1.5	1.6	4.1
CA 71	0.37	0.075	2750	1370	0.00035	70	56	0.88	0.78	0.87	0.25	1.29	0.5	1.4	1.8	3	2.6	1.5	1.9	5.7
CA 71	0.55	0.11	2780	1390	0.00052	71	60	0.88	0.78	1.27	0.34	1.89	0.8	1.5	2	3.8	3.7	1.7	2.2	7
CA 80	0.75	0.15	2810	1405	0.0015	71	66	0.86	0.75	1.78	0.44	2.55	1.0	1.7	1.9	3.8	3.5	1.8	2	8.4
CA 80	0.95	0.25	2820	1415	0.0017	71	69	0.84	0.80	2.3	0.7	3.22	1.7	2.2	2	5	4.3	2.3	2.1	10
CA 90S	1.40	0.33	2820	1415	0.0022	71	69	0.85	0.83	3.4	0.8	4.74	2.2	1.8	1.9	4.5	3.9	2	2.1	11.9
CA 90L	1.84	0.37	2825	1415	0.0028	71	72	0.85	0.80	4.4	0.9	6.22	2.5	1.9	2.2	4.6	4.8	2.1	2.3	14.2
CA 90L	2	0.50	2830	1415	0.0032	72	73	0.84	0.82	4.8	1.2	6.75	3.4	2	2.1	4.6	4.5	2.2	2.4	15
CA 100L	2.5	0.65	2830	1400	0.0057	70	70	0.86	0.87	6	1.5	8.44	4.4	1.8	1.6	4.6	3.5	2	1.8	20
CA 100L	3.1	0.80	2845	1405	0.0071	73	70	0.86	0.89	7.1	1.9	10.4	5.4	2	1.8	5.2	4.7	2.2	2	22.4
CA 112MT	4.4	1.1	2860	1415	0.0092	79	71	0.85	0.87	9.5	2.6	14.7	7.4	2	1.8	5.5	4.9	2.2	2	27
CA 132S	5.9	1.45	2870	1435	0.0207	82	80	0.84	0.85	12.4	3.1	19.6	9.7	2	1.8	5.5	5.4	2.2	2	43
CA 132M	8	2	2875	1445	0.0282	84	82	0.84	0.85	16.4	4.1	26.6	13.2	2	1.8	6.2	6	2.2	2	50.3
CA 160MT	11.5	2.9	2875	1445	0.0395	86	85	0.85	0.86	23	5.7	38.2	19.2	2	1.8	7	6.9	2.2	2	69.5
CA 160L	15.5	3.8	2915	1460	0.0800	87	87	0.87	0.90	30	7.0	50.8	24.9	2.3	2.2	6.5	6.1	2.4	2.3	89
CA 180MT	18.5	4.0	2930	1465	0.0978	87	88	0.87	0.88	35	7.5	60.3	26.1	2.5	2.8	7.3	7.9	2.7	2.9	110
CA 180LT	22	4.4	2940	1470	0.124	87	88	0.87	0.88	42	8.2	71.5	28.6	2.6	2.9	7.5	8	2.8	3	128
CA 200LT	30	5.9	2940	1470	0.180	88	88	0.89	0.90	55	10.8	97.5	38.3	2.2	2.5	7.9	8.4	2.4	2.6	170
CA 225ST	37	7.5	2945	1475	0.345	88	87	0.89	0.90	68	13.8	120	48.6	2.3	2.4	8.3	8.3	2.5	2.6	220
CA 225MT	44	8.8	2945	1475	0.419	88	87	0.89	0.90	81	16.2	143	57	2.3	2.4	8.3	8.5	2.5	2.6	250
CA 250MT	55	11	2950	1480	0.541	89	89	0.90	0.89	99	20	178	71	2.3	2.6	8.3	8.7	2.5	2.8	340
CA 280ST	66	15	2960	1485	1.23	90	91	0.90	0.90	118	26	213	96.5	2.3	2.5	8.4	8.7	2.5	2.7	415
CA 280MT	85	18.4	2960	1485	1.39	90	91	0.90	0.90	152	32	274	118	2.2	2.4	8.2	8.5	2.4	2.6	470
CA 315M	96	22	2975	1485	2.68	90	91	0.88	0.84	175	42	308	142	2.4	2.7	8	8.1	2.5	2.8	590
CA 315M	110	26	2978	1487	2.58	90	91	0.88	0.84	201	49	353	167	2.5	2.8	8	8.1	2.6	2.9	720

Dati tecnici

Per ventilatori

Servizio S1 - 400 V - 50 Hz

A due polarità - avvolgimento unico - DAHLANDER

4-8 poli - 1.500-750 giri/min

Technical data

For fans

S1 Duty - 400 V - 50 Hz

Double polarity - single winding - DAHLANDER

4-8 poles - 1.500-750 rpm

Tipo Type	Potenza Power		Velocità Speed		J	Rendimento Efficiency		Fattore di potenza Power factor		Corrente Current In (400 V)		Coppia nom. Nom. torque		Coppia di spunto Starting torque		Corrente di spunto Starting current		Coppia massima Max torque		Forma B3 Mount B3 Peso Weight
	kW		giri/min rpm			kgm ²	%		cosφ		A		Nm		Ca/Cn Tst/Tn		Ia/In Ist/In		Cmax/Cn Tmax/Tn	
	4p	8p	4p	8p	4p		8p	4p	8p	4p	8p	4p	8p	4p	8p	4p	8p	4p	8p	
Serie CA (carcasa in alluminio) - CA Series (aluminium frame)																				
CA 71	0.18	0.037	1385	685	0.00105	54	37	0.78	0.59	0.62	0.24	1.24	0.52	1.7	1.5	2.9	2.9	1.8	1.6	5.8
CA 71	0.22	0.044	1390	690	0.00129	55	38	0.78	0.60	0.74	0.28	1.51	0.61	1.8	1.6	3	3	1.9	1.7	6.5
CA 71	0.26	0.051	1390	690	0.00157	56	40	0.78	0.60	0.86	0.31	1.79	0.71	1.8	1.6	3	3	1.9	1.7	7.4
CA 80	0.5	0.1	1395	695	0.00256	66	55	0.78	0.62	1	0.42	3.42	1.37	1.6	1.9	3.9	3.9	1.9	2	9.8
CA 80	0.7	0.15	1395	695	0.00329	67	62	0.80	0.63	1.9	0.55	4.79	2.06	1.6	1.8	4.1	4.1	1.9	2	11.4
CA 90S	1.1	0.22	1410	690	0.0022	68	46	0.7	0.45	3.34	1.5	7.45	3.04	1.8	2.1	4.5	4.5	2.2	2.3	11.9
CA 90L	1.5	0.25	1410	690	0.0028	70	50	0.75	0.45	4.13	1.6	10.2	4.46	2	2.3	4.8	4.8	2.5	2.6	14.2
CA 100L	2.2	0.37	1410	695	0.0064	76	54	0.8	0.58	5.23	1.7	14.9	5.08	2	2	5.2	5.2	2.4	2.2	21.2
CA 100L	3	0.55	1415	695	0.0086	79	58	0.79	0.55	6.95	2.5	20.2	7.56	2.2	2	5.5	5.5	2.5	2.3	23.5
CA 112M	4.0	0.75	1430	700	0.0147	82	65	0.80	0.62	8.8	2.7	26.7	10.2	2.3	2	5.5	5.5	2.5	2.3	34
CA 132S	5.5	1.4	1430	700	0.0244	82	66	0.81	0.65	12.0	4.7	36.7	19.1	2.3	2	6	6	2.6	2.3	46.8
CA 132M	6.5	1.5	1430	705	0.028	84	67	0.81	0.63	13.8	5.1	43.4	21.7	2.4	2	6.4	6.4	2.7	2.4	50.3
CA 132M	7.5	1.8	1440	705	0.034	84	71	0.81	0.60	15.9	6.1	49.8	24.4	2.4	2	6.6	6.6	3	2.4	55.8
CA 160MT	9	2.2	1450	705	0.034	85	72	0.82	0.61	19	7.2	59.3	29.8	2.4	2.1	6.6	6.6	2.7	2.4	69.5
CA 160M	11	2.8	1460	715	0.039	85	72	0.82	0.70	22.8	8.0	72	37.4	2.4	1.7	6	6	2.3	1.7	71
CA 160L	13	3	1460	715	0.058	87	75	0.82	0.70	26.3	8.3	85.1	40.1	2.5	1.7	6	6	2.3	1.7	89
CA 160L	15	3.5	1460	720	0.058	88	77	0.86	0.71	28.6	9.3	98.1	50.4	2.5	1.7	6	6	2.3	1.7	110
CA 180MT	18.5	4.8	1460	720	0.080	88	79	0.86	0.71	35	12.4	121	59.7	2.5	1.7	6	6	2.3	1.7	119
CA 180L	22	5.3	1460	720	0.098	88	79	0.86	0.71	42	13.7	144	73	2	1.7	6	6	2.4	1.8	155
CA 200LT	30	7	1465	720	0.098	89	86	0.82	0.68	59	17.3	196	99.5	2.5	2	6.8	6.8	2.7	2.1	179
CA 225ST	37	9	1465	725	0.116	89	82	0.87	0.70	69	23	241	119	2.5	2	6.8	6.8	2.8	2	216
CA 225MT	45	11	1465	725	0.161	89	82	0.87	0.70	84	28	293	145	2.5	2	6.8	6.8	2.8	2	235
CA 250MT	50	12	1470	730	0.206	90	82	0.89	0.73	90	29	325	157	2.5	1.9	7.2	7.2	2.8	2	308
CA 250MT	56	14	1470	730	0.345	90	83	0.89	0.80	101	30.5	364	183	2.4	1.9	7.2	7.2	2.8	2	308
CA 280ST	60	15	1480	730	0.34	91	86	0.87	0.73	110	35	390	196	2.5	1.9	7	7	2.4	1.8	330
CA 280MT	75	19	1480	735	0.39	92	87	0.87	0.73	135	42.1	484	242	2.5	2	7	7	2.5	1.8	415
CA 315ST	90	22	1480	735	0.58	92	87	0.86	0.73	164	50.1	581	286	2.5	2	7.1	7.1	2.6	1.9	496
CA 315M	110	28	1485	740	0.58	92	87	0.87	0.73	199	63.7	710	364	2.6	2.1	7.4	7.4	3	2	628
CA 315M	132	33	1485	740	0.58	92	90	0.86	0.72	241	73.6	852	429	2.5	2	7.5	7.5	2	1.9	700

Dati tecnici

Per ventilatori

Servizio S1 - 400 V - 50 Hz

A due polarità - due avvolgimenti separati

4-6 poli - 1.500-1.000 giri/min

Technical data

For fans

S1 Duty - 400 V - 50 Hz

Double polarity - two separate windings

4-6 poles - 1.500-1.000 rpm

Tipo Type	Potenza Power		Velocità Speed		J	Rendimento Efficiency		Fattore di potenza Power factor		Corrente Current In (400 V)		Coppia nom. Nom. torque		Coppia di spunto Starting torque		Corrente di spunto Starting current		Coppia massima Max torque		Forma B3 Mount B3 Peso Weight
	kW		giri/min rpm		kgm ²	%		cosφ		A		Nm		Ca/Cn Tst/Tn		Ia/In Ist/In		Cmax/Cn Tmax/Tn		kg
	4p	6p	4p	6p		4p	6p	4p	6p	4p	6p	4p	6p	4p	6p	4p	6p	4p	6p	
Serie CA (carcassa in alluminio) - CA Series (aluminium frame)																				
CA 71	0.18	0.05	1410	950	0.00039	50	35	0.65	0.55	0.80	0.38	1.22	0.51	1.3	1.5	2.4	1.9	1.5	1.6	5.8
CA 71	0.26	0.075	1415	960	0.00129	50	35	0.70	0.60	1.07	0.52	1.76	0.75	1.3	1.5	2.4	1.9	1.5	1.6	6.5
CA 80	0.40	0.12	1405	940	0.00164	63	55	0.71	0.69	1.29	0.46	2.72	1.22	1.4	1.4	3	2.5	1.6	1.5	7.4
CA 80	0.55	0.18	1420	950	0.00256	63	57	0.72	0.69	1.75	0.66	3.7	1.81	1.6	1.5	3.4	3	1.8	1.6	9.8
CA 90S	0.8	0.29	1425	955	0.00354	73	60	0.74	0.70	2.14	1	5.36	2.9	1.7	1.4	4.4	3.1	2	1.5	13.5
CA 90L	1.1	0.38	1425	955	0.00505	73	60	0.77	0.70	2.8	1.31	7.37	3.8	1.7	1.4	4.4	3.1	2	1.5	15.5
CA 100L	1.7	0.6	1425	950	0.0087	73	61	0.85	0.77	4.0	1.85	11.4	6.03	1.4	1.3	4.4	3.4	1.9	1.8	19.6
CA 100L	2.1	0.75	1430	955	0.012	75	61	0.84	0.77	4.85	2.3	14	7.5	1.5	1.3	5.3	3.5	2	1.8	23.5
CA 112MT	2.6	0.8	1430	955	0.014	75	63	0.85	0.77	5.9	2.4	17.4	8	1.6	1.4	5.5	3.6	2	1.8	26
CA 112M	3	0.9	1445	960	0.015	78	70	0.80	0.70	6.9	2.7	19.8	8.96	1.9	1.5	5.7	4.7	2.2	1.9	37
CA 132S	3.6	1.2	1450	965	0.031	82	74	0.82	0.75	7.7	3.1	23.7	11.9	1.9	1.5	6.7	5.1	2.4	2.3	45.5
CA 132M	5.5	1.7	1450	965	0.041	83	74	0.82	0.76	10.6	4.4	32.9	16.8	2	1.6	7	5.1	2.7	2.5	52.5
CA 160MT	7.2	2.5	1450	965	0.054	84	77	0.83	0.76	14.9	6.2	47.4	24.7	1.9	1.5	7	5.4	2.7	2.5	69
CA 160L	10	3.3	1450	980	0.109	85	80	0.87	0.70	19.5	8.5	65.9	32.2	1.6	1.5	6	5.5	2.2	1.9	82
CA 180MT	16	5.5	1450	982	0.129	87	82	0.88	0.72	30	13.5	105	53.5	1.7	1.6	6	5.8	2.4	2	114
CA 180LT	19	6.5	1450	985	0.174	87	82	0.85	0.71	37	16.1	125	63	2.1	1.9	7.2	6.6	2.7	2.5	130
CA 200LT	26	9.5	1472	985	0.193	88	84	0.85	0.78	50	21	169	92.1	1.9	1.8	7	5.7	2.3	1.9	180
CA 225ST	34	12	1480	985	0.370	89	85	0.86	0.79	64	25.8	219	116	2.3	2	7.4	5.5	2.8	2.4	235
CA 225MT	40	14.5	1480	985	0.419	90	86	0.87	0.80	74	30.5	258	141	2.4	2	7.9	6	2.9	2.5	260
CA 250MT	52	18	1480	985	0.613	90	86	0.90	0.80	93	38	336	175	2.2	1.9	7.9	6.2	2.7	2.2	360
CA 280ST	70	25	1480	987	1.39	91	89	0.90	0.83	124	49	452	242	2.6	2.4	7.3	6.5	2.8	2.5	470
CA 280MT	82	30	1485	987	1.55	91	89	0.90	0.84	145	58	527	290	2.7	2.4	7.5	6.5	2.9	2.5	496
CA 315M	92	28	1485	990	3.09	91	90	0.85	0.74	172	61	592	270	2.4	2.5	7	6.9	2.6	2.6	670
CA 315M	110	33	1488	993	3.91	91	90	0.85	0.74	206	72	706	317	2.7	2.5	7.5	6.8	2.9	2.6	760
CA 315M	125	37	1488	993	4.32	92	90	0.86	0.74	228	80	802	356	2.1	2.3	6.7	6	2.4	2.5	830
CA 315M	162	48	1489	994	5.76	92.5	90.5	0.85	0.74	298	104	1039	461	2.7	2.5	7.5	6.8	2.9	2.6	1020

Dati tecnici

Per ventilatori

Servizio S1 - 400 V - 50 Hz

A due polarità - due avvolgimenti separati

6-8 poli - 1.000-750 giri/min

Technical data

For fans

S1 Duty - 400 V - 50 Hz

Double polarity - two separate windings

6-8 poles - 1.000-750 rpm

Tipo Type	Potenza Power		Velocità Speed		J	Rendimento Efficiency		Fattore di potenza Power factor		Corrente Current In (400 V)		Coppia nom. Nom. torque		Coppia di spunto Starting torque		Corrente di spunto Starting current		Coppia massima Max torque		Forma B3 Mount B3 Peso Weight
	kW		giri/min rpm			kgm ²	%		cosφ		A		Nm		Ca/Cn Tst/Tn		Ia/In Ist/In		Cmax/Cn Tmax/Tn	
	6p	8p	6p	8p	6p		8p	6p	8p	6p	8p	6p	8p	6p	8p	6p	8p	6p	8p	
Serie CA (carcassa in alluminio) - CA Series (aluminium frame)																				
CA 71	0.088	0.037	920	640	0.00105	35	24	0.60	0.55	0,61	0.4	0.91	0.55	1.3	1.2	1.9	1.5	1.5	1.4	5.8
CA 71	0.11	0.048	920	650	0.00129	39	25	0.61	0.55	0,67	0.5	1.14	0.71	1.3	1.2	1.9	1.5	1.5	1.4	6.5
CA 71	0.15	0.062	920	650	0.00157	44	27	0.65	0.55	0,76	0.6	1.56	0.91	1.3	1.2	2	1.5	1.5	1.4	7.4
CA 80	0.18	0.075	925	690	0.00164	52	42	0.65	0.55	0,77	0.47	1.86	1.04	1.3	1.2	2.4	2.1	1.5	1.4	7.6
CA 80	0.30	0.12	925	690	0.00256	55	45	0.68	0.59	1,16	0.65	3.1	1.66	1.4	1.3	2.6	2.3	1.6	1.6	9.8
CA 90S	0.37	0.16	930	690	0.00303	63	52	0.72	0.67	1,18	0.66	3.8	2.21	1.4	1.3	3	2.2	1.8	1.6	10.8
CA 90L	0.55	0.23	930	690	0.00455	64	54	0.73	0.70	1,70	0.88	5.65	3.18	1.5	1.4	3.1	2.3	1.9	1.7	13.5
CA 90L	0.75	0.32	930	700	0.00606	64	54	0.73	0.70	2,32	1.22	7.7	4.37	1.5	1.4	3.3	2.5	1.9	1.7	16.5
CA 100L	0.88	0.37	935	705	0.00870	66	59	0.74	0.70	2,60	1.3	9.0	5.0	1.5	1.4	3.6	2.9	1.9	1.7	19.6
CA 100L	1.1	0.48	940	705	0.0120	67	60	0.76	0.72	3,12	1.6	11.2	6.5	1.5	1.4	3.8	3	1.9	1.8	23.5
CA 112MT	1.5	0.62	940	705	0.0141	70	62	0.76	0.72	4,1	2	15.2	8.4	1.6	1.5	4	3.2	2	1.9	26
CA 112M	1.9	0.80	945	710	0.0147	78	66	0.76	0.72	4,6	2.4	19.2	10.8	1.5	1.4	4.1	3.1	2.1	1.9	37
CA 132S	1.84	0.75	945	705	0.023	78	67	0.76	0.72	4,5	2.2	18.6	10.2	1.6	1.5	4.5	3.7	2.1	1.9	39
CA 132S	2.5	1.1	950	710	0.031	79	69	0.77	0.73	5,9	3.2	25.1	14.8	1.6	1.5	4.9	3.8	2.3	2	45.5
CA 132M	3.3	1.5	950	715	0.046	79	71	0.77	0.73	7,8	4.2	33.2	20	1.6	1.5	5.4	4.4	2.3	2.2	56
CA 160MT	4.4	1.9	950	715	0.054	79	72	0.78	0.73	10,3	5.2	44.2	25.4	1.6	1.5	5.4	4.5	2.3	2.2	69
CA 160M	5.5	2.35	955	720	0.077	82	78	0.82	0.73	11,8	6.0	55	31.2	1.6	1.7	5.4	5.3	2.3	2.4	71
CA 160L	7.5	3.3	960	720	0.109	83	80	0.84	0.74	15,5	8.1	74.6	43.8	1.6	1.7	5.4	5.3	2.3	2.4	88
CA 180MT	8.8	3.9	960	725	0.129	83	80	0.85	0.74	18	9.5	87.6	51.4	1.7	1.8	5.6	5.5	2.4	2.5	105
CA 180LT	11	4.8	960	725	0.154	83	80	0.85	0.75	22,5	11.6	109	63.2	1.7	1.8	5.9	5.8	2.4	2.5	117
CA 200LT	15	6.2	980	730	0.22	84	80	0.84	0.75	31	14.9	146	81.1	1.9	1.8	6.4	5.8	2.4	2.3	175
CA 200LT	18.4	7.5	980	735	0.30	85	80	0.84	0.75	37	18	179	97.5	1.9	1.8	6.8	5.8	2.5	2.3	212
CA 225MT	22	9.5	980	735	0.61	87	83	0.85	0.75	43	22	214	123	1.9	2	6.5	6.5	2.4	2.5	260
CA 250MT	26	11	985	735	0.90	87	83	0.84	0.73	51	26	252	143	2.1	2.3	6.3	5.8	2.5	2.5	317
CA 250MT	30	12.5	985	735	1.02	88	84	0.85	0.74	58	29	291	162	2.1	2.3	6.3	6.1	2.7	2.8	360
CA 280ST	33	14	985	738	1.75	89	86	0.85	0.78	63	30	320	181	2.2	2.2	5.8	5.5	2.6	2.4	430
CA 280MT	40	17	985	738	2.00	89	86	0.86	0.79	76	36	388	220	2.3	1.9	6	5.4	2.7	2	460
CA 315ST	48	20	985	738	2.43	90	86	0.86	0.79	90	43	465	259	2.4	2	6	5.6	2.8	2.2	528
CA 315M	55	23.5	988	740	3.23	91	90	0.86	0.78	102	48	532	303	2.2	2.1	6	5.8	2	1.8	600
CA 315M	65	28	990	740	3.62	92	91	0.86	0.79	119	56	627	361	2.2	2	6	5.5	2	1.7	645

Alimentazione da inverter

I motori asincroni trifase serie C sono previsti anche per alimentazione da inverter e sono progettati e costruiti operando delle scelte progettuali e costruttive che consentono un funzionamento ottimale ed affidabile.

Particolare attenzione richiede pertanto il sistema d'isolamento ed impregnazione del motore che deve essere in grado di sopportare le maggiori sollecitazioni derivanti da questo tipo di alimentazione.

I motori previsti per alimentazione a 690 V sono realizzati con un sistema di isolamento rinforzato (sistema HPI).

Secondo la specifica tecnica "IEC TS 60034-25", i motori per inverter sono idonei a lavorare nelle seguenti condizioni:

Tensione di alimentazione ≤ 500 V - Curva A

Tensione di picco 1,56 kV

Tensione di alimentazione > 500 V e ≤ 690 V - Curva B

Tensione di picco 2,15 kV

Rise time $\geq 0,4$ μ sec

Nel caso di valori più elevati è consigliabile l'impiego di un adeguato filtro tra motore ed inverter per ridurre le sollecitazioni sul motore.

Analogamente è necessario un filtro nel caso di eccessiva lunghezza dei cavi di alimentazione (distanza tra motore e inverter maggiore di 50 metri).

I motori normali sono previsti con sistema di ventilazione IC 411 (autoventilato) e sono idonei per applicazioni su macchine operatrici a coppia quadratica (pompe o ventilatori) e per funzionamento a coppia costante con frequenza di alimentazione minima di 30 Hz.

A richiesta possono essere forniti motori con sistema di ventilazione IC 416 (servo-ventilato) per applicazioni a coppia costante con frequenza minima di 5 Hz.

È necessario l'utilizzo di cavi e collegamenti conformi alle raccomandazioni EMC (compatibilità elettromagnetica).

Il motore e il sistema motore devono essere adeguatamente messi a terra, per evitare possibili tensioni e correnti nei cuscinetti del motore.

Inoltre, devono essere seguite le istruzioni aggiuntive fornite dal produttore di inverter.

La velocità massima che i motori possono raggiungere è limitata dalle sollecitazioni meccaniche che possono sopportare senza danneggiamenti. Nella tabella dei dati tecnici nelle pagine seguenti è riportato tale limite per il funzionamento in servizio continuativo.

Per brevi periodi è possibile superare tale limite di circa il 10% senza che si verifichino danneggiamenti dei cuscinetti.

Nelle tabelle dei dati tecnici, sono riportate oltre alle caratteristiche elettriche, i limiti di velocità quale i motori possono funzionare erogando la potenza nominale con un margine tra la coppia massima e la coppia nominale del 50%. Oltre tale velocità e fino alla velocità massima ammessa i motori possono funzionare a potenza ridotta. Il valore di coppia massima (espresso in Nm) del motore in queste condizioni si ottiene moltiplicando il valore della coppia massima per il rapporto tra velocità nominale e velocità massima al quadrato.

Occorre tener presente che aumentando la velocità di funzionamento aumenta

Inverter supply

C series asynchronous three-phase motors can also be used with inverter supply; they are designed and manufactured based on design and manufacturing choices that allow an optimum and reliable operation.

Consequently the motor insulation and impregnation must be carried out with the utmost care because they have to be able to withstand with the higher stresses caused by such kind of supply.

Motors designed for 690 V supply are manufactured with a reinforced insulation system (HPI system).

According to the Technical Specification "IEC TS 60034-25", motors for inverter are suitable to work under the following conditions:

Supply voltage ≤ 500 V - Curve A

Peak voltage 1,56 kV

Supply voltage > 500 V and ≤ 690 V - Curve B

Peak voltage 2,15 kV

Rise time $\geq 0,4$ μ sec

In case of higher values it is advisable to use a proper filter between motor and inverter to reduce stresses on the motor.

Similarly a filter is necessary in case of too long supply cables (distance between motor and inverter higher than 50 metres).

Standard motors are designed with IC 411 cooling system (self-ventilated) and are suitable for applications on manufacturing machines with quadratic torque (pumps or fans) and for operation with constant torque with minimum supply frequency of 30 Hz.

Upon request, motors with IC 416 cooling system (with forced ventilation) for applications with constant torque with minimum frequency of 5 Hz, can be supplied.

The use of cables and connections conforming to EMC (electro-magnetic compatibility) recommendations is necessary.

The motor and the driven system must be properly earthed, to avoid possible voltages and currents in the bearings of the motor.

The additional instructions given by the inverter manufacturer must also be followed.

The maximum speed that the motors can reach is limited by the mechanical stresses that they can withstand without being damaged. The technical data tables on the following pages give the value of this limit for the continuous duty operation.

It is possible to exceed this limit of approx. 10% for short periods without having damages at the bearings.

In addition to the electric features, technical data tables also contain speed limits at which the motors can operate supplying the rated output with a 50% margin between the maximum torque and the rated torque.

Above this speed and up to the maximum speed permitted, motors can run at reduced power. Value of the maximum torque of the motor (given in Nm) in these conditions is obtained multiplying the value of the maximum torque by the ratio between the rated speed and the maximum speed squared.

It has to be considered that with the increase of the operation speed, also

anche il rumore emesso dal motore stesso, pertanto per aumenti superiori al 20% della velocità nominale si consiglia l'impiego di motori servo-ventilati (IC 416).

Funzionamento a potenza aumentata Motori serie CA grandezze 63÷160

I motori serie CA (fino al 160) in esecuzione standard previsti per alimentazione a 230 V / 50 Hz con collegamento a triangolo, possono essere alimentati a frequenze maggiori di 50 Hz con tensione proporzionale alla frequenza fino a 100 Hz (2 volte la velocità nominale). In tal caso la potenza erogabile in servizio continuo (S1) può essere aumentata secondo quanto indicato nel diagr. 5.

La corrente nel funzionamento a potenza nominale a 50 Hz aumenta di circa 1.73 volte il valore indicato nelle tabelle relativi ai dati tecnici a 400 V; il valore di corrente assorbita alla potenza di 100 Hz varia in modo lineare.

Ovviamente anche in questo caso non devono mai essere superati i limiti di velocità indicati alla tabelle dei dati tecnici.

the noise emitted by the motor itself, therefore for increases higher than 20% of the rated speed it is advisable to use motors with forced ventilation (IC 416).

Increased power operation CA series frame sizes 63÷160

CA series motors (up to size 160) in standard execution designed to be supplied at 230 V / 50 Hz with delta connection, may be supplied at frequencies higher than 50 Hz with voltage proportional to the frequency up to 100 Hz (twice the rated speed). In such case the motor output in continuous duty (S1) may be increased as shown in diagr. 5.

During operation at rated power at 50 Hz, current increases by approx. 1.73 times the value shown in the tables concerning the technical data at 400 V; the value of input current at the power of 100 Hz linearly changes.

Of course also in this case the speed limits shown in the technical data tables must never be exceeded.

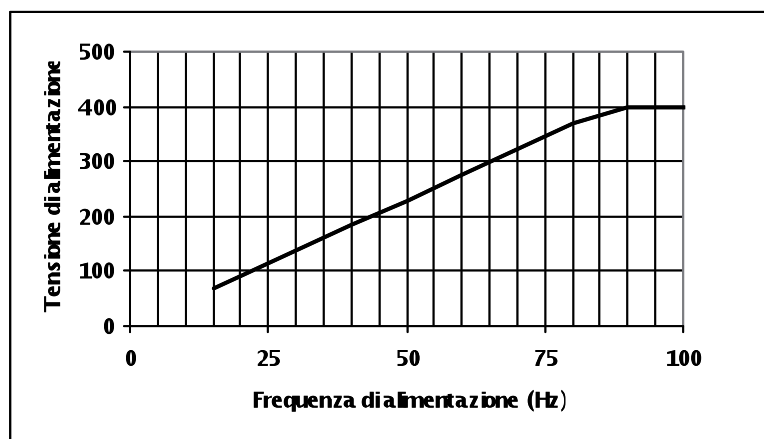

Diag. 4 - Diagramma tensione di alimentazione-frequenza previsto per i motori serie C (230 V / 50 Hz) per il funzionamento a potenza aumentata.
Diag. 4 - Supply voltage - frequency diagram intended for the C series motors (230 V / 50 Hz) for operation at increased power.

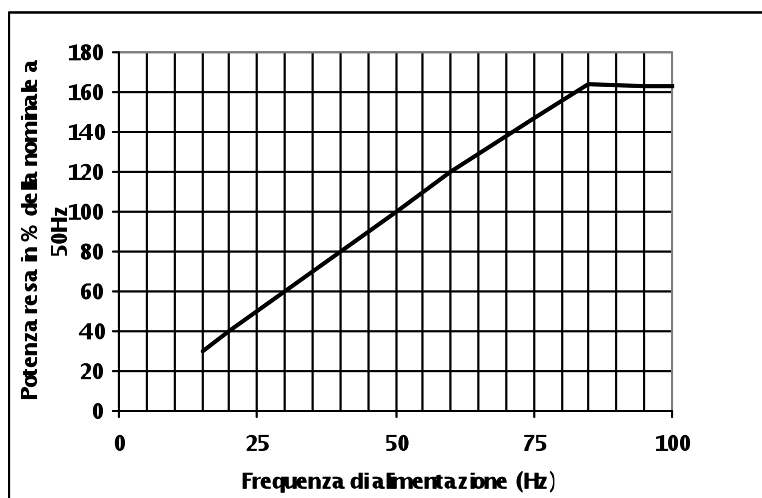

Diag. 5 - Diagramma potenza resa -frequenza per i motori serie CA (220 V / 50 Hz) per il funzionamento a potenza aumentata.
Diag. 5 - Power output - frequency diagram intended for the CA series motors (220 V / 50 Hz) for operation at increased power.

Dati tecnici

ALIMENTAZIONE DA INVERTER

Classe di efficienza IE1 (IEC 60034-30; 2008)

Isolamento classe F - Servizio S1 - 400 V - 50 Hz

2 poli - 3.000 giri/min

Technical data

INVERTER SUPPLY

IE1 Efficiency class (IEC 60034-30; 2008)

Insulation class F - S1 Duty - 400 V - 50 Hz

2 poles - 3.000 rpm

Tipo Type	Potenza Power	Velocità Speed	J	Rend. Eff.	Fattore di potenza Power factor	Corrente Current In/at (400 V)	Coppia nom. Nominal torque	Coppia massima Max torque	Velocità max a potenza costante Max speed constant power	Velocità max Max speed	Rumor. Noise	Forma B3 Mount B3 Peso Weight
	kW	giri/min rpm	kgm ²	%	cosφ	A	Nm	Cmax/Cn Tmax/Tn	giri/min rpm	giri/min rpm	dB (A)	kg
Serie CA (carcassa in alluminio) - CA Series (aluminium frame)												
CA 63-a	0.18	2680	0.0002	64	0.75	0.54	0.641	2.5	4500	6000	57	3.3
CA 63-b	0.25	2700	0.0002	64	0.75	0.75	0.884	2.5	4500	6000	57	3.8
CA 71-a	0.37	2800	0.0004	71	0.8	0.94	1.262	2.3	4000	6000	59	6
CA 71-b	0.55	2810	0.0005	71	0.8	1.4	1.869	2.6	4500	6000	59	7
C1A 80-a	0.75	2820	0.0012	76	0.81	1.8	2.54	2.4	4200	6000	63	8.6
C1A 80-b	1.1	2820	0.0017	76.2	0.81	2.6	3.72	2.4	4200	6000	63	10.2
C1A 90S	1.5	2840	0.0012	78.5	0.8	3.4	5.04	2.5	4300	6000	68	11.5
C1A 90L	2.2	2840	0.0019	81	0.78	5	7.4	2.5	4300	6000	68	13.5
C1A 100L	3	2850	0.0032	82.6	0.81	6.4	10.1	2.8	4700	6000	72	20.5
C1A 112MT-a	4	2860	0.0042	84.2	0.8	8.6	13.4	2.8	4700	6000	72	23
C1A 112MT-b	5.5	2880	0.0055	83.5	0.84	11.3	18.2	2.8	4700	6000	72	28.2
C1A 132S-a	5.5	2900	0.009	85.7	0.85	10.9	18.1	2.8	4700	6000	74	38.4
C1A 132S-b	7.5	2900	0.0113	87	0.85	14.7	24.7	2.8	4700	5000	74	42
C1A 132M	9	2910	0.015	86	0.86	17.6	29.5	2.7	4600	5000	74	47.5
C1A 160MT-a	11	2910	0.017	88.4	0.84	21	36.1	2.7	4600	5000	74	58
C1A 160MT-b	15	2930	0.023	89.4	0.85	29	48.9	2.8	4700	5000	75	68
C1A 160L	18.5	2940	0.043	90	0.85	35	60.1	2.8	4700	5000	75	90
C1A 180MT	22	2950	0.051	90.5	0.85	42	71.2	2.9	4800	5000	75	110
C1A 180LT	25	2950	0.059	89.5	0.86	47	80.9	2.9	4800	5000	75	116
C1A 200LT-a	30	2950	0.089	91.4	0.86	55	97	3	4900	5000	83	142
C1A 200LT-b	37	2960	0.111	92	0.86	68	119	3	4900	5000	83	162
C1A 225MT	45	2960	0.18	92.5	0.86	82	145	3	4800	4800	83	210
C1A 250MT	55	2970	0.283	93	0.87	98	177	3	4500	4500	83	280
C1A 280ST	75	2970	0.493	93.6	0.87	132	241	2.9	4500	4500	84	372
C1A 280MT	90	2970	0.587	93.9	0.88	158	289	3	4500	4500	87	407
C1A 315ST	110	2975	0.751	93.5	0.89	191	353	2.8	4500	4500	87	496
C1A 315M	132	2980	1.27	93.5	0.89	229	423	2.7	3600	3600	90	620
C1A 315M	160	2980	1.52	93.5	0.89	278	513	2.7	3600	3600	90	668
C1A 315M	200	2980	1.83	94	0.9	342	641	2.7	3600	3600	90	760
C1A 355LT	250	2980	2.29	94	0.9	427	801	2.4	3600	3600	90	895

I valori di rendimento sono calcolati in accordo con IEC 60034-2-1 con alimentazione sinusoidale.

Efficiency values are given according to IEC 60034-2-1 with sinusoidal supply.

Dati tecnici

ALIMENTAZIONE DA INVERTER

Classe di efficienza IE1 (IEC 60034-30; 2008)

Isolamento classe F - Servizio S1 - 400 V - 50 Hz

4 poli - 1.500 giri/min

Technical data

INVERTER SUPPLY

IE1 Efficiency class (IEC 60034-30; 2008)

Insulation class F - S1 Duty - 400 V - 50 Hz

4 poles - 1.500 rpm

Tipo Type	Potenza Power	Velocità Speed	J	Rend. Eff.	Fattore di potenza Power factor	Corrente Current In/at (400 V)	Coppia nom. Nominal torque	Coppia massima Max torque	Velocità max a potenza costante Max speed costant power	Velocità max Max speed	Rumor. Noise	Forma B3 Mount B3 Peso Weight
	kW	giri/min rpm	kgm ²	%	cosφ	A	Nm	Cmax/Cn Tmax/Tn	giri/min rpm	giri/min rpm	dB (A)	kg
Serie CA (carcassa in alluminio) - CA Series (aluminium frame)												
CA 63-a	0.13	1340	0.0002	60	0.6	0.5	0.93	2.3	2000	6000	49	3.8
CA 63-b	0.18	1340	0.0003	61	0.6	0.7	1.28	2.3	2000	6000	49	4.1
CA 71-a	0.25	1350	0.0004	68	0.65	0.8	1.77	2	1800	6000	51	5.7
CA 71-b	0.37	1350	0.0005	69	0.67	1.2	2.62	2	1800	6000	51	7
CA 80-a	0.55	1360	0.0012	72	0.7	1.6	3.86	2.3	2000	6000	54	8.6
C1A 80-b	0.75	1360	0.0017	73	0.73	2.0	5.27	2.3	2000	6000	54	10
C1A 90S	1.1	1380	0.0022	76.2	0.78	2.7	7.61	2.5	2200	6000	56	11.9
C1A 90L	1.5	1380	0.0028	78.5	0.77	3.6	10.38	2.5	2200	6000	56	14.2
C1A 100L-a	2.2	1410	0.005	81	0.79	5.0	14.90	2.2	2000	6000	60	18.7
C1A 100L-b	3	1410	0.006	82.6	0.8	6.6	20.32	2.2	2000	6000	60	21.2
C1A 112MT	4	1420	0.009	84.2	0.81	8.5	26.90	2.5	2200	6000	60	25.7
C1A 132S	5.5	1430	0.021	85.7	0.8	11.6	36.7	2.5	2200	6000	63	43
C1A 132M-a	7.5	1430	0.028	87	0.81	15.4	50.1	2.5	2200	5000	63	50.3
C1A 132M-b	9	1430	0.034	87	0.81	18.5	60.1	2.5	2200	5000	63	55.8
C1A 160MT	11	1465	0.039	88.4	0.83	21.7	71.7	2.6	2200	5000	63	69.5
C1A 160L	15	1465	0.08	89.4	0.82	29.6	97.8	2.6	2200	6500	67	89
C1A 180MT	18.5	1470	0.098	90	0.83	35.8	120	2.8	2400	6300	67	110
C1A 180LT	22	1470	0.12	90.5	0.83	42.3	143	2.8	2400	6300	67	119
C1A 200LT	30	1470	0.16	91.4	0.85	69	195	2.8	2400	5000	70	155
C1A 225ST	37	1480	0.31	92	0.84	84	239	2.9	2400	5000	70	202
C1A 225MT-a	45	1480	0.39	92.5	0.84	100	290	2.9	2400	4500	70	235
C1A 250MT-b	55	1480	0.51	93	0.85	134	355	2.6	2400	4500	70	286
C1A 280ST	75	1485	1.15	93.6	0.86	160	482	2.7	2400	4500	73	387
C1A 280MT	90	1485	1.31	93.9	0.86	193	579	2.7	2400	4500	73	415
C1A 315ST	110	1485	1.55	94	0.88	192	707	2.7	2400	4500	75	496
C1A 315M-a	132	1485	2.6	94	0.88	231	849	2.7	2400	3000	77	630
C1A 315M-b	160	1485	3.5	94	0.88	280	1029	2.7	2400	3000	77	740
C1A 315M-c	200	1485	4.16	94.2	0.89	345	1286	2.8	2400	3000	77	882
C1A 355LT	250	1487	5	94.4	0.89	430	1605	2.3	2100	3000	77	1045

I valori di rendimento sono calcolati in accordo con IEC 60034-2-1 con alimentazione sinusoidale.

Efficiency values are given according to IEC 60034-2-1 with sinusoidal supply.

Dati tecnici

ALIMENTAZIONE DA INVERTER

Classe di efficienza IE1 (IEC 60034-30; 2008)

Isolamento classe F - Servizio S1 - 400 V - 50 Hz

6 poli - 1.000 giri/min

Technical data

INVERTER SUPPLY

IE1 Efficiency class (IEC 60034-30; 2008)

Insulation class F - S1 Duty - 400 V - 50 Hz

6 poles - 1.000 rpm

Tipo Type	Potenza Power	Velocità Speed	J	Rend. Eff.	Fattore di potenza Power factor	Corrente Current In/at (400 V)	Coppia nom. Nominal torque	Coppia massima Max torque	Velocità max a potenza costante Max speed constant power	Velocità max Max speed	Rumor. Noise	Forma B3 Mount B3 Peso Weight
	kW	giri/min rpm	kgm ²	%	cosφ	A	Nm	Cmax/Cn Tmax/Tn	giri/min rpm	giri/min rpm	dB (A)	kg
Serie CA (carcassa in alluminio) - CA Series (aluminium frame)												
CA 63-a	0.09	880	0.0003	43	0.6	0.5	0.98	1.9	1300	6000	48	5
CA 63-b	0.11	890	0.0004	45	0.6	0.6	1.18	1.9	1300	6000	48	5.2
CA 71-a	0.18	890	0.0011	54	0.61	0.8	1.93	1.9	1300	6000	49	5.8
CA 71-b	0.22	890	0.0013	55	0.61	0.9	2.36	2	1400	6000	49	6.5
CA 80-a	0.37	900	0.0016	66	0.71	1.1	3.93	2	1400	6000	51	7.4
CA 80-b	0.55	900	0.0026	69	0.71	1.6	5.84	2.2	1400	6000	51	9.8
C1A 90S	0.75	910	0.0035	72	0.72	2.1	7.87	2.1	1400	6000	54	10.8
C1A 90L	1.1	910	0.0051	73	0.72	3.0	11.54	2	1400	6000	54	13.5
C1A 100L	1.5	920	0.0087	75	0.73	4.0	15.6	2.3	1500	6000	57	19.6
C1A 112MT	2.2	940	0.014	78	0.75	5.4	22.3	2.5	1500	6000	57	25
C1A 132S	3	950	0.023	80	0.78	6.9	30.2	2.3	1500	6000	60	39
C1A 132M-a	4	950	0.031	82	0.78	9.0	40.2	2.6	1500	6000	60	45.5
C1A 132M-b	5.5	950	0.041	83	0.78	12.3	55.3	2.6	1500	6000	60	52.5
C1A 160MT	7.5	960	0.054	85	0.8	15.9	74.6	2.6	1500	6000	60	69
C1A 160L	11	960	0.109	86	0.81	22.8	109.4	2.9	1600	5000	63	88
C1A 180LT	15	970	0.141	87	0.82	30.4	147.7	3	1600	5000	63	114
C1A 200LT-a	18.5	975	0.271	88	0.83	36.6	181.2	2.8	1600	5000	68	145
C1A 200LT-b	22	975	0.32	88	0.83	43.5	215	2.8	1600	4500	68	155
C1A 225MT	30	980	0.541	90	0.84	57.3	292	2.6	1700	4500	72	234
C1A 250MT	37	980	0.752	91	0.84	69.9	361	2.7	1700	3800	73	295
C1A 280ST	45	985	1.37	92	0.82	87	436	2.4	1600	3000	75	381
C1A 280MT	55	985	1.68	92	0.82	105	533	2.4	1600	3000	75	421
C1A 315ST	75	985	2.37	92.5	0.83	141	727	2.3	1500	3000	75	526
C1A 315M-a	90	988	2.7	93	0.83	168.5	870	2.6	1600	2800	84	642
C1A 315M-b	110	986	2.7	93	0.84	203.5	1065	2.6	1600	2800	84	672
C1A 315M-c	132	986	3.15	93.3	0.84	243.4	1278	2.6	1600	2800	84	730
C1A 315M-d	160	987	4.7	94	0.84	292.8	1548	2.6	1600	2800	84	910
C1A 355LT	200	987	5.7	94	0.84	366.0	1935	2.6	1600	2800	84	1144

I valori di rendimento sono calcolati in accordo con IEC 60034-2-1 con alimentazione sinusoidale.

Efficiency values are given according to IEC 60034-2-1 with sinusoidal supply.

Dati tecnici

ALIMENTAZIONE DA INVERTER

Isolamento classe F - Servizio S1 - 400 V - 50 Hz
8 poli - 750 giri/min

Technical data

INVERTER SUPPLY

Insulation class F - S1 Duty - 400 V - 50 Hz
8 poles - 750 rpm

Tipo Type	Potenza Power	Velocità Speed	J	Rend. Eff.	Fattore di potenza Power factor	Corrente Current In (400 V)	Coppia nom. Nominal torque	Coppia massima Max torque	Velocità max a potenza costante Max speed constant power	Velocità max Max speed	Rumor. Noise	Forma B3 Mount B3 Peso Weight
	kW	giri/min rpm	kgm ²	%	cosφ	A	Nm	Cmax/Cn Tmax/Tn	giri/min rpm	giri/min rpm	dB (A)	kg
Serie CA (carcasa in alluminio) - CA Series (aluminium frame)												
CA 63	0.05	640	0.00029	40	0.53	0.34	0.75	1.6	700	6000	48	5
CA 63	0.07	640	0.00039	44	0.54	0.43	1.04	1.6	700	6000	48	5
CA 71	0.11	650	0.0011	44	0.56	0.65	1.6	1.6	700	6000	49	6
CA 71	0.15	650	0.0013	46	0.57	0.83	2.2	1.6	700	6000	49	6.5
CA 80	0.18	670	0.0016	52	0.6	0.83	2.6	2	900	6000	51	7.3
CA 80	0.25	670	0.0026	61	0.6	1	3.6	2	900	6000	51	9.7
CA 90S	0.37	680	0.003	64	0.63	1.3	5.2	2	900	6000	53	10.6
CA 90L	0.55	690	0.0045	67	0.63	1.9	7.6	2	900	6000	53	13.3
CA 100L	0.75	690	0.0087	68	0.64	2.5	10.4	2.1	950	6000	55	19.3
CA 100L	1.1	690	0.0109	70	0.64	3.5	15.2	2.1	950	6000	55	21.5
CA 112MT	1.5	700	0.0141	73	0.65	4.6	20.5	2.4	1100	6000	55	25
CA 132S	2.2	705	0.0307	78	0.71	5.7	29.8	2.2	1000	6000	58	45
CA 132M	3	710	0.0409	79	0.72	7.6	40.4	2.3	1000	6000	58	52
CA 160MT	4	710	0.0537	80	0.73	9.9	53.8	2.1	950	6000	58	68.5
CA 160M	5.5	715	0.0772	82	0.73	13	73	2.1	950	5000	61	70
CA 160L	7.5	720	0.109	84	0.74	17	100	2.2	1000	5000	61	87.5
CA 180LT	11	730	0.154	86	0.76	24	144	2	900	5000	61	117
CA 200LT	15	730	0.345	87	0.76	33	196	2.3	1100	4500	66	155
CA 225ST	18.5	730	0.505	88	0.79	38	242	2.3	1100	4500	70	207
CA 225MT	22	730	0.577	89	0.79	45	288	2.4	1100	4500	70	243
CA 250MT	30	735	0.902	90	0.8	60	390	2.6	1200	3800	71	317
CA 280ST	37	735	1.75	90.5	0.8	74	481	2.3	1100	3000	72	420
CA 280MT	45	735	2.12	91	0.8	89	585	2.3	1100	3000	72	460
CA 315ST	55	740	2.43	92	0.8	108	710	2.2	1100	3000	81	525
CA 315M	75	740	3.1	93	0.8	146	968	2.2	1400	2600	81	671
CA 315M	90	740	3.52	93.5	0.8	174	1162	2.3	1400	2600	81	769
CA 315M	110	740	4.4	93.8	0.8	212	1420	2.3	1400	2600	81	890
CA 315M	132	740	5.1	94	0.8	254	1704	2.4	1400	2600	81	1035
Serie CS (carcasa in acciaio) - CS Series (steel frame)												
CS 355L-a	160	740	8.7	94.3	0.81	303	2065	3.4	1500	2600	79	1300
CS 355L-b	200	742	10.5	94.5	0.82	373	2575	3.4	1500	2600	79	1620
CS 355L-c	250	745	12.6	94.5	0.82	466	3205	3.4	1500	2600	79	1968
CS 355Lx-a	315	745	26.6	95	0.80	600	4039	3	1500	2400	79	2520
CS 355Lx-b	355	745	31.3	95	0.81	667	4550	3	1500	2400	81	2840
CS 400Lx-b	400	745	47.2	95.6	0.86	703	5127	3.2	1400	2200	81	3440
CS 400Lx-c	450	745	54.0	95.6	0.86	791	5768	3.4	1400	2200	83	3600
CS 450Lx-a	500	745	81.4	95.6	0.87	869	6409	3.2	1400	1900	83	4140
CS 450Lx-b	560	745	93.0	95.8	0.87	971	7178	3.4	1400	1900	83	4590
CS 500Lx-a	630	745	108.9	96	0.87	1090	8075	3.4	1300	1800	83	5050
CS 500Lx-b	710	745	120.6	96.2	0.87	1226	9100	3.4	1300	1800	83	5440
CS 500Lx-c	800	745	137.4	96.3	0.87	1380	10254	3.4	1300	1800	79	5980

La classificazione dell'efficienza riguarda solo i motori a 2, 4, e 6 poli.

Efficiency classification concerns only 2, 4 and 6 pole motors.

Dati tecnici

ALIMENTAZIONE DA INVERTER

Classe di efficienza IE2 (IEC 60034-30; 2008)

Alta efficienza

Isolamento classe F - Sovratemperatura classe B

Servizio S1 - 400 V - 50 Hz

2 poli - 3.000 giri/min

Technical data

INVERTER SUPPLY

IE2 Efficiency class (IEC 60034-30; 2008)

High Efficiency

Insulation class F - Temperature rise B

S1 Duty - 400 V - 50 Hz

2 poles - 3.000 rpm

Tipo Type	Potenza Power	Velocità Speed	J kgm ²	Rendimento Efficiency			Fattore di potenza Power factor cosφ			Corrente Current In (400 V)	Coppia nom. Nom. torque	Coppia Massima Max torque	Velocità max a potenza costante Max speed constant power	Velocità massima Max speed	Rumor. Noise	Forma B3 Mount B3 Peso Weight
	kW	giri/min rpm		100%	75%	50%	100%	75%	50%	A	Nm	Cmax/Cn Tmax/Tn	giri/min rpm	giri/min rpm	dB (A)	kg
Serie C2A (carcassa in alluminio) - C2A Series (aluminium frame)																
C2A 80-a	0.75	2870	0.0015	77.4	79	76.6	0.8	0.71	0.54	1.8	2.495	2.4	4500	6000	61	9.6
C2A 80-b	1.1	2975	0.0020	79.6	80.2	77.2	0.8	0.72	0.57	2.5	3.531	2.7	4500	6000	61	11.2
C2A 90S	1.5	2830	0.0016	81.3	80.6	79.9	0.82	0.78	0.67	3.3	5.061	2.6	4400	6000	65	13.9
C2A 90L	2.2	2880	0.0023	83.2	83.6	83.1	0.82	0.78	0.67	4.7	7.294	2.6	4400	6000	65	15.9
C2A 100L	3	2880	0.0042	84.6	84.7	83.2	0.84	0.78	0.67	6.1	9.95	2.5	4400	6000	69	23.8
C2A 112MT-a	4	2910	0.0056	85.8	86.3	86	0.84	0.78	0.67	8.0	13.13	2.6	4400	6000	69	28
C2A 132S-a	5.5	2880	0.0112	87	86.7	84.7	0.9	0.87	0.8	10.2	18.24	2.5	4400	6000	69	43.3
C2A 132S-b	7.5	2920	0.0146	87	87.6	87.2	0.9	0.88	0.82	13.8	24.53	2.6	4400	6000	71	49.5
C2A 160M-a	11	2935	0.031	89.4	89.5	87.7	0.88	0.85	0.77	20.2	36	2.8	4600	5000	71	76
C2A 160M-b	15	2936	0.041	90.3	90.5	89.4	0.89	0.85	0.78	27.0	49	2.8	4600	5000	72	90
C2A 160L	18.5	2938	0.048	90.9	91	90.3	0.89	0.85	0.78	33.0	60	2.9	4600	5000	72	110
C2A 180MT	22	2938	0.055	91.3	91.5	90	0.89	0.86	0.79	39.1	72	2.9	4600	5000	72	116
C2A 200LT-a	30	2945	0.105	92	92	91	0.91	0.89	0.85	51.8	97	2.8	4600	5000	81	162
C2A 200LT-b	37	2947	0.126	92.5	92.6	91.3	0.91	0.89	0.85	63.5	120	3	4800	5000	81	184
C2A 225MT⁽¹⁾	45	2960	0.18	92.9	92.9	91.4	0.9	0.88	0.8	77.8	145	3	4800	4800	81	222
C2A 250MT	55	2965	0.29	93.2	92.1	90.3	0.9	0.88	0.81	94.8	177	3	4800	4500	81	280
C2A 280ST	75	2965	0.553	93.8	93.3	91.1	0.9	0.88	0.84	128	242	2.7	4400	4500	84	408
C2A 280MT	90	2968	0.664	94.1	93.7	92	0.9	0.88	0.88	154	290	2.8	4400	4500	84	495
C2A 315ST	110	2970	0.751	94.3	94.8	93	0.9	0.88	0.89	187	354	2.8	4400	4500	84	553
C2A 315Ma	132	2875	1.53	94.6	94.7	93.2	0.9	0.88	0.84	224	438	1.9	3600	3600	87	692
C2A 315Mb	160	2875	1.83	94.8	94.7	94.3	0.9	0.89	0.86	271	531	1.9	3600	3600	87	764
C2A 315Mc	200	2875	1.83	95	94.9	93.5	0.9	0.89	0.86	338	664	2	3600	3600	87	860
Serie C2S - CS (carcassa in acciaio) - C2S - CS Series (steel frame)																
C2S 355L	250	2983	3.5	95.1	94	93.5	0.91	0.9	0.87	417	800	2	3600	3600	88	1200
C2S 355L-a	280	2980	4.2	95.1	94.1	93.5	0.91	0.9	0.87	468	898	2	3600	3600	88	1280
C2S 355L-b	315	2980	4.5	95.1	94.1	93.3	0.91	0.9	0.87	526	1010	2.3	3600	3600	88	1600
C2S 355Lx-a	355	2980	3.2	95.1	94.1	93.3	0.9	0.9	0.87	599	1202	2.2	3600	3600	89	1870
CS 355Lx-ab	400	2985	7.7	95.2	94.2	93.4	0.9	0.9	0.87	675	1280	2.2	3600	3600	89	2000
CS 355Lx-c	450	2985	8.4	95.2	94.2	93.4	0.9	0.9	0.87	759	1440	2.2	3600	3600	89	2150

I valori di rendimento sono calcolati in accordo con IEC 60034-2-1 con alimentazione sinusoidale.

Efficiency values are given according to IEC 60034-2-1 with sinusoidal supply.

Dati tecnici

ALIMENTAZIONE DA INVERTER

Classe di efficienza IE2 (IEC 60034-30; 2008)

Alta efficienza

Isolamento classe F - Sovratemperatura classe B

Servizio S1 - 400 V - 50 Hz

4 poli - 1.500 giri/min

Technical data

INVERTER SUPPLY

IE2 Efficiency class (IEC 60034-30; 2008)

High Efficiency

Insulation class F - Temperature rise class B

S1 Duty - 400 V - 50 Hz

4 poles - 1.500 rpm

Tipo Type	Potenza Power	Velocità Speed	J kgm ²	Rendimento Efficiency			Fattore di potenza Power factor cosφ			Corrente Current In (400 V)	Coppia nom. Nom. torque	Coppia Massima Max torque	Velocità max a potenza costante Max speed constant power	Velocità massima Max speed	Rumor. Noise	Forma B3 Mount B3 Peso Weight
	kW	giri/min rpm		100%	75%	50%	100%	75%	50%	A	Nm	Cmax/Cn Tmax/Tn	giri/min rpm	giri/min rpm	dB (A)	kg
Serie C2A (carcasa in alluminio) - C2A Series (aluminium frame)																
C2A 80-b	0.75	1360	0.0019	79.6	79	78	0.73	0.69	0.58	1.9	5.27	2.3	2300	6000	50	11
C2A 90S	1.1	1380	0.0028	81.4	81	79	0.78	0.72	0.6	2.5	7.61	2.5	2300	6000	50	14.2
C2A 90L	1.5	1380	0.0373	82.8	82	80	0.78	0.72	0.6	3.4	10.38	2.6	2300	6000	52	17.8
C2A 100L-a	2.2	1425	0.006	84.3	84.6	84.4	0.8	0.74	0.62	4.7	14.74	2.2	2200	6000	52	21.2
C2A 100L-b	3	1425	0.008	85.5	85.8	84.9	0.8	x	0.62	6.3	20.10	2.2	2200	6000	56	26.2
C2A 112M	4	1420	0.014	86.6	87.5	87.5	0.8	0.73	0.62	8.3	26.90	2.5	2400	6000	56	35
C2A 132S	5.5	1452	0.023	87.7	87.9	87	0.8	0.72	0.61	11.3	36.2	2.5	2400	6000	56	48
C2A 132M	7.5	1456	0.034	88.7	88.9	88	0.81	0.73	0.62	15.1	49.2	2.6	2500	6000	59	58
C2A 160M	11	1463	0.076	89.8	90	89.8	0.83	0.77	0.7	21.3	71.8	2.5	2500	5000	59	85.5
C2A 160L	15	1463	0.093	90.6	91	90.6	0.83	0.77	0.7	28.8	97.9	2.6	2500	5000	63	104
C2A 180MT	18.5	1462	0.11	91.2	91.4	91.1	0.83	0.77	0.63	35.3	120.8	2.5	2500	5000	63	125
C2A 180L	22	1462	0.153	91.6	92	91.6	0.87	0.83	0.74	39.9	143.7	2.6	2500	5000	63	155
C2A 200LT	30	1462	0.195	92.3	92.6	92.2	0.87	0.83	0.74	54.0	195.9	2.8	2700	5000	66	186
C2A 225ST	37	1470	0.352	92.7	92.7	92	0.87	0.83	0.74	69	240.3	2.9	2700	5000	66	230
C2A 225M	45	1474	0.429	93.1	93.2	93	0.88	0.82	0.74	84	292	2.9	2700	4500	66	263
C2A 250MT	55	1475	0.55	93.5	93.4	93	0.88	0.84	0.75	100	356	3	2700	4500	66	315
C2A 280ST	75	1480	1.25	94	93.8	93.7	0.88	0.85	0.76	134	484	2.6	2700	4500	70	407
C2A 280MT	90	1480	1.48	94.2	94	93.8	0.88	0.85	0.76	160	581	2.6	2700	4000	70	474
C2A 315M-a	110	1488	2.6	94.5	94.3	93.3	0.86	0.83	0.74	193	706	2.6	2700	3000	80	660
C2A 315M-b	132	1488	3.2	94.7	94.7	94	0.86	0.83	0.74	234	847	2.6	2700	3000	80	733
C2A 315M-c	160	1488	3.9	94.9	94.8	94	0.88	0.85	0.78	277	1027	2.7	2700	3000	80	848
C2A 315M-d	200	1485	4.7	95.1	95	94.2	0.88	0.85	0.78	345	1286	2.8	2700	3000	80	1026
Serie C2S - CS (carcasa in acciaio) - C2S - CS Series (steel frame)																
C2S 355L-a	250	1492	5.5	95.1	94.4	92.4	0.87	0.85	0.75	437	1600	3.8	2000	2000	84	1360
C2S 355L-b	280	1492	5.8	95.1	94.6	93	0.88	0.84	0.77	483	1792	3.8	2000	2000	84	1490
C2S 355L-c	315	1492	6.6	95.3	94.7	93	0.88	0.85	0.77	543	2016	4	2000	2000	84	1680
C2S 355Lx-a (*)	355	1492	10.0	95.3	94.8	93.3	0.89	0.87	0.81	605	2272	3.6	1900	1900	84	1850
CS 355Lx-b (*)	400	1492	11.8	95.5	94.9	93.7	0.89	0.88	0.81	680	2560	3.6	1900	1900	84	2060
CS 355Lx-c (*)	450	1492	13.6	95.7	95.2	94	0.90	0.87	0.81	755	2880	3.7	1900	1900	84	2260
CS 355Lx-d (*)	500	1492	15.9	95.8	95.2	94	0.90	0.87	0.81	838	3200	4	1900	1900	84	2520
CS 400Lx-a (*)	560	1495	27.0	96	95.4	94.2	0.87	0.83	0.76	969	3577	4	1900	1900	85	3150
CS 400Lx-b (*)	630	1490	31.6	96	95.4	94.2	0.87	0.83	0.76	1090	4037	4	1900	1900	85	3520
CS 450Lx-a	710	1495	36.0	96.5	96	95.2	0.89	0.87	0.84	1195	4535	3.5	1900	1900	85	4100
CS 450Lx-b	800	1495	41.8	96.7	96.2	95.2	0.89	0.87	0.84	1343	5110	3.8	1900	1900	85	4420
CS 500Lx-a (*)	900	1496	70.6	96.7	96.2	95.2	0.88	0.86	0.82	1528	5745	3.8	1900	1900	85	4950
CS 500Lx-c (*)	1000	1495	78.2	96.9	96.6	95.6	0.89	0.87	0.83	1676	6387	3.8	1900	1900	85	5300

(*) Sovratemperatura classe F

I valori di rendimento sono calcolati in accordo con IEC 60034-2-1 con alimentazione sinusoidale.

(*) Temperature rise class F

Efficiency values are given according to IEC 60034-2-1 with sinusoidal supply.

Dati tecnici

ALIMENTAZIONE DA INVERTER

Classe di efficienza IE2 (IEC 60034-30; 2008)

Alta efficienza

Isolamento classe F - Sovratemperatura classe B

Servizio S1 - 400 V - 50 Hz

6 poli - 1.000 giri/min

Technical data

INVERTER SUPPLY

IE2 Efficiency class (IEC 60034-30; 2008)

High Efficiency

Insulation class F - Temperature rise class B

S1 Duty - 400 V - 50 Hz

6 poles - 1.000 rpm

Tipo Type	Potenza Power	Velocità Speed	J	Rendimento Efficiency			Fattore di potenza Power factor cosφ			Corrente Current In (400 V)	Coppia nom. Nom. torque	Coppia Massima Max torque	Velocità max a potenza costante Max speed constant power	Velocità massima Max speed	Rumor. Noise	Forma B3 Mount B3 Peso Weight
	kW	giri/min rpm		100%	75%	50%	100%	75%	50%	A	Nm	Cmax/Cn Tmax/Tn	giri/min rpm	giri/min rpm	dB (A)	kg
Serie C2A (carcasa in alluminio) - C2A Series (aluminium frame)																
C2A 90S	0.75	925	0.005	75.9	74	68	0.66	0.55	0.4	2.16	7.74	2.9	1700	6000	54	13.5
C2A 90L	1.1	925	0.006	78.1	76	72	0.7	0.59	0.43	2.9	11.36	3	1700	6000	54	16.5
C2A 100L	1.5	950	0.013	79.8	77	72	0.71	0.58	0.44	3.8	15.08	2.5	1700	6000	57	25
C2A 112M	2.2	950	0.018	81.8	82	78	0.71	0.59	0.45	5.5	22.11	2.6	1700	6000	57	32
C2A 132S	3	955	0.029	83.3	83.3	81.2	0.72	0.61	0.47	7.2	30.00	2.8	1800	6000	60	45.5
C2A 132M-a	4	955	0.039	84.6	84.6	82.6	0.72	0.62	0.48	9.5	40.00	2.9	1800	6000	60	52.5
C2A 132M-b	5.5	955	0.051	86	86	84.3	0.73	0.63	0.49	12.7	55.0	3	1800	6000	60	69
C2A 160M	7.5	960	0.104	87.2	87.2	86	0.78	0.68	0.54	15.9	74.6	3	1800	5000	63	88
C2A 160L	11	965	0.123	88.7	88.4	87.2	0.78	0.69	0.54	23.0	108.8	3	1800	5000	63	114
C2A 180LT	15	970	0.16	89.7	89.2	87.8	0.78	0.69	0.54	31	147.7	3	1800	5000	63	125
C2A 200LT-a	18.5	980	0.38	90.4	90.6	89	0.86	0.81	0.7	34	180.3	2.8	1800	4500	68	134
C2A 200LT-b	22	980	0.45	90.9	91	89.9	0.86	0.81	0.7	41	214.4	2.9	1800	4500	68	155
C2A 225M	30	980	0.72	91.7	91.9	91.1	0.82	0.76	0.62	58	292	2.9	1800	4000	72	295
C2A 250MT	37	980	0.864	92.2	92.3	91.7	0.82	0.76	0.62	71	361	2.9	1800	3800	73	332
C2A 280ST	45	985	1.72	92.7	92.4	91.7	0.83	0.78	0.67	85	436	2.3	1500	3000	75	421
C2A 280MT	55	985	2.17	93.1	92.7	91.7	0.83	0.78	0.68	103	533	2.3	1500	3000	75	490
C2A 315ST	75	985	2.68	93.7	93.2	92.3	0.83	0.78	0.68	139	727	2.3	1500	3000	75	565
C2A 315M-a	90	988	3.14	94	93.5	92.4	0.83	0.8	0.68	167	870	2.7	1600	2800	82	672
C2A 315M-b	110	988	3.73	94.3	93.9	93.1	0.84	0.8	0.7	201	1063	2.7	1800	2800	82	730
C2A 315M-c	132	988	4.7	94.6	94.2	93.2	0.84	0.8	0.7	240	1276	2.9	1800	2800	82	910
C2A 315M-d	160	988	5.7	94.8	94.4	93.5	0.84	0.81	0.7	290	1546	2.9	1800	2800	82	1100
Serie C2S - CS (carcasa in acciaio) - C2S - CS Series (steel frame)																
C2S 355L	200	990	6.4	95.2	95.3	94.7	0.86	0.83	0.75	353	1929	2.9	2000	2000	82	1300
C2S 355L-a (*)	250	990	7.9	95.3	95.4	95	0.88	0.85	0.78	431	2411	3	2000	2000	82	1584
C2S 355L-b (*)	280	990	8.7	95.3	95.5	95.2	0.88	0.85	0.79	482	2701	3	2000	2000	82	1744
C2S 355L-c (*)	315	990	9.8	95.4	95.6	95.3	0.88	0.85	0.79	542	3038	3	2000	2000	82	1968
C2S 355Lx-a (*)	355	990	19.8	95.5	95.5	95.4	0.89	0.87	0.79	604	3424	3.4	1900	1900	82	2060
CS 355Lx-b (*)	400	990	22.3	95.5	95.6	95.5	0.89	0.87	0.79	680	3858	3.4	1900	1900	82	2254
CS 400Lx-a (*)	450	994	31.1	95.6	95.5	94.8	0.89	0.87	0.79	764	4323	3.4	1900	1900	84	2960
CS 400Lx-b	500	994	35.0	95.7	95.7	94.9	0.89	0.87	0.79	848	4803	3.5	1800	1800	84	3290
CS 400Lx-c	560	995	39.8	95.7	95.7	94.9	0.89	0.87	0.79	950	5374	3.5	1800	1800	84	3530
CS 450Lx-a	630	995	60.0	96	95.9	95	0.88	0.85	0.78	1078	6046	3.5	1800	1800	84	4200
CS 450Lx-b	710	995	68.0	96	95.9	95	0.88	0.85	0.78	1215	6814	3	1800	1800	85	4560
CS 500Lx-a	800	995	74.0	96.3	96.3	95.8	0.89	0.87	0.80	1349	7678	3	1800	1800	85	4890
CS 500Lx-b	900	995	86.0	96.4	96.4	95.8	0.89	0.87	0.80	1516	8637	3	1800	1800	85	5500
CS 500Lx-c (*)	1000	996	103.0	96.5	96.4	95.8	0.89	0.87	0.80	1683	9587	3	1800	1800	85	6100
CS 500Lx-d (*)	1100	996	107.0	96.6	96.4	95.8	0.89	0.87	0.80	1849	10546	3	1800	1800	85	6300

(*) Sovratemperatura classe F

I valori di rendimento sono calcolati in accordo con IEC 60034-2-1 con alimentazione sinusoidale.

(*) Temperature rise class F

Efficiency values are given according to IEC 60034-2-1 with sinusoidal supply.

Dati tecnici

ALIMENTAZIONE DA INVERTER

Classe di efficienza IE2 (IEC 60034-30; 2008)

Alta efficienza

Isolamento classe F - Sovratemperatura classe B

Servizio S1 - 690 V - 50 Hz

2 poli - 3.000 giri/min

Technical data

INVERTER SUPPLY

IE2 Efficiency class (IEC 60034-30; 2008)

High Efficiency

Insulation class F - Temperature rise class B

S1 Duty - 690 V - 50 Hz

2 poles - 3.000 rpm

Tipo Type	Potenza Power	Velocità Speed	J	Rendimento Efficiency			Fattore di potenza Power factor cosφ			Corrente Current In (690 V)	Coppia nom. Nom. torque	Coppia Massima Max torque	Velocità max a potenza costante Max speed costant power	Velocità massima Max speed	Rumor. Noise	Forma B3 Mount B3 Peso Weight
	kW	giri/min rpm		kgm ²	100%	75%	50%	100%	75%	50%	A	Nm	Cmax/Cn Tmax/Tn	giri/min rpm	giri/min rpm	dB (A)
Serie C2A (carcassa in alluminio) - C2A Series (aluminium frame)																
C2A 315Ma	132	2980	1.43	94.6	94.2	92.7	0.9	0.88	0.84	129	423	2.7	3660	3600	87	692
C2A 315Mb	160	2980	1.67	94.8	94.5	93.5	0.9	0.89	0.86	157	513	2.7	3600	3600	87	764
C2A 315Mc	200	2980	1.83	95	94.9	93.5	0.9	0.89	0.86	195	641	2.7	3600	3600	87	840
Serie C2S (carcassa in acciaio) - C2S Series (steel frame)																
C2S 355L	250	2983	3.5	95.1	94	93.5	0.91	0.9	0.87	241	800	2	3600	3600	88	1200
C2S 355L-a	280	2980	4.2	95.1	94.1	93.5	0.91	0.9	0.87	270	898	2	3600	3600	88	1280
C2S 355L-b	315	2980	4.5	95.1	94.1	93.3	0.91	0.9	0.87	30'4	1010	2.3	3600	3600	88	1600
C2S 355Lx-a	355	2980	3.2	95.1	94.1	93.3	0.9	0.9	0.87	346	1202	2.2	3600	3600	89	1870
C2S 355Lx-b	400	2985	7.7	95.2	94.2	93.4	0.9	0.9	0.87	390	1280	2.2	3600	3600	89	2000
C2S 355Lx-c	450	2985	8.4	95.2	94.2	93.4	0.9	0.9	0.87	439	1440	2.2	3600	3600	89	2150

I valori di rendimento sono calcolati in accordo con IEC 60034-2-1 con alimentazione sinusoidale.

Efficiency values are given according to IEC 60034-2-1 with sinusoidal supply.

Dati tecnici

ALIMENTAZIONE DA INVERTER

Classe di efficienza IE2 (IEC 60034-30; 2008)

Alta efficienza

Isolamento classe F - Sovratemperatura classe B

Servizio S1 - 690 V - 50 Hz

4 poli - 1.500 giri/min

Technical data

INVERTER SUPPLY

IE2 Efficiency class (IEC 60034-30; 2008)

High Efficiency

Insulation class F - Temperature rise class B

S1 Duty - 690 V - 50 Hz

4 poles - 1.500 rpm

Tipo Type	Potenza Power	Velocità Speed	J	Rendimento Efficiency			Fattore di potenza Power factor cosφ			Corrente Current In (690 V)	Coppia nom. Nom. torque	Coppia Massima Max torque	Velocità max a potenza costante Max speed constant power	Velocità massima Max speed	Rumor. Noise	Forma B3 Mount B3 Peso Weight
	kW	giri/min rpm		100%	75%	50%	100%	75%	50%	A	Nm	Cmax/Cn Tmax/Tn	giri/min rpm	giri/min rpm	dB (A)	kg
Serie C2A (carcassa in alluminio) - C2A Series (aluminium frame)																
C2A 315M-a	110	1488	2.6	94.5	94.3	93.3	0.86	0.83	0.74	113	706	2.6	2700	4000	74	476
C2A 315M-b	132	1488	3.2	94.7	94.7	94	0.86	0.83	0.74	136	847	2.6	2700	4000	74	733
C2A 315M-c	160	1488	3.9	94.9	94.8	94	0.88	0.85	0.78	161	1027	2.7	2700	4000	74	848
C2A 315M-d	200	1485	4.7	95.1	95	94.2	0.88	0.85	0.78	200	1286	2.8	2700	4000	74	1026
Serie C2S - CS (carcassa in acciaio) - C2S - CS Series (steel frame)																
C2S 355L-a	250	1490	4.7	95.1	95.0	93.6	0.89	0.87	0.79	426.8	1602	3.8	2000	2000	84	1360
C2S 355L-b	280	1490	5.2	95.1	95	93.6	0.89	0.87	0.79	478	1794	3.8	2000	2000	84	1490
C2S 355L-c	315	1490	5.7	95.3	95.0	93.6	0.89	0.87	0.79	537	2019	4	2000	2000	84	1680
C2S 355Lx-a (*)	355	1492	10.0	95.3	94.8	93.3	0.89	0.87	0.81	351	2272	3.6	1900	1900	84	1850
CS 355Lx-b (*)	400	1492	11.8	95.5	94.9	93.7	0.89	0.88	0.81	394	2560	3.6	1900	1900	84	2060
CS 355Lx-c (*)	450	1492	13.6	95.7	95.2	94	0.90	0.87	0.81	438	2880	3.7	1900	1900	84	2260
CS 355Lx-d (*)	500	1492	15.9	95.8	95.2	94	0.90	0.87	0.81	486	3200	4	1900	1900	84	2520
CS 400Lx-a (*)	560	1495	27.0	96	95.4	94.2	0.89	0.87	0.78	549	3577	4	1900	1900	85	3150
CS 400Lx-b (*)	630	1495	31.6	96	95.4	94.2	0.89	0.87	0.78	618	4024	4	1900	1900	85	3520
CS 450Lx-a	710	1495	36.0	96.4	96	95.2	0.91	0.90	0.85	678	4535	3.5	1900	1900	85	4100
CS 450Lx-b	800	1495	41.8	96.5	96	95.2	0.91	0.90	0.85	763	5110	3.8	1900	1900	85	4420
CS 500Lx-a (*)	900	1496	70.6	96.6	96.2	95.2	0.92	0.90	0.85	848	5745	3.8	1900	1900	85	4950
CS 500Lx-c (*)	1000	1495	78.2	96.8	96.6	95.6	0.92	0.90	0.85	941	6387	3.8	1900	1900	85	5300
CS 500Lx-d (*)	1100	1496	87.0	96.6	96.6	95.6	0.92	0.90	0.85	1037	7021	3.8	1900	1900	85	5800
CS 500Lx-e (*)	1200	1496	102.1	96.8	96.6	95.6	0.92	0.90	0.85	1129	7660	3.8	1900	1900	85	6600

(*) Sovratemperatura classe F

I valori di rendimento sono calcolati in accordo con IEC 60034-2-1 con alimentazione sinusoidale.

(*) Temperature rise class F

Efficiency values are given according to IEC 60034-2-1 with sinusoidal supply.

Dati tecnici

ALIMENTAZIONE DA INVERTER

Classe di efficienza IE2 (IEC 60034-30; 2008)

Alta efficienza

Isolamento classe F - Sovratemperatura classe B

Servizio S1 - 690 V - 50 Hz

6 poli - 1.000 giri/min

Technical data

INVERTER SUPPLY

IE2 Efficiency class (IEC 60034-30; 2008)

High Efficiency

Insulation class F - Temperature rise class B

S1 Duty - 690 V - 50 Hz

6 poles - 1.000 rpm

Tipo Type	Potenza Power	Velocità Speed	J	Rendimento Efficiency			Fattore di potenza Power factor cosφ			Corrente Current In (690 V)	Coppia nom. Nom. torque	Coppia massima Max torque	Velocità max a potenza costante Max speed constant power	Velocità max Max speed	Rumor. Noise	Forma B3 Mount B3 Peso Weight
	kW	giri/min rpm		kgm ²	100%	75%	50%	100%	75%	50%	A	Nm	Cmax/Cn Tmax/Tn	giri/min rpm	giri/min rpm	dB (A)
Serie C2A (carcassa in alluminio) - C2A Series (aluminium frame)																
C2A 315M-a	90	988	3.14	94	93.5	92.4	0.83	0.8	0.68	97	870	2.7	1600	2800	82	672
C2A 315M-b	110	988	3.73	94.3	93.9	93.1	0.84	0.8	0.7	116	1063	2.7	1800	2800	82	730
C2A 315M-c	132	988	4.7	94.6	94.2	93.2	0.84	0.8	0.7	139	1276	2.9	1800	2800	82	910
C2A 315M-d	160	988	5.7	94.8	94.4	93.5	0.84	0.81	0.7	168	1546	2.9	1800	2800	82	1100
Serie C2S - CS (carcassa in acciaio) - C2S - CS Series (steel frame)																
C2S 355L	200	990	6.4	95.2	95.3	94.7	0.86	0.83	0.75	205	1929	2.9	2000	2000	82	1300
C2S 355L-a (*)	250	990	7.9	95.3	95.4	95	0.88	0.85	0.78	250	2411	3	2000	2000	82	1584
C2S 355L-b (*)	280	990	8.7	95.3	95.5	95.2	0.88	0.85	0.79	280	2701	3	2000	2000	82	1744
C2S 355L-c (*)	315	990	9.8	95.4	95.6	95.3	0.88	0.85	0.79	314	3038	3	2000	2000	82	1968
C2S 355Lx-a (*)	355	990	19.8	95.5	95.5	95.4	0.89	0.87	0.79	349	3424	3.4	1900	1900	82	2060
CS 355Lx-b (*)	400	990	22.3	95.5	95.6	95.5	0.89	0.87	0.79	393	3858	3.4	1900	1900	82	2254
CS 400Lx-a (*)	450	994	31.1	95.6	95.5	94.8	0.89	0.87	0.79	442	4323	3.4	1900	1900	84	2960
CS 400Lx-b	500	994	35.0	95.7	95.7	94.9	0.89	0.87	0.79	490	4803	3.5	1800	1800	84	3290
CS 400Lx-c	560	995	39.8	95.7	95.7	94.9	0.89	0.87	0.79	549	5374	3.5	1800	1800	84	3530
CS 450Lx-a	630	995	60.0	96	95.9	95	0.88	0.85	0.78	623	6046	3.5	1800	1800	84	4200
CS 450Lx-b	710	995	68.0	96	95.9	95	0.88	0.85	0.78	702	6814	3	1800	1800	85	4560
CS 500Lx-a	800	995	74.0	96.3	96.3	95.8	0.89	0.87	0.80	780	7678	3	1800	1800	85	4890
CS 500Lx-b	900	995	86.0	96.4	96.4	95.8	0.89	0.87	0.80	876	8637	3	1800	1800	85	5500
CS 500Lx-c (*)	1000	996	103.0	96.5	96.4	95.8	0.89	0.87	0.80	973	9587	3	1800	1800	85	6100
CS 500Lx-d (*)	1100	996	107.0	96.6	96.4	95.8	0.89	0.87	0.80	1069	10546	3	1800	1800	85	6300

(*) Sovratemperatura classe F

I valori di rendimento sono calcolati in accordo con IEC 60034-2-1 con alimentazione sinusoidale.

(*) Temperature rise class F

Efficiency values are given according to IEC 60034-2-1 with sinusoidal supply.

Dati tecnici

Technical data

ALIMENTAZIONE DA INVERTER

Isolamento classe F - Servizio S1 - 690 V - 50 Hz
8 poli - 750 giri/min

INVERTER SUPPLY

Insulation class F - S1 Duty - 690 V - 50 Hz
8 poles - 750 rpm

Tipo Type	Potenza Power	Velocità Speed	J	Rend. Eff.	Fattore di potenza Power factor	Corrente Current In (690 V)	Coppia nom. Nominal torque	Coppia massima Max torque	Velocità max a potenza costante Max speed constant power	Velocità max Max speed	Rumor. Noise	Forma B3 Mount B3 Peso Weight
	kW	giri/min rpm	kgm ²	%	cosφ	A	Nm	Cmax/Cn Tmax/Tn	giri/min rpm	giri/min rpm	dB (A)	kg
Serie CA (carcassa in alluminio) - CA Series (aluminium frame)												
CA 315M	75	740	3.1	93	0.8	84	968	2.2	1400	2600	81	671
CA 315M	90	740	3.52	93.5	0.8	101	1162	2.3	1400	2600	81	769
CA 315M	110	740	4.4	93.8	0.8	123	1420	2.3	1400	2600	81	890
CA 315M	132	740	5.1	94	0.8	147	1704	2.4	1400	2600	81	1035
Serie CS (carcassa in acciaio) - CS Series (steel frame)												
CS 355L-a	160	740	8.7	94.3	0.81	175	2065	3.4	1500	2600	79	1300
CS 355L-b	200	742	10.5	94.5	0.82	216	2575	3.4	1500	2600	79	1620
CS 355L-c	250	745	12.6	94.5	0.82	269	3205	3.4	1500	2600	79	1968
CS 355Lx-a	315	745	26.6	95	0.80	347	4039	3	1500	2400	79	2520
CS 355Lx-b	355	745	31.3	95	0.81	386	4550	3	1500	2400	81	2840
CS 400Lx-b	400	745	47.2	95.6	0.86	406	5127	3.2	1400	2200	81	3440
CS 400Lx-c	450	745	54.0	95.6	0.86	457	5768	3.4	1400	2200	83	3600
CS 450Lx-a	500	745	81.4	95.6	0.87	502	6409	3.2	1400	1900	83	4140
CS 450Lx-b	560	745	93.0	95.8	0.87	561	7178	3.4	1400	1900	83	4590
CS 500Lx-a	630	745	108.9	96	0.87	630	8075	3.4	1300	1800	83	5050
CS 500Lx-b	710	745	120.6	96.2	0.87	709	9100	3.4	1300	1800	83	5440
CS 500Lx-c	800	745	137.4	96.3	0.87	798	10254	3.4	1300	1800	79	5980

I valori di rendimento sono calcolati con alimentazione sinusoidale.

Efficiency values are given with sinusoidal supply.

Dati tecnici

ALIMENTAZIONE DA INVERTER

Classe di efficienza IE3 (IEC 60034-30; 2008)

Efficienza Premium

Isolamento classe F - Sovratemperatura classe B

Servizio S1 - 400 V - 50 Hz

2 poli - 3.000 giri/min

Technical data

INVERTER SUPPLY

IE3 Efficiency class (IEC 60034-30; 2008)

Premium Efficiency

Insulation class F - Temperature rise class B

S1 Duty - 400 V - 50 Hz

2 poles - 3.000 rpm

Tipo Type	Potenza Power	Velocità Speed	J kgm ²	Rendimento Efficiency			Fattore di potenza Power factor cosφ			Corrente Current In (400 V)	Coppia nom. Nom. torque	Coppia Massima Max torque	Velocità max a potenza costante Max speed constant power	Velocità massima Max speed	Rumor. Noise	Forma B3 Mount B3 Peso Weight
	kW	giri/min rpm		100%	75%	50%	100%	75%	50%	A	Nm	Cmax/Cn Tmax/Tn	giri/min rpm	giri/min rpm	dB (A)	kg
Serie C3A (carcassa in alluminio) - C3A Series (aluminium frame)																
C3A 80-a	0.75	2860	0.00145	80.7	80	76	0.87	0.85	0.78	1.5	2.504	2.8	4600	6000	60	11.2
C3A 80-b	1.1	2875	0.0020	82.7	82.5	80	0.88	0.72	0.79	2.2	3.654	2.8	4600	6000	60	13.2
C3A 90S	1.5	2937	0.0016	84.2	83.4	81	0.76	0.64	0.64	3.4	4.877	3.2	4400	6000	64	13.9
C3A 90L	2.2	2840	0.0022	85.9	85.4	84.3	0.86	0.81	0.69	4.3	7.397	3	4400	6000	64	15.9
C3A 100L	3	2900	0.0054	87.1	87.1	86.8	0.86	0.81	0.7	5.8	9.88	3	4400	6000	68	28
C3A 112M	4	2895	0.0083	88.1	88	86.8	0.86	0.81	0.7	7.6	13.19	3	4400	6000	68	33
C3A 132S-b	5.5	2910	0.0143	89.2	89.3	98.0	0.89	0.87	0.81	10.0	18.05	3	4400	6000	70	49.5
C3A 132S-b	7.5	2930	0.016	90.1	91	89.4	0.89	0.87	0.81	13.5	24.4	3	4600	5000	70	53
C3A 160M-a	11	2947	0.041	91.2	91	89.4	0.9	0.88	0.81	19.4	36	3.4	4600	5000	70	90
C3A 160M-b	15	2947	0.048	91.9	91.8	90.0	0.89	0.86	0.78	26.5	49	3.4	4600	5000	70	110
C3A 160L	18.5	2948	0.055	92.4	92.0	90.6	0.88	0.85	0.74	32.9	60	3	4600	5000	70	116
C3A 180L-T	22	2960	0.060	92.7	92	91.1	0.89	0.86	0.78	38.5	71	3.4	4600	5000	71	160
C3A 200LT	30	2960	0.126	93.3	93.2	92.1	0.9	0.87	0.80	51.6	97	3.5	4600	5000	78	184
C3A 200L	37	2965	0.182	93.7	93.3	92	0.9	0.87	0.80	63.4	119	3.3	4600	5000	78	220
C3A 225MT	45	2965	0.182	94.0	93.4	92.4	0.9	0.88	0.81	76.0	145	3.2	4600	5000	78	220
C3A 250MT	55	2970	0.349	94.3	93.7	92.5	0.9	0.89	0.84	92.6	177	3	4400	4500	78	330
C3A 280ST	75	2970	0.707	94.7	94.6	93.8	0.91	0.90	0.87	126	241	2.7	4200	4200	82	495
C3A 280MT	90	2970	0.840	95	94.7	93.7	0.91	0.90	0.87	150	289	3	4200	4200	82	550
C3A 315S	110	2973	1.531	95.2	94.8	93.7	0.91	0.9	0.87	183	353	2.4	3600	3600	84	750
C3A 315Ma	132	2973	1.837	95.4	95.1	94.2	0.91	0.9	0.89	220	424	2.4	3600	3600	84	810
C3A 315Md	160	2973	2.143	95.6	95.5	94.8	0.91	0.91	0.9	266	514	2.5	3600	3600	84	916
C3A 315Me	200	2975	2.449	95.8	95.7	95.4	0.91	0.91	0.89	332	642	2.5	3600	3600	84	1005
Serie C3S (carcassa in acciaio) - C3S Series (steel frame)																
C3S 355L-a	250	2982	4.35	95.8	95.5	94.6	0.91	0.91	0.88	414	801	2.3	3600	3600	85	1560
C3S 355L-b	280	2983	4.69	95.8	95.6	94.8	0.91	0.91	0.88	464	898	2.4	3600	3600	85	1720
C3S 355Lx-a	315	2985	6.23	95.8	95.7	94.8	0.91	0.91	0.89	522	1010	2.3	3600	3600	85	1800
C3S 355Lx-b	355	2985	6.82	95.8	95.7	95.1	0.91	0.9	0.89	588	1202	2.4	3600	3600	85	1900

I valori di rendimento sono calcolati in accordo con IEC 60034-2-1 con alimentazione sinusoidale.

Efficiency values are given according to IEC 60034-2-1 with sinusoidal supply.

Dati tecnici

ALIMENTAZIONE DA INVERTER

Classe di efficienza IE3 (IEC 60034-30; 2008)

Efficienza Premium

Isolamento classe F - Sovratemperatura classe B

Servizio S1 - 400 V - 50 Hz

4 poli - 1.500 giri/min

Technical data

INVERTER SUPPLY

IE3 Efficiency class (IEC 60034-30; 2008)

Premium Efficiency

Insulation class F - Temperature rise class B

S1 Duty - 400 V - 50 Hz

4 poles - 1.500 rpm

Tipo Type	Potenza Power	Velocità Speed	J kgm ²	Rendimento Efficiency			Fattore di potenza Power factor cosφ			Corrente Current In (400 V)	Coppia nom. Nom. torque	Coppia Massima Max torque	Velocità max a potenza costante Max speed constant power	Velocità massima Max speed	Rumor. Noise	Forma B3 Mount B3 Peso Weight
	kW	giri/min rpm		100%	75%	50%	100%	75%	50%	A	Nm	Cmax/Cn Tmax/Tn	giri/min rpm	giri/min rpm	dB (A)	kg
Serie C3A (carcassa in alluminio) - C3A Series (aluminium frame)																
C3A 80-b	0.75	1360	0.0019	82.5	79	78	0.73	0.69	0.58	1.8	5.27	2.3	2300	6000	50	11
C3A 90S	1.1	1428	0.0034	84.1	83	79	0.74	0.64	0.48	2.6	7.36	3.1	2500	6000	51	16
C3A 90L	1.5	1430	0.0040	85.3	84	81	0.75	0.65	0.5	3.4	10.02	3.2	2500	6000	51	18.4
C3A 100L-a	2.2	1435	0.0083	86.7	86.3	84.3	0.75	0.66	0.52	4.9	14.64	3.4	2500	6000	54	26.2
C3A 100L-b	3	1425	0.0097	85.5	85.8	84.9	0.78	0.73	0.62	6.5	20.10	3.5	2700	6000	54	29
C3A 112M	4	1435	0.0198	88.6	88.3	87.0	0.78	0.70	0.56	8.4	26.62	3	2700	6000	54	48
C3A 132sa	5.5	1463	0.033	89.6	89.6	88.4	0.78	0.70	0.56	11.4	35.9	2.8	2700	6000	54	58
C3A 132Ma	7.5	1463	0.037	90.4	90.0	88.0	0.78	0.70	0.57	15.37	49.0	2.8	2700	6000	54	65
C3A 160M	11	1470	0.092	91.4	91.4	91.0	0.81	0.75	0.62	21.5	71.5	2.7	2700	5000	58	104
C3A 160L	15	1470	0.108	92.1	92.0	91.8	0.84	0.79	0.70	28.0	97.4	2.6	2600	5000	62	125
C3A 180MT	18.5	1470	0.117	92.6	92.2	92.0	0.8	0.79	0.68	35	120.2	2.6	2600	5000	62	133
C3A 180L	22	1471	0.194	93	92.7	91.3	0.82	0.77	0.65	42	142.8	3.2	3000	5000	62	180
C3A 200L	30	1471	0.373	93.6	93.4	92.6	0.86	0.82	0.70	54	194.7	3	3000	5000	64	230
C3A 225ST	37	1473	0.397	93.9	93.4	92.6	0.86	0.82	0.7	66	239.9	3.2	3000	5000	64	242
C3A 225M	45	1476	0.549	94.2	94.0	93.3	0.88	0.84	0.73	78	291	3.4	3000	5000	64	310
C3A 250M	55	1480	0.977	94.6	94.4	93.8	0.88	0.84	0.77	95	355	2.6	2700	4500	65	360
C3A 280ST	75	1480	1.486	95	94.8	94.5	0.88	0.85	0.78	130	484	2.6	2700	4500	69	474
C3A 280MT	90	1482	1.720	95.2	95.1	94.5	0.88	0.85	0.78	155	580	2.7	2700	4000	69	532
C3A 315S	110	1484	3.310	95.4	95.4	94.6	0.88	0.86	0.80	189	708	2.5	2500	3000	78	733
C3A 315M-b	132	1487	3.310	95.5	95.8	95.4	0.88	0.86	0.80	227	848	2.5	2500	3000	78	733
C3A 315M-c	160	1485	3.972	95.8	95.8	95.3	0.88	0.86	0.80	274	1029	2.7	2500	3000	78	848
C3A 315M-d	200	1486	4.800	96.0	95.9	95.6	0.88	0.86	0.78	342	1285	2.9	2500	3000	78	1026
Serie C3S (carcassa in acciaio) - C3S Series (steel frame)																
C3S 355L-b	250	1488	4.760	96.0	96.0	95.2	0.88	0.86	0.77	428	1604	2.5	2000	2000	84	1480
C3S 355L-c	315	1488	5.752	96	96	95.5	0.88	0.87	0.80	539	2021	2.5	2000	2000	84	1680
C3S 355Lx-a	355	1492	11.657	96	96	95.6	0.89	0.88	0.83	600	2272	2.4	2000	2000	84	1960

I valori di rendimento sono calcolati in accordo con IEC 60034-2-1 con alimentazione sinusoidale.

Efficiency values are given according to IEC 60034-2-1 with sinusoidal supply.

Dati tecnici

ALIMENTAZIONE DA INVERTER

Classe di efficienza IE3 (IEC 60034-30; 2008)

Efficienza Premium

Isolamento classe F - Sovratemperatura classe B

Servizio S1 - 400 V - 50 Hz

6 poli - 1.000 giri/min

Technical data

INVERTER SUPPLY

IE3 Efficiency class (IEC 60034-30; 2008)

Premium Efficiency

Insulation class F - Temperature rise class B

S1 Duty - 400 V - 50 Hz

6 poles - 1.000 rpm

Tipo Type	Potenza Power	Velocità Speed	J	Rendimento Efficiency			Fattore di potenza Power factor cosφ			Corrente Current In (400 V)	Coppia nom. Nom. torque	Coppia Massima Max torque	Velocità max a potenza costante Max speed constant power	Velocità massima Max speed	Rumor. Noise	Forma B3 Mount B3 Peso Weight
	kW	giri/min rpm	kgm ²	100%	75%	50%	100%	75%	50%	A	Nm	Cmax/Cn Tmax/Tn	giri/min rpm	giri/min rpm	dB (A)	kg
Serie C3A (carcassa in alluminio) - C3A Series (aluminium frame)																
C3A 90S	0.75	926	0.0060	78.9	77	72	0.67	0.56	0.42	2.05	7.7	2.9	1800	6000	54	11
C3A 90L	1.1	925	0.0072	81	80	77	0.69	0.58	0.44	2.8	11.4	3.2	1800	6000	54	13.6
C3A 100L	1.5	950	0.0134	82.5	81	77	0.69	0.58	0.44	3.8	15.1	2.8	1800	6000	56	25
C3A 112M	2.2	950	0.0242	84.3	83.5	81	0.72	0.63	0.5	5.2	22.1	2.6	1800	6000	56	44
C3A 132S	3	954	0.0389	85.6	85.5	84	0.75	0.67	0.53	6.8	30.0	2.8	1800	6000	59	52.5
C3A 132M-a	4	956	0.0511	86.8	86.8	85.6	0.76	0.67	0.53	8.8	40.0	2.9	1800	6000	59	69
C3A132M-b	5.5	957	0.0584	88	87.6	86.4	0.76	0.67	0.53	11.9	54.9	3	1800	6000	59	77
C3A 160M	7.5	960	0.135	89.1	89	88.9	0.82	0.76	0.63	14.8	74.6	2.9	1800	5000	63	104
C3A 160L	11	965	0.159	90.3	90.2	89.6	0.8	0.73	0.6	22.0	108.8	3	1800	5000	63	125
C3A 180L	15	981	0.330	91.2	91.2	90.0	0.8	0.73	0.62	28.3	146	2.8	1700	5000	63	163
C3A 200LT	18.5	981	0.377	91.7	91.6	91.3	0.85	0.80	0.68	34.3	180	2.8	1700	4500	68	180
C3A 200L-b	22	982	0.483	92.2	92.2	91.6	0.85	0.80	0.68	41	214	2.9	1700	4500	70	210
C3A 225M	30	983	0.92	92.9	92.7	92.4	0.85	0.80	0.69	55	291	2.9	1700	4000	72	310
C3A 250M	37	992	1.72	93.3	93.2	92.2	0.83	0.78	0.69	69	356	2.4	1600	3800	75	340
C3A 280ST	45	993	2.17	93.7	93.6	92.4	0.83	0.78	0.70	84	433	2.5	1600	3000	75	435
C3A 280MT	55	985	2.68	94.1	94.1	93.6	0.83	0.78	0.67	102	533	2.8	1700	3000	75	514
C3A 315S	75	988	3.14	94.6	94.4	93.7	0.84	0.78	0.68	136	725	2.3	1600	2800	82	672
C3A 315M-a	90	989	3.63	94.9	94.8	93.7	0.84	0.78	0.68	163	869	2.7	1700	2800	82	730
C3A 315M-b	110	989	4.71	95.1	95	94.4	0.84	0.79	0.69	199	1062	2.8	1700	2800	82	919
C3A 315M-d	132	989	5.69	95.4	95.3	94.9	0.84	0.8	0.721	238	1274	2.9	1700	2800	82	1100
Serie C3S (carcassa in acciaio) - C3S Series (steel frame)																
C3S 355L-a	160	990	6.39	94.8	94.4	93.5	0.84	0.81	0.7	290	1543	2.4	1600	2000	82	1300
C3S 355L-b	200	990	7.98	95.8	95.3	94.7	0.86	0.83	0.75	351	1929	2.4	1600	2000	82	1584
C3S 355L-c	250	990	8.71	95.8	95.6	95	0.86	0.83	0.75	439	2411	2.5	1600	2000	82	1744
C3S 355Lx-a	280	992	11.50	95.8	95.7	95.1	0.83	0.8	0.72	509	2695	1.9	1500	1900	82	1960
C3S 355Lx-b	315	992	13.18	95.8	95.8	95.4	0.83	0.81	0.74	572	3032	1.9	1500	1900	82	2060
C3S 355Lx-c	355	992	14.38	95.8	95.8	95.7	0.83	0.81	0.74	645	3417	2	1500	1900	82	2200

I valori di rendimento sono calcolati in accordo con IEC 60034-2-1 con alimentazione sinusoidale.

Efficiency values are given according to IEC 60034-2-1 with sinusoidal supply.

Dati tecnici

ALIMENTAZIONE DA INVERTER

Classe di efficienza IE3 (IEC 60034-30; 2008)

Alta efficienza

Isolamento classe F - Sovratemperatura classe B

Servizio S1 - 690 V - 50 Hz

2 poli - 3.000 giri/min

Technical data

INVERTER SUPPLY

IE3 Efficiency class (IEC 60034-30; 2008)

High Efficiency

Insulation class F - Temperature rise class B

S1 Duty - 690 V - 50 Hz

2 poles - 3.000 rpm

Tipo Type	Potenza Power	Velocità Speed	J	Rendimento Efficiency			Fattore di potenza Power factor cosφ			Corrente Current In (690 V)	Coppia nom. Nom. torque	Coppia Massima Max torque	Velocità max a potenza costante Max speed costant power	Velocità massima Max speed	Rumor. Noise	Forma B3 Mount B3 Peso Weight
	kW	giri/min rpm		kgm ²	100%	75%	50%	100%	75%	50%	A	Nm	Cmax/Cn Tmax/Tn	giri/min rpm	giri/min rpm	dB (A)
Serie C3A (carcasa in alluminio) - C3A Series (aluminium frame)																
C3A 315S	110	2973	1.531	95.2	94.8	93.7	0.91	0.9	0.87	106	353	2.4	3600	3600	84	750
C3A 315Ma	132	2973	1.837	95.4	95.1	94.2	0.91	0.9	0.89	127	424	2.4	3600	3600	84	810
C3A 315Md	160	2973	2.143	95.6	95.5	94.8	0.91	0.91	0.9	154	514	2.5	3600	3600	84	916
C3A 315Me	200	2975	2.449	95.8	95.7	95.4	0.91	0.91	0.89	192	642	2.5	3600	3600	84	1005
Serie C3S (carcasa in acciaio) - C3S Series (steel frame)																
C3S 355L-a	250	2982	4.35	95.8	95.5	94.6	0.91	0.91	0.88	239	801	2.3	3600	3600	85	1560
C3S 355L-b	280	2983	4.69	95.8	95.6	94.8	0.91	0.91	0.88	268	898	2.4	3600	3600	85	1720
C3S 355Lx-a	315	2985	6.23	95.8	95.7	94.8	0.91	0.91	0.89	302	1010	2.3	3600	3600	85	1800
C3S 355Lx-b	355	2985	6.82	95.8	95.7	95.1	0.91	0.9	0.89	340	1202	2.4	3600	3600	85	1900

I valori di rendimento sono calcolati in accordo con IEC 60034-2-1 con alimentazione sinusoidale.

Efficiency values are given according to IEC 60034-2-1 with sinusoidal supply.

Dati tecnici

ALIMENTAZIONE DA INVERTER

Classe di efficienza IE3 (IEC 60034-30; 2008)

Alta efficienza

Isolamento classe F - Sovratemperatura classe B

Servizio S1 - 690 V - 50 Hz

4 poli - 1.500 giri/min

Technical data

INVERTER SUPPLY

IE3 Efficiency class (IEC 60034-30; 2008)

High Efficiency

Insulation class F - Temperature rise class B

S1 Duty - 690 V - 50 Hz

4 poles - 1.500 rpm

Tipo Type	Potenza Power	Velocità Speed	J	Rendimento Efficiency			Fattore di potenza Power factor cosφ			Corrente Current In (690 V)	Coppia nom. Nom. torque	Coppia Massima Max torque	Velocità max a potenza costante Max speed costant power	Velocità massima Max speed	Rumor. Noise	Forma B3 Mount B3 Peso Weight
	kW	giri/min rpm		kgm ²	100%	75%	50%	100%	75%	50%	A	Nm	Cmax/Cn Tmax/Tn	giri/min rpm	giri/min rpm	dB (A)
Serie C3A (carcassa in alluminio) - C3A Series (aluminium frame)																
C3A 315S	110	1484	3.310	95.4	95.4	94.6	0.88	0.86	0.80	109	708	2.5	2500	3000	78	733
C3A 315M-b	132	1487	3.310	95.5	95.8	95.4	0.88	0.86	0.80	131	848	2.5	2500	3000	78	733
C3A 315M-c	160	1485	3.972	95.8	95.8	95.3	0.88	0.86	0.80	158	1029	2.7	2500	3000	78	848
C3A 315M-d	200	1486	4.800	96.0	95.9	95.6	0.88	0.86	0.78	198	1285	2.9	2500	3000	78	1026
Serie C3S (carcassa in acciaio) - C3S Series (steel frame)																
C3S 355L-b	250	1488	4.760	96.0	96.0	95.2	0.88	0.86	0.77	247	1604	2.5	2000	2000	84	1480
C3S 355L-c	315	1488	5.752	96	96	95.5	0.88	0.87	0.80	312	2021	2.5	2000	2000	84	1680
C3S 355Lx-a	355	1492	11.657	96	96	95.6	0.89	0.88	0.83	347	2272	2.4	2000	2000	84	1960

I valori di rendimento sono calcolati in accordo con IEC 60034-2-1 con alimentazione sinusoidale.

Efficiency values are given according to IEC 60034-2-1 with sinusoidal supply.

Dati tecnici

ALIMENTAZIONE DA INVERTER

Classe di efficienza IE3 (IEC 60034-30; 2008)

Alta efficienza

Isolamento classe F - Sovratemperatura classe B

Servizio S1 - 690 V - 50 Hz

6 poli - 1.000 giri/min

Technical data

INVERTER SUPPLY

IE3 Efficiency class (IEC 60034-30; 2008)

High Efficiency

Insulation class F - Temperature rise class B

S1 Duty - 690 V - 50 Hz

6 poles - 1.000 rpm

Tipo Type	Potenza Power	Velocità Speed	J	Rendimento Efficiency			Fattore di potenza Power factor cosφ			Corrente Current In (690 V)	Coppia nom. Nom. torque	Coppia Massima Max torque	Velocità max a potenza costante Max speed constant power	Velocità massima Max speed	Rumor. Noise	Forma B3 Mount B3 Peso Weight
	kW	giri/min rpm		kgm ²	100%	75%	50%	100%	75%	50%	A	Nm	Cmax/Cn Tmax/Tn	giri/min rpm	giri/min rpm	dB (A)
Serie C3A (carcasa in alluminio) - C3A Series (aluminium frame)																
C3A 315S	75	988	3.14	94.6	94.4	93.7	0.84	0.78	0.68	79	725	2.3	1600	2800	82	672
C3A 315M-a	90	989	3.63	94.9	94.8	93.7	0.84	0.78	0.68	94	869	2.7	1700	2800	82	730
C3A 315M-b	110	989	4.71	95.1	95	94.4	0.84	0.79	0.69	115	1062	2.8	1700	2800	82	919
C3A 315M-d	132	989	5.69	95.4	95.3	94.9	0.84	0.8	0.721	137	1274	2.9	1700	2800	82	1100
Serie C3S (carcasa in acciaio) - C3S Series (steel frame)																
C3S 355L-a	160	990	6.39	94.8	94.4	93.5	0.84	0.81	0.7	168	1543	2.4	1600	2000	82	1300
C3S 355L-b	200	990	7.98	95.8	95.3	94.7	0.86	0.83	0.75	203	1929	2.4	1600	2000	82	1584
C3S 355L-c	250	990	8.71	95.8	95.6	95	0.86	0.83	0.75	254	2411	2.5	1600	2000	82	1744
C3S 355Lx-a	280	992	11.50	95.8	95.7	95.1	0.83	0.8	0.72	294	2695	1.9	1500	1900	82	1960
C3S 355Lx-b	315	992	13.18	95.8	95.8	95.4	0.83	0.81	0.74	330	3032	1.9	1500	1900	82	2060
C3S 355Lx-c	355	992	14.38	95.8	95.8	95.7	0.83	0.81	0.74	373	3417	2	1500	1900	82	2200

I valori di rendimento sono calcolati in accordo con IEC 60034-2-1 con alimentazione sinusoidale.

Efficiency values are given according to IEC 60034-2-1 with sinusoidal supply.

Dimensioni d'ingombro

Overall dimensions

Le dimensioni d'ingombro sono in accordo con le Norme IEC 60072.
L'uscita d'albero e le dimensioni delle flange di accoppiamento sono realizzate con le seguenti tolleranze:

• Overall dimensions are in accordance with the IEC 60072 Standards.
• The shaft extensions and coupling flange dimensions are designed with the following fits:

Simbolo Symbol	Dimensione Dimension	Tolleranza Tolerance
D - DA	<30	j6
	>30 a 50	k6
	>50	m6
N	<250	j6
	>250	h6
F - FA		h9

Le flange di accoppiamento e i fori delle pulegge per le cinghie devono avere il foro con tolleranza H7.

• Coupling flanges and holes for belt pulleys should have an ISO fit of at least H7.

Nella tabella sono indicate le tolleranze ammesse per le diverse altezze d'asse.

• The deviations specified below are permitted for the dimensions shown in table.

Simbolo Symbol	Dimensione Dimension	Scostamento ammissibile Permitted deviation
H	<250	-0.5
	>280	-1

Dimensioni d'ingombro

Overall dimensions

Forma B3 - Grandezza 63÷160T
Motori autoventilati (IC 411)

Mounting B3 - Frame size 63÷160T
Self-ventilated motors (IC 411)

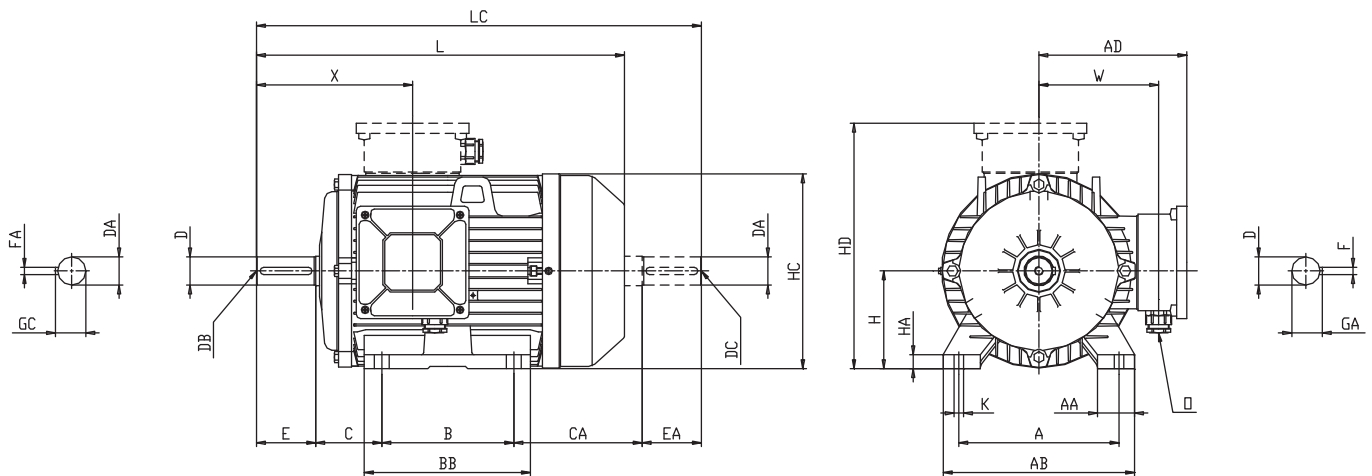

Tipo Type	Poli Poles	Dimensioni / Dimensions																	
		A	AA	AB	AD	B	BB	C	CA	H	HA	HC	HD	K	L	LC	X	W	O
63	2-4-6-8	100	28	128	95	80	103	40	73	63	7	125	158	6	212	239	86	68	M16x1.5
71		112	24	137	115	90	101	45	85.5	71	10	144	186	7	238	280.5	111	88	M20x1.5
80		125	30	155	126	100	122	50	93.5	80	10	164	206	9	274	323.5	113	96	M20x1.5
90S		140	34	175	142	100	125	56	118	90	12	180	232	10	297	374	134	115	M20x1.5
90L		140	34	175	142	125	150	56	118	90	12	180	232	10	322	399	134	115	M20x1.5
100L		160	37	198	155	140	173	63	107	100	14	205	255	12	361	430	160	123	M25x1.5
112MT		190	38	224	155	140	178	70	100	112	15	217	267	12	361	430	160	123	M25x1.5
112M		190	38	228	170	140	172	70	114	112	17	222	282	13	380	444	157	140	M25x1.5
132S		216	50	258	200	140	225	89	167	132	19	264	332	13	470	556	198	162	M25x1.5
132M		216	50	258	200	178	225	89	173	132	19	264	332	13	496	600	198	162	M25x1.5
160MT		254	60	292	215	210	250	108	165	160	18	290	375	14	570	673	275	170	M32x1.5

Tipo Type	Poli Poles	Albero L.A. / DE shaft					Albero L.O.A. / NDE shaft				
		D	E	F	GA	DB	DA	EA	FA	GC	DC
63	2-4-6-8	11 j6	23	4	12.5	M4x0.7	11 j6	23	4	12.5	M4x0.7
71		14 j6	30	5	16	M5x0.8	14 j6	30	5	16	M5x0.8
80		19 j6	40	6	21.5	M6x1	19 j6	40	6	21.5	M6x1
90S		24 j6	50	8	27	M8x1.25	24 j6	50	8	27	M8x1.25
90L		24 j6	50	8	27	M8x1.25	24 j6	50	8	27	M8x1.25
100L		28 j6	60	8	31	M10x1.5	28 j6	60	8	31	M10x1.5
112MT		28 j6	60	8	31	M10x1.5	28 j6	60	8	31	M10x1.5
112M		28 j6	60	8	31	M10x1.5	28 j6	60	8	31	M10x1.5
132S		38 k6	80	10	41	M12x1.75	38 k6	80	10	41	M12x1.75
132M		38 k6	80	10	41	M12x1.75	38 k6	80	10	41	M12x1.75
160MT		42 k6	110	12	45	M16x2	38 k6	80	10	41	M12x1.75

Dimensioni d'ingombro

Forma B3 - Grandezza 160÷200
Motori autoventilati (IC 411)

Overall dimensions

Mounting B3 - Frame size 160÷200
Self-ventilated motors (IC 411)

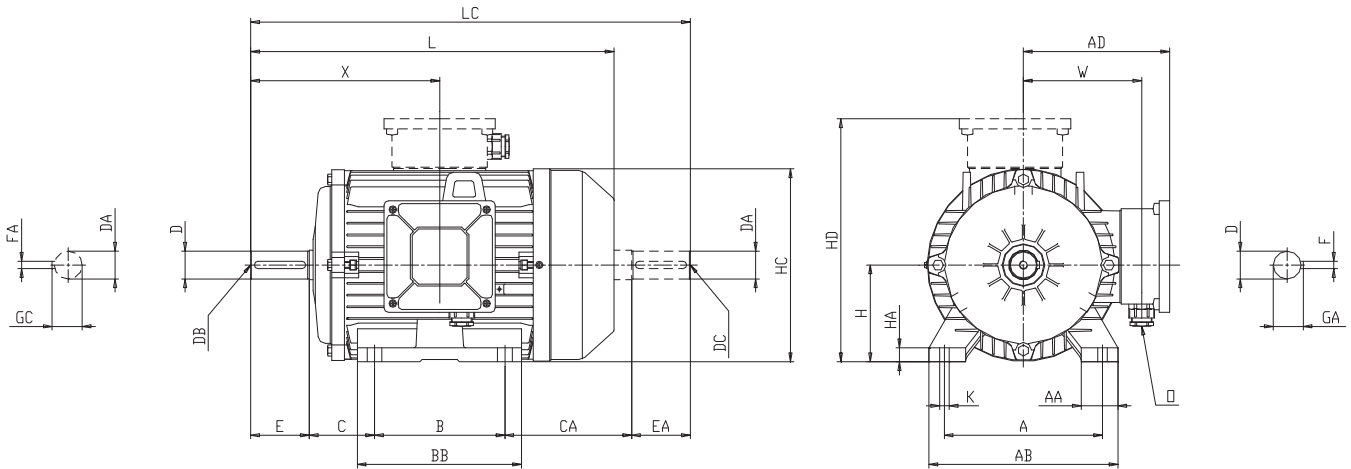

Tipo Type	Poli Poles	Dimensioni / Dimensions																	
		A	AA	AB	AD	B	BB	C	CA	H	HA	HC	HD	K	L	LC	X	W	O
160M	2-4-6-8	254	67	315	245	210	332	108	227	160	20	325	405	14	650	765	345	195	M40x1.5
160L		254	67	315	245	254	332	108	183	160	20	325	405	14	650	765	345	195	M40x1.5
180MT		279	80	350	245	241	320	121	242	180	22	340	425	14	690	824	370	195	M40x1.5
180LT		279	80	350	245	279	320	121	204	180	22	340	425	14	690	824	370	195	M40x1.5
180L		279	80	350	275	279	320	121	226	180	22	360	450	14	725	846	370	221	M40x1.5
200LT		318	90	395	275	305	365	133	247	200	24	380	475	18	750	905	400	215	M40x1.5
200L		318	90	395	315	305	365	133	247	200	24	405	505	18	780	905	400	255	M50x1.5

Tipo Type	Poli Poles	Albero L.A. / DE shaft					Albero L.O.A. / NDE shaft				
		D	E	F	GA	DB	DA	EA	FA	GC	DC
160M	2-4-6-8	42 k6	110	12	45	M16x2	42 k6	110	12	45	M16x2
160L		42 k6	110	12	45	M16x2	42 k6	110	12	45	M16x2
180MT		48 k6	110	14	51.5	M16x2	48 k6	110	14	51.5	M16x2
180LT		48 k6	110	14	51.5	M16x2	48 k6	110	14	51.5	M16x2
180L		48 k6	110	14	51.5	M16x2	48 k6	110	14	51.5	M16x2
200LT		55 m6	110	16	59	M20x2.5	55 m6	110	16	59	M20x2.5
200L		55 m6	110	16	59	M20x2.5	55 M6	110	16	59	M20x2.5

Dimensioni d'ingombro

Overall dimensions

Forma B3 - Grandezza 225T÷280T
Motori autoventilati (IC 411)

Mounting B3 - Frame size 225T÷280T
Self-ventilated motors (IC 411)

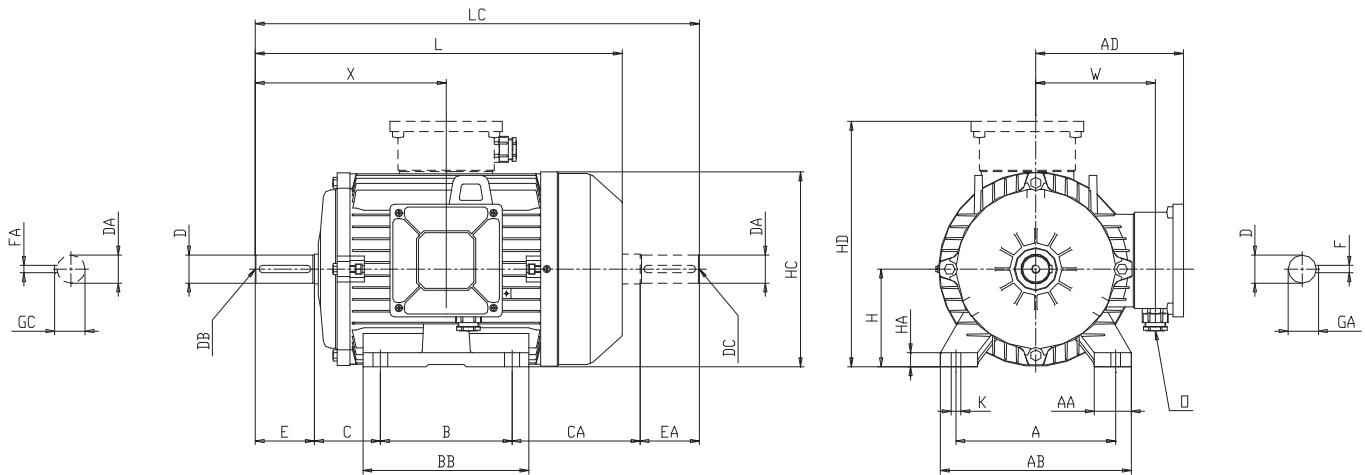

Tipo Type	Poli Poles	Dimensioni / Dimensions																	
		A	AA	AB	AD	B	BB	C	CA	H	HA	HC	HD	K	L	LC	X	W	O
225ST	4-6-8	356	80	436	315	286	370	149	270	225	30	420	515	18	830	985	445	245	M50x1.5
225MT	2	356	80	436	315	311	370	149	245	225	30	420	515	18	800	925	415	245	M50x1.5
	4-6-8	356	80	436	315	311	370	149	245	225	30	420	515	18	830	985	445	245	M50x1.5
225M	2	356	80	436	335	311	370	149	285	225	30	450	560	18	840	965	415	280	M50x1.5
	4-6-8	356	80	436	335	311	370	149	285	225	30	450	560	18	870	1025	445	280	M50x1.5
250MT	2	406	95	476	330	349	410	168	264	250	32	480	580	22	905	1061	485	270	M50x1.5
	4-6-8	406	95	476	330	349	410	168	264	250	32	480	580	22	905	1061	485	270	M50x1.5
280ST	2	457	115	534	400	368	480	190	332	280	35	535	680	22	1030	1170	540	320	M50x1.5
	4-6-8	457	115	534	400	368	480	190	332	280	35	535	680	22	1030	1170	540	320	M50x1.5
280MT	2	457	115	534	400	419	480	190	281	280	35	535	680	22	1030	1170	540	320	M50x1.5
	4-6-8	457	115	534	400	419	480	190	281	280	35	535	680	22	1030	1170	540	320	M50x1.5

Tipo Type	Poli Poles	Albero L.A. / DE shaft					Albero L.O.A. / NDE shaft				
		D	E	F	GA	DB	DA	EA	FA	GC	DC
225ST	4-6-8	60 m6	140	18	64	M20x2.5	60 m6	140	18	64	M20x2.5
225MT	2	55 m6	110	16	59	M20x2.5	55 m6	110	16	59	M20x2.5
	4-6-8	60 m6	140	18	64	M20x2.5	60 m6	140	18	64	M20x2.5
225M	2	55 m6	110	16	59	M20x2.5	55 m6	110	16	59	M20x2.5
	4-6-8	60 m6	140	18	64	M20x2.5	60 m6	140	18	64	M20x2.5
250MT	2	60 m6	140	18	64	M20x2.5	60 m6	140	18	64	M20x2.5
	4-6-8	65 m6	140	18	69	M20x2.5	65 m6	140	18	69	M20x2.5
280ST	2	65 m6	140	18	69	M20x2.5	65 m6	140	18	69	M20x2.5
	4-6-8	75 m6	140	20	79.5	M20x2.5	75 m6	140	20	79.5	M20x2.5
280MT	2	65 m6	140	18	69	M20x2.5	65 m6	140	18	69	M20x2.5
	4-6-8	75 m6	140	20	79.5	M20x2.5	75 m6	140	20	79.5	M20x2.5

Dimensioni d'ingombro

Forma B3 - Grandezza 315T÷355T
Motori autoventilati (IC 411)

Overall dimensions

Mounting B3 - Frame size 315T÷355T
Self-ventilated motors (IC 411)

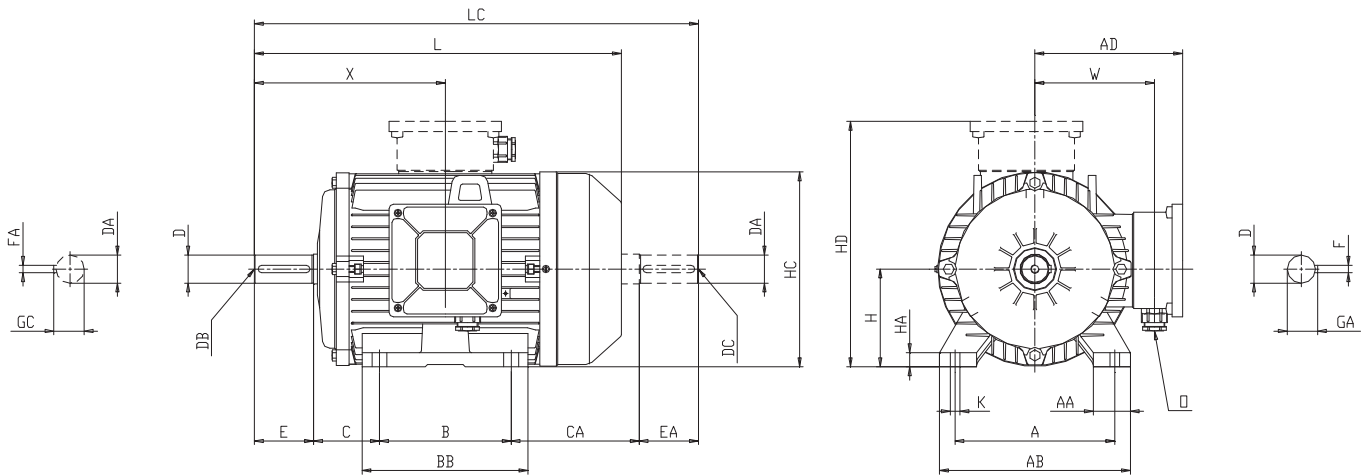

Tipo Type	Poli Poles	Dimensioni / Dimensions																	
		A	AA	AB	AD	B	BB	C	CA	H	HA	HC	HD	K	L	LC	X	W	O
315ST	2	508	130	576	400	406	480	216	293	315	38	575	715	27	1050	1195	560	320	M63x1.5
	4-6-8	508	130	576	400	406	480	216	293	315	38	575	715	27	1080	1255	590	320	M63x1.5
315M a-b-c-d	2	508	135	600	470	457	545	216	352	315	42	620	785	27	1150	1305	582	390	N.2 M63x1.5
	4-6-8								1180						1365	612			
315M e-f-g	2	508	135	600	470	457	545	216	352	315	42	620	785	27	1150	1305	582	390	N.2 M63x1.5
	4-6-8								457						1470	612			
355LT	2	610	165	710	470	630	715	254	390	355	50	660	825	27	1375	1554	710	390	N.2 M63x1.5
	4-6-8	610	165	710	470	630	715	254	390	355	50	660	825	27	1445	1654	780	390	N.2 M63x1.5

Tipo Type	Poli Poles	Albero L.A. / DE shaft					Albero L.O.A. / NDE shaft				
		D	E	F	GA	DB	DA	EA	FA	GC	DC
315ST	2	65 m6	140	18	69	M20x2.5	65 m6	140	18	69	M20x2.5
	4-6-8	80 m6	170	22	85	M20x2.5	80 m6	170	22	85	M20x2.5
315M a-b-c-d- e-f-g	2	65 m6	140	18	69	M20x2.5	65 m6	140	18	69	M20x2.5
	4-6-8	80 m6	170	22	85	M20x2.5	80 m6	170	22	85	M20x2.5
355LT	2	75 m6	140	20	79.5	M20x2.5	75 m6	140	20	79.5	M20x2.5
	4-6-8	100 m6	210	28	106	M24x3	90 m6	170	25	95	M24x3

Dimensioni d'ingombro

Forma B3 - Grandezza 355L÷355Lx
Motori autoventilati (IC 411)

Overall dimensions

Mounting B3 - Frame size 355L÷355Lx
Self-ventilated motors (IC 411)

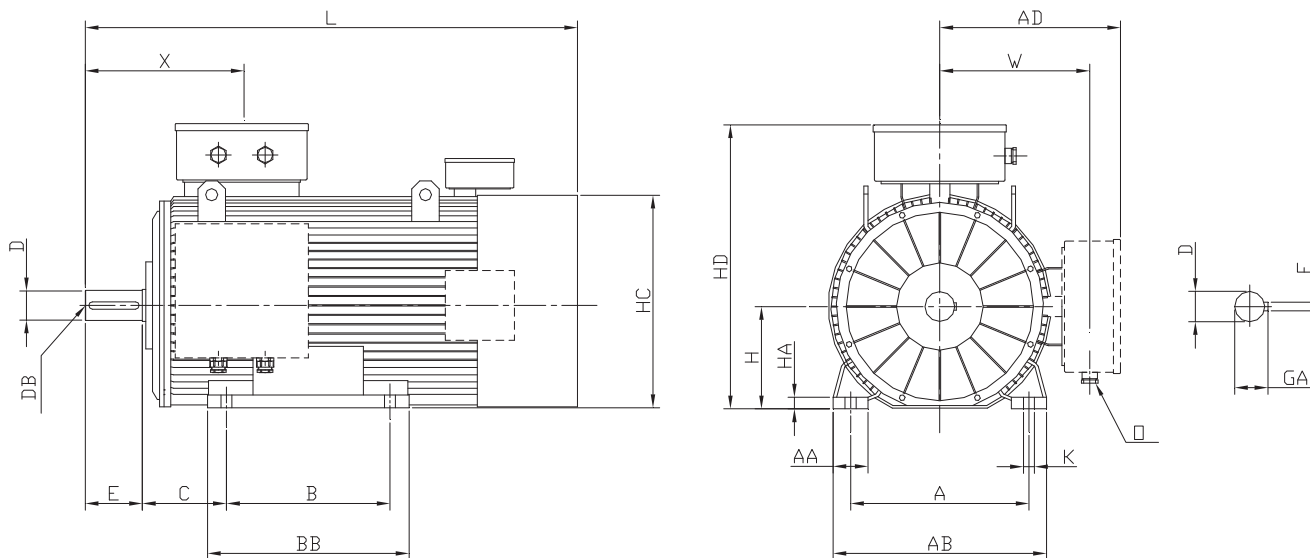

Tipo Type	Poli Poles	Dimensioni / Dimensions															
		A	AA	AB	AD	B	BB	C	H	HA	HC	HD	K	L	X	W	O
355L a-b-c	2	610	120	730	545	630	700	254	355	35	690	900	27	1470	495	450	N.2 M63x1.5
	4-6-8															1540	565
355Lx a-b-c-d	4-6-8	610	120	730	615	630	700	254	355	35	750	970	27	1770	570	515	N.2 M63x1.5

Tipo Type	Poli Poles	Albero L.A. / DE shaft				
		D	E	F	GA	DB
355L a-b-c	2	75 m6	140	20	79.5	M20x2.5
	4-6-8	100 m6	210	28	106	M24x3
355Lx a-b-c-d	4-6-8	100 m6	210	28	106	M24x3

Dimensioni d'ingombro

Forma B3 - Grandezza 400Lx÷500Lx
Motori autoventilati (IC 411)

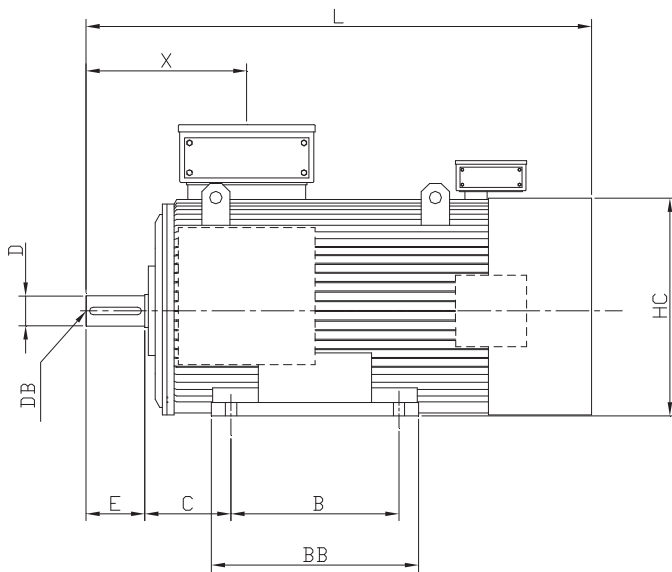

Overall dimensions

Mounting B3 - Frame size 400Lx÷500Lx
Self-ventilated motors (IC 411)

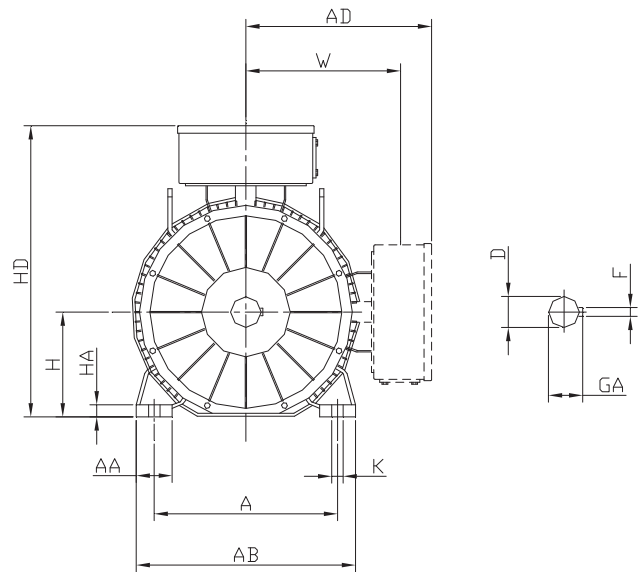

Tipo Type	Poli Poles	Dimensioni / Dimensions												
		A	AA	AB	AD	B	BB	C	H	HA	HC	HD	K	L
400Lxa	4-6-8	686	120	806	720 ⁽¹⁾	710	790	280	400	40	850	1120 ⁽¹⁾	33	1950
400Lxb					860 ⁽²⁾							1260 ⁽²⁾		2050
400Lxc					770 ⁽¹⁾							910 ⁽²⁾		1220 ⁽¹⁾
450Lxa		750	120	900	770 ⁽¹⁾	800	1000	315	450	45	938	1220 ⁽¹⁾	33	2100
450Lxb					910 ⁽²⁾							1360 ⁽²⁾		2200
500Lxa		850	150	950	830 ⁽¹⁾	900	1000	335	500	45	1035	1330 ⁽¹⁾	35	2260
500Lxb					970 ⁽²⁾							1470 ⁽²⁾		2360
500Lxc					830 ⁽¹⁾							970 ⁽²⁾		1330 ⁽¹⁾

(1) Motore fornito con N.3 morsetti
(2) Motore fornito con N.6 morsetti

(1) Motor supplied with No.3 terminals
(2) Motor supplied with No.6 terminals

Tipo Type	Poli Poles	Albero L.A. / DE shaft				
		D	E	F	GA	DB
400Lxa	4-6-8	110 m6	210	28	116	-
400Lxb						
400Lxc						
450Lxa	4-6-8	110 m6	210	28	116	-
450Lxb						
500Lxa	4-6-8	130 m6	250	32	137	-
500Lxb						
500Lxc						

Dimensioni d'ingombro

Forma B5 - Grandezza 63÷160T
 Forma V1 - Grandezza 63÷160T
 Motori autoventilati (IC 411)

Overall dimensions

Mounting B5 - Frame size 63÷160T
 Mounting V1 - Frame size 63÷160T
 Self-ventilated motors (IC 411)

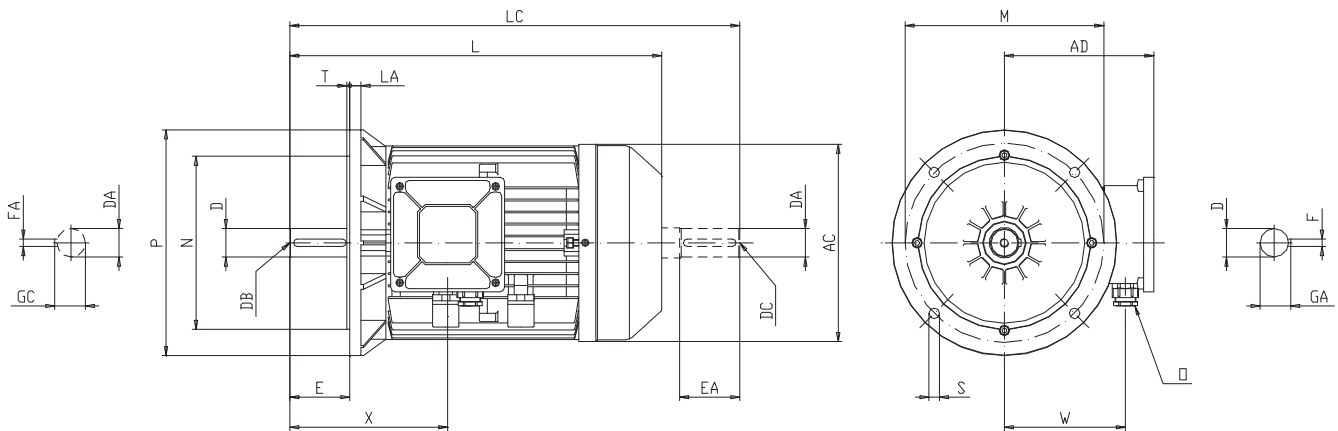

Tipo Type	Poli Poles	Dimensioni / Dimensions												
		AC	AD	L	LA	LC	M	N	P	S	T	X	W	O
63	2-4-6-8	125	95	212	10	239	115	95 j6	140	N.4 x 9.5	3	86	68	M16x1.5
71		148	115	238	10	280.5	130	110 j6	160	N.4 x 9.5	3.5	111	88	M20x1.5
80		170	126	274	12	323.5	165	130 j6	200	N.4 x 11.5	3.5	113	96	M20x1.5
90S		185	142	297	12	374	165	130 j6	200	N.4 x 11.5	3.5	134	115	M20x1.5
90L		185	142	322	12	399	165	130 j6	200	N.4 x 11.5	3.5	134	115	M20x1.5
100L		210	155	361	14	430	215	180 j6	250	N.4 x 14	4	160	123	M25x1.5
112MT		210	155	361	14	430	215	180 j6	250	N.4 x 14	4	160	123	M25x1.5
112M		225	166	380	14	444	215	180 j6	250	N.4 x 14	4	157	140	M25x1.5
132S		260	200	470	14	556	265	230 j6	300	N.4 x 14	4	198	162	M25x1.5
132M		260	200	496	14	600	265	230 j6	300	N.4 x 14	4	198	162	M25x1.5
160MT		260	215	570	15	673	300	250 h6	350	N.4 x 18	5	275	170	M32x1.5

Tipo Type	Poli Poles	Dimensioni / Dimensions									
		D	E	F	GA	DB	DA	EA	FA	GC	DC
63	2-4-6-8	11 j6	23	4	12.5	M4x0.7	11 j6	23	4	12.5	M4x0.7
71		14 j6	30	5	16	M5x0.8	14 j6	30	5	16	M5x0.8
80		19 j6	40	6	21.5	M6x1	19 j6	40	6	21.5	M6x1
90S		24 j6	50	8	27	M8x1.25	24 j6	50	8	27	M8x1.25
90L		24 j6	50	8	27	M8x1.25	24 j6	50	8	27	M8x1.25
100L		28 j6	60	8	31	M10x1.5	28 j6	60	8	31	M10x1.5
112MT		28 j6	60	8	31	M10x1.5	28 j6	60	8	31	M10x1.5
112M		28 j6	60	8	31	M10x1.5	28 j6	60	8	31	M10x1.5
132S		38 k6	80	10	41	M12x1.75	38 k6	80	10	41	M12x1.75
132M		38 k6	80	10	41	M12x1.75	38 k6	80	10	41	M12x1.75
160MT		42 k6	110	12	45	M16x2	38 k6	80	10	41	M12x1.75

Dimensioni d'ingombro

Forma B5 - Grandezza 160÷200
 Forma V1 - Grandezza 160÷200
 Motori autoventilati (IC 411)

Overall dimensions

Mounting B5 - Frame size 160÷200
 Mounting V1 - Frame size 160÷200
 Self-ventilated motors (IC 411)

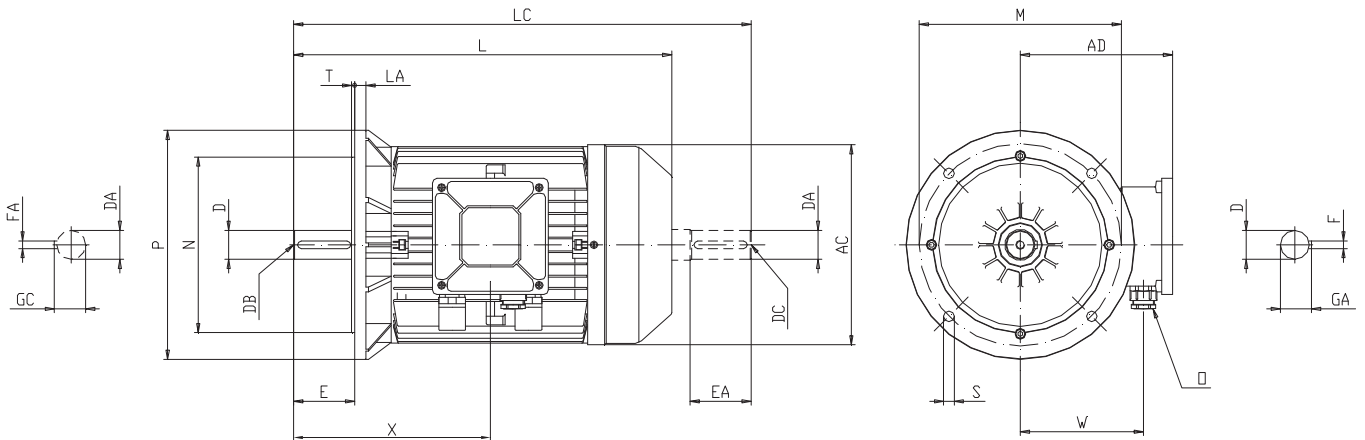

Tipo Type	Poli Poles	Dimensioni / Dimensions												
		AC	AD	L	LA	LC	M	N	P	S	T	X	W	O
160M	2-4-6-8	320	245	650	15	765	300	250 h6	350	N.4 x 18	5	345	195	M40x1.5
160L		320	245	650	15	765	300	250 h6	350	N.4 x 18	5	345	195	M40x1.5
180MT		320	245	690	15	824	300	250 h6	350	N.4 x 18	5	370	195	M40x1.5
180LT		320	245	690	15	824	300	250 h6	350	N.4 x 18	5	370	195	M40x1.5
180L		360	275	725	15	846	300	250 h6	350	N.4 x 18	5	370	221	M40x1.5
200LT		360	275	750	15	905	350	300 h6	400	N.4 x 18	5	400	215	M40x1.5
200L		395	315	780	15	905	350	300 h6	400	N.4 x 18	5	400	255	M40x1.5

Tipo Type	Poli Poles	Albero L.A. / DE shaft					Albero L.O.A. / NDE shaft				
		D	E	F	GA	DB	DA	EA	FA	GC	DC
160M	2-4-6-8	42 k6	110	12	45	M16x2	42 k6	110	12	45	M16x2
160L		42 k6	110	12	45	M16x2	42 k6	110	12	45	M16x2
180MT		48 k6	110	14	51.5	M16x2	48 k6	110	14	51.5	M16x2
180LT		48 k6	110	14	51.5	M16x2	48 k6	110	14	51.5	M16x2
180L		48 k6	110	14	51.5	M16x2	48 k6	110	14	51.5	M16x2
200LT		55 m6	110	16	59	M20x2.5	55 m6	110	16	59	M20x2.5
200L		55 m6	110	16	59	M20x2.5	55 m6	110	16	59	M20x2.5

Dimensioni d'ingombro

Forma B5 - Grandezza 225T÷280T
 Forma V1 - Grandezza 225T÷280T
 Motori autoventilati (IC 411)

Overall dimensions

Mounting B5 - Frame size 225T÷280T
 Mounting V1 - Frame size 225T÷280T
 Self-ventilated motors (IC 411)

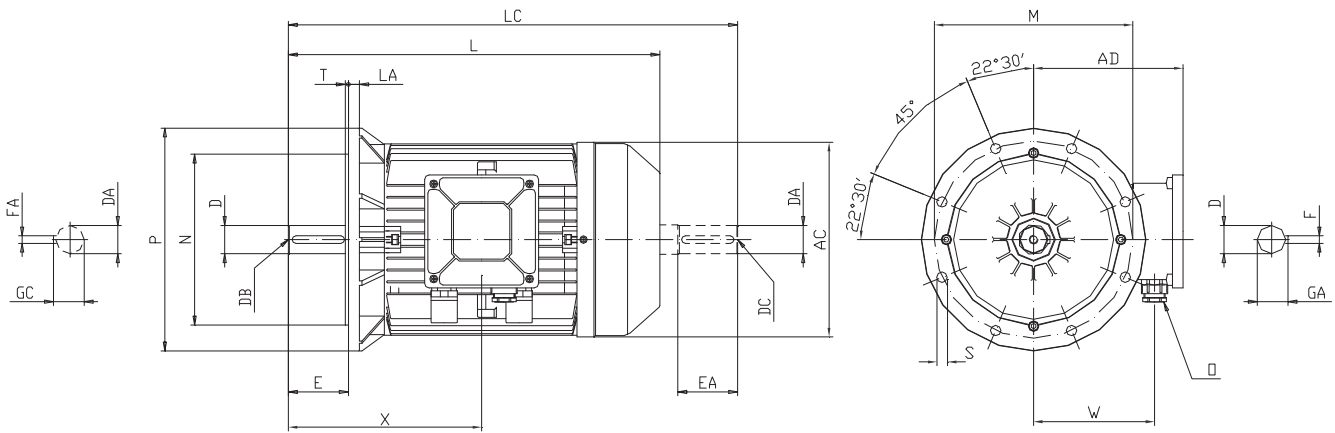

Tipo Type	Poli Poles	Dimensioni / Dimensions												
		AC	AD	L	LA	LC	M	N	P	S	T	X	W	O
225ST	4-6-8	400	315	830	16	985	400	350 h6	450	N.8 x 18	5	445	245	M50x1.5
225MT	2	400	315	800	16	925	400	350 h6	450	N.8 x 18	5	415	245	M50x1.5
	4-6-8	400	315	830	16	985	400	350 h6	450	N.8 x 18	5	445	245	M50x1.5
225M	2	450	335	840	16	965	400	350 h6	450	N.8 x 18	5	415	280	M50x1.5
	4-6-8	450	335	870	16	1025	400	350 h6	450	N.8 x 18	5	445	280	M50x1.5
250MT	2	450	330	905	18	1061	500	450 h6	550	N.8 x 18	5	485	270	M50x1.5
	4-6-8	450	330	905	18	1061	500	450 h6	550	N.8 x 18	5	485	270	M50x1.5
280ST	2	510	400	1030	18	1170	500	450 h6	550	N.8 x 18	5	540	320	M50x1.5
	4-6-8	510	400	1030	18	1170	500	450 h6	550	N.8 x 18	5	540	320	M50x1.5
280MT	2	510	400	1030	18	1170	500	450 h6	550	N.8 x 18	5	540	320	M50x1.5
	4-6-8	510	400	1030	18	1170	500	450 h6	550	N.8 x 18	5	540	320	M50x1.5

Tipo Type	Poli Poles	Albero L.A. / DE shaft					Albero L.O.A. / NDE shaft				
		D	E	F	GA	DB	DA	EA	FA	GC	DC
225ST	4-6-8	60 m6	140	18	64	M20x2.5	60 m6	140	18	64	M20x2.5
225MT	2	55 m6	110	16	59	M20x2.5	55 m6	110	16	59	M20x2.5
	4-6-8	60 m6	140	18	64	M20x2.5	60 m6	140	18	64	M20x2.5
225M	2	55 m6	110	16	59	M20x2.5	55 m6	110	16	59	M20x2.5
	4-6-8	60 m6	140	18	64	M20x2.5	60 m6	140	18	64	M20x2.5
250MT	2	60 m6	140	18	64	M20x2.5	60 m6	140	18	64	M20x2.5
	4-6-8	65 m6	140	18	69	M20x2.5	65 m6	140	18	69	M20x2.5
280ST	2	65 m6	140	18	69	M20x2.5	65 m6	140	18	69	M20x2.5
	4-6-8	75 m6	140	20	79.5	M20x2.5	75 m6	140	20	79.5	M20x2.5
280MT	2	65 m6	140	18	69	M20x2.5	65 m6	140	18	69	M20x2.5
	4-6-8	75 m6	140	20	79.5	M20x2.5	75 m6	140	20	79.5	M20x2.5

Dimensioni d'ingombro

Forma B5 - Grandezza 315T÷355T
 Forma V1 - Grandezza 315T÷355T
 Motori autoventilati (IC 411)

Overall dimensions

Mounting B5 - Frame size 315T÷355T
 Mounting V1 - Frame size 315T÷355T
 Self-ventilated motors (IC 411)

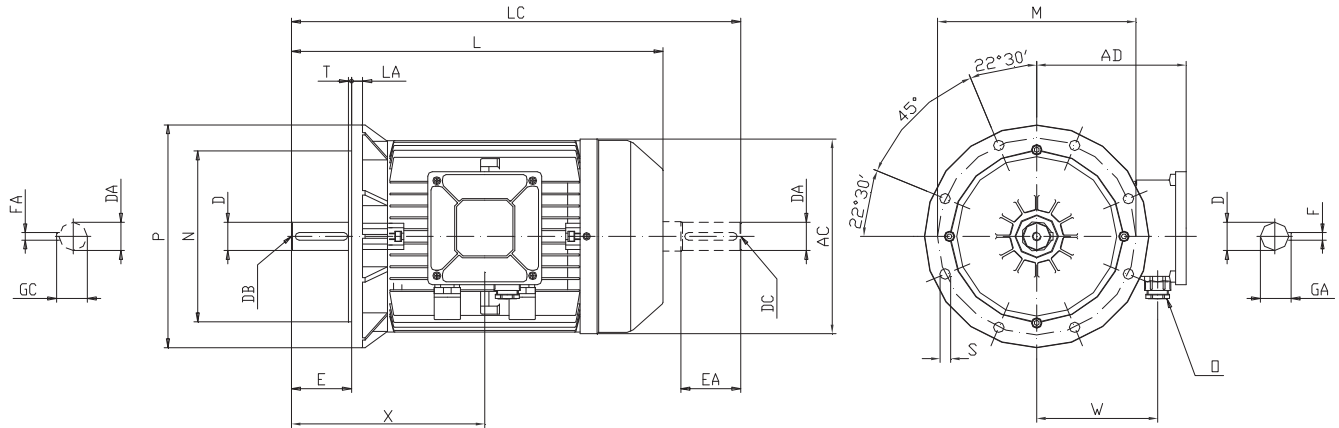

Tipo Type	Poli Poles	Dimensioni / Dimensions												
		AC	AD	L	LA	LC	M	N	P	S	T	X	W	O
315ST	2	520	400	1050	22	1195	600	550 h6	660	N.8 x 22	6	560	320	M63x1.5
	4-6-8	520	400	1080	22	1255	600	550 h6	660	N.8 x 22	6	590	320	M63x1.5
315M a-b-c-d	2	610	470	1150	22	1305	600	550 h6	660	N.8 x 22	6	582	390	N.2 M63x1.5
	4-6-8			1180		1365						612		
315Mb e-f-g	2			1150		1305						582		
	4-6-8			1280		1470						612		
355LT	2	610	470	1375	25	1554	740	680 h6	800	N.8 x 22	6	710	390	N.2 M63x1.5
	4-6-8	610	470	1445	25	1654	740	680 h6	800	N.8 x 22	6	780	390	N.2 M63x1.5

Tipo Type	Poli Poles	Albero L.A. / DE shaft					Albero L.O.A. / NDE shaft				
		D	E	F	GA	DB	DA	EA	FA	GC	DC
315ST	2	65 m6	140	18	69	M20x2.5	65 m6	140	18	69	M20x2.5
	4-6-8	80 m6	170	22	85	M20x2.5	80 m6	170	22	85	M20x2.5
315M a-b-c-d-e- f-g	2	65 m6	140	18	69	M20x2.5	65 m6	140	18	69	M20x2.5
	4-6-8	80 m6	170	22	85	M20x2.5	80 m6	170	22	85	M20x2.5
355LT	2	75 m6	140	20	79.5	M20x2.5	75 m6	140	20	79.5	M20x2.5
	4-6-8	100 m6	210	28	106	M24x3	90 m6	170	25	95	M24x3

Dimensioni d'ingombro

Forma V1 - Grandezza 355L÷355Lx
Motori autoventilati (IC 411)

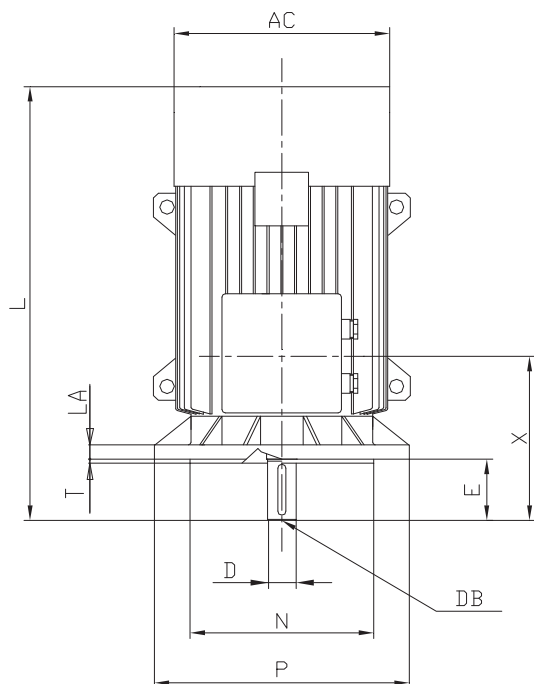

Overall dimensions

Mounting V1 - Frame size 355L÷355Lx
Self-ventilated motors (IC 411)

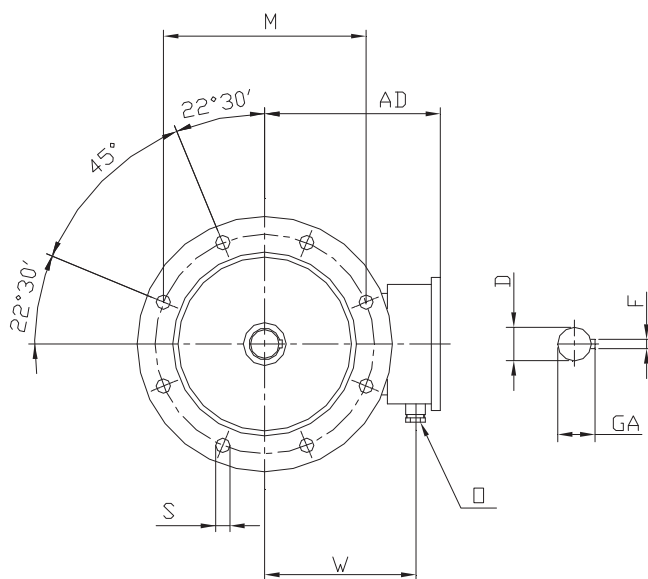

Tipo Type	Poli Poles	Dimensioni / Dimensions											
		AC	AD	L	LA	M	N	P	S	T	X	W	O
355L a-b-c	2	710	545	1470	25	740	680 h6	800	N.8 x 22	6	495	450	N.2 M63x1.5
	1540			565									
355Lx a-b-c-d	4-6-8	796	615	1770	25	740	680 h6	800	N.8 x 22	6	570	515	N.2 M63x1.5

Tipo Type	Poli Poles	Dimensioni / Dimensions				
		D	E	F	GA	DB
355L a-b-c	2	75 m6	140	20	79.5	M20x2.5
	4-6-8	100 m6	210	28	106	M24x3
355Lx a-b-c-d	4-6-8	100 m6	210	28	106	M24x3

Dimensioni d'ingombro

Forma V1 - Grandezza 400Lx÷500Lx
Motori autoventilati (IC 411)

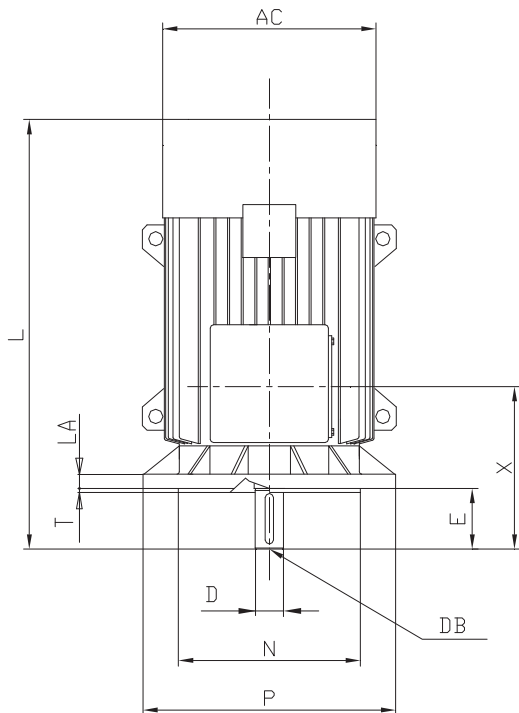

Overall dimensions

Mounting V1 - Frame size 400Lx÷500Lx
Self-ventilated motors (IC 411)

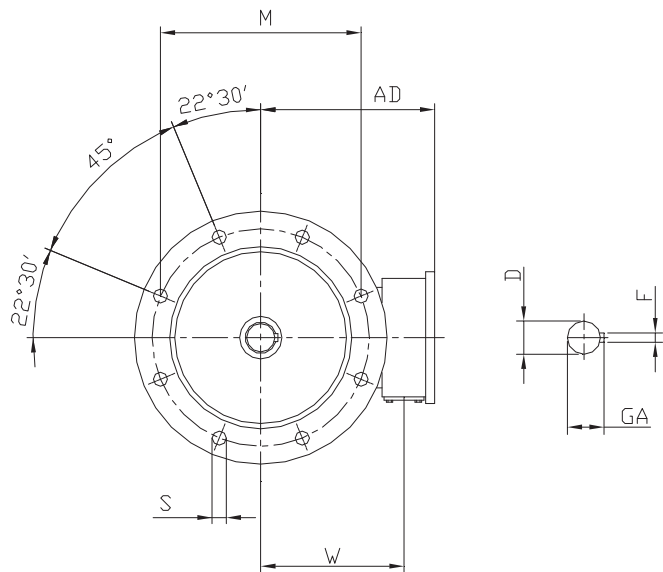

Tipo Type	Poli Poles	Dimensioni / Dimensions									
		AC	AD	L	LA	LC	M	N	P	S	
400Lxa	4-6-8	880		1950	28	940	880 h6	1000	N.8 x 28	6	
400Lxb			720 ⁽¹⁾	2050							
400Lxc			860 ⁽²⁾	2050							
450Lxa		975		2100	28	940	880 h6	1000	N.8 x 28	6	
450Lxb				770 ⁽¹⁾							2200
500Lxa		1075		2260	28	940	880 h6	1000	N.8 x 28	6	
500Lxb				830 ⁽¹⁾							2360
500Lxc				970 ⁽²⁾							2360

(1) Motore fornito con N.3 morsetti
(2) Motore fornito con N.6 morsetti

(1) Motor supplied with No.3 terminals
(2) Motor supplied with No.6 terminals

Tipo Type	Poli Poles	Albero L.A. / DE shaft				
		D	E	F	GA	DB
400Lxa	4-6-8	110 m6	210	28	116	-
400Lxb						
400Lxc						
450Lxa	4-6-8	110 m6	210	28	116	-
450Lxb						
500Lxa	4-6-8	130 m6	250	32	137	-

Dimensioni d'ingombro

Overall dimensions

Forma B3/B5 - Grandezza 63÷160T
Motori autoventilati (IC 411)

Mounting B3/B5 - Frame size 63÷160T
Self-ventilated motors (IC 411)

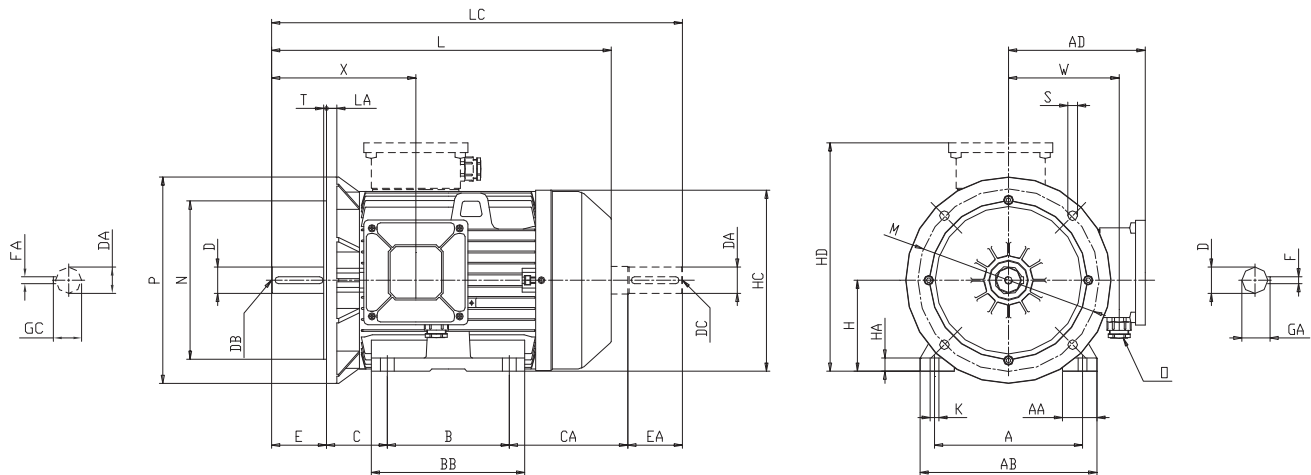

Tipo Type	Poli Poles	Dimensioni / Dimensions																	
		A	AA	AB	AD	B	BB	C	CA	H	HA	HC	HD	K	L	LC	X	W	O
63	2-4-6-8	100	28	128	95	80	103	40	73	63	7	125	158	6	212	239	86	68	M16x1.5
71		112	24	137	115	90	101	45	85.5	71	10	144	186	7	238	280.5	111	88	M20x1.5
80		125	30	155	126	100	122	50	93.5	80	10	164	206	9	274	323.5	113	96	M20x1.5
90S		140	34	175	142	100	125	56	118	90	12	180	232	10	297	374	134	115	M20x1.5
90L		140	34	175	142	125	150	56	118	90	12	180	232	10	322	399	134	115	M20x1.5
100L		160	37	198	155	140	173	63	107	100	14	205	255	12	361	430	160	123	M25x1.5
112MT		190	38	224	155	140	178	70	100	112	15	217	267	12	361	430	160	123	M25x1.5
112M		190	38	228	170	140	172	70	114	112	17	222	282	13	380	444	157	140	M25x1.5
132S		216	50	258	200	140	225	89	167	132	19	264	332	13	470	556	198	162	M25x1.5
132M		216	50	258	200	178	225	89	173	132	19	264	332	13	496	600	198	162	M25x1.5
160MT		254	60	292	215	210	250	108	165	160	18	290	375	14	570	673	275	170	M32x1.5

Tipo Type	Poli Poles	Flangia B5 / Flange B5						Albero L.A. / DE shaft					Albero L.O.A. / NDE shaft					
		LA	M	N	P	S	T	D	E	F	GA	DB	DA	EA	FA	GC	DC	
63	2-4-6-8	10	115	95 j6	140	N.4 x 9.5	3	11 j6	23	4	12.5	M4x0.7	11 j6	23	4	12.5	M4x0.7	
71		10	130	110 j6	160	N.4 x 9.5	3.5	14 j6	30	5	16	M5x0.8	14 j6	30	5	16	M5x0.8	
80		12	165	130 j6	200	N.4 x 11.5	3.5	19 j6	40	6	21.5	M6x1	19 j6	40	6	21.5	M6x1	
90S		12	165	130 j6	200	N.4 x 11.5	3.5	24 j6	50	8	27	M8x1.25	24 j6	50	8	27	M8x1.25	
90L		12	165	130 j6	200	N.4 x 11.5	3.5	24 j6	50	8	27	M8x1.25	24 j6	50	8	27	M8x1.25	
100L		14	215	180 j6	250	N.4 x 14	4	28 j6	60	8	31	M10x1.5	28 j6	60	8	31	M10x1.5	
112MT		14	215	180 j6	250	N.4 x 14	4	28 j6	60	8	31	M10x1.5	28 j6	60	8	31	M10x1.5	
112M		14	215	180 j6	250	N.4 x 14	4	28 j6	60	8	31	M10x1.5	28 j6	60	8	31	M10x1.5	
132S		14	265	230 j6	300	N.4 x 14	4	38 k6	80	10	41	M12x1.75	38 k6	80	10	41	M12x1.75	
132M		14	265	230 j6	300	N.4 x 14	4	38 k6	80	10	41	M12x1.75	38 k6	80	10	41	M12x1.75	
160MT		15	300	250 h6	350	N.4 x 18	5	42 k6	110	12	45	M16x2	38 k6	80	10	41	M12x1.75	

Dimensioni d'ingombro

Forma B3/B5 - Grandezza 160÷200
Motori autoventilati (IC 411)

Overall dimensions

Mounting B3/B5 - Frame size 160÷200
Self-ventilated motors (IC 411)

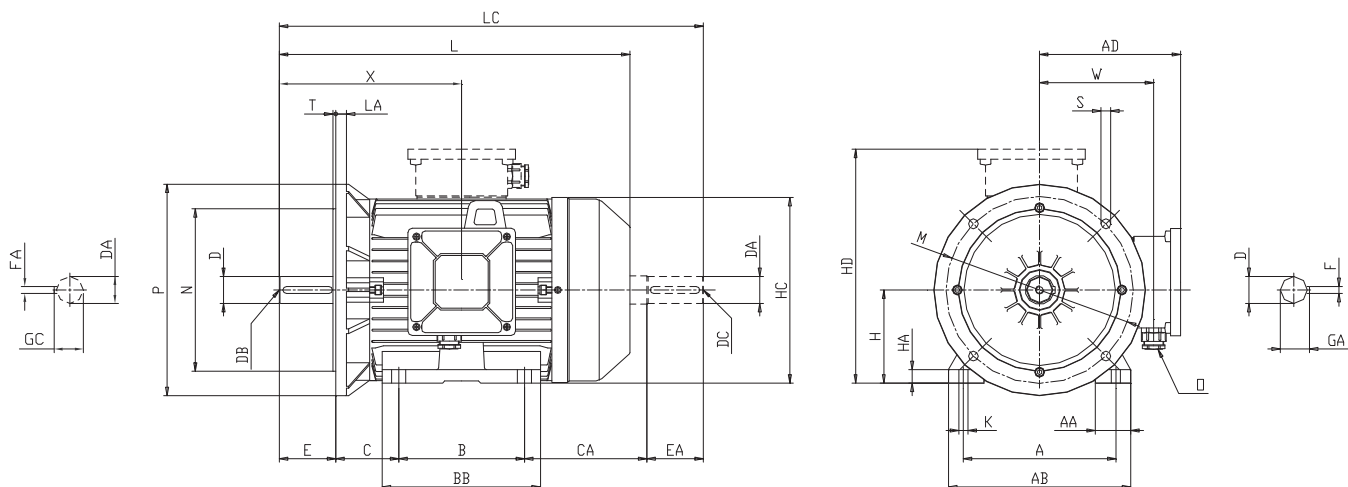

Tipo Type	Poli Poles	Dimensioni / Dimensions																	
		A	AA	AB	AD	B	BB	C	CA	H	HA	HC	HD	K	L	LC	X	W	O
160M	2-4-6-8	254	67	315	245	210	332	108	227	160	20	325	405	14	650	765	345	195	M40x1.5
160L		254	67	315	245	254	332	108	183	160	20	325	405	14	650	765	345	195	M40x1.5
180MT		279	80	350	245	241	320	121	242	180	22	340	425	14	690	824	370	195	M40x1.5
180LT		279	80	350	245	279	320	121	204	180	22	340	425	14	690	824	370	195	M40x1.5
180L		279	80	350	275	279	320	121	226	180	22	360	450	14	725	846	370	221	M40x1.5
200LT		318	90	395	275	305	365	133	247	200	24	380	475	18	750	905	400	215	M40x1.5
200L		318	90	395	315	305	365	133	247	200	24	405	505	18	780	905	400	255	M50x1.5

Tipo Type	Poli Poles	Flangia B5 / Flange B5						Albero L.A. / DE shaft						Albero L.O.A. / NDE shaft					
		LA	M	N	P	S	T	D	E	F	GA	DB	DA	EA	FA	GC	DC		
160M	2-4-6-8	15	300	250 h6	350	N.4 x 18	5	42 k6	110	12	45	M16x2	42 k6	110	12	45	M16x2		
160L		15	300	250 h6	350	N.4 x 18	5	42 k6	110	12	45	M16x2	42 k6	110	12	45	M16x2		
180MT		15	300	250 h6	350	N.4 x 18	5	48 k6	110	14	51.5	M16x2	48 k6	110	14	51.5	M16x2		
180LT		15	300	250 h6	350	N.4 x 18	5	48 k6	110	14	51.5	M16x2	48 k6	110	14	51.5	M16x2		
180L		15	300	250 h6	350	N.4 x 18	5	48 k6	110	14	51.5	M16x2	48 k6	110	14	51.5	M16x2		
200LT		15	350	300 h6	400	N.4 x 18	5	55 m6	110	16	59	M20x2.5	55 m6	110	16	59	M20x2.5		
200L		15	350	300 h6	400	N.4 x 18	5	55 m6	110	16	59	M20x2.5	55 m6	110	16	59	M20x2.5		

Dimensioni d'ingombro

Overall dimensions

Forma B3/B5 - Grandezza 225T÷280T
Motori autoventilati (IC 411)

Mounting B3/B5 - Frame size 225T÷280T
Self-ventilated motors (IC 411)

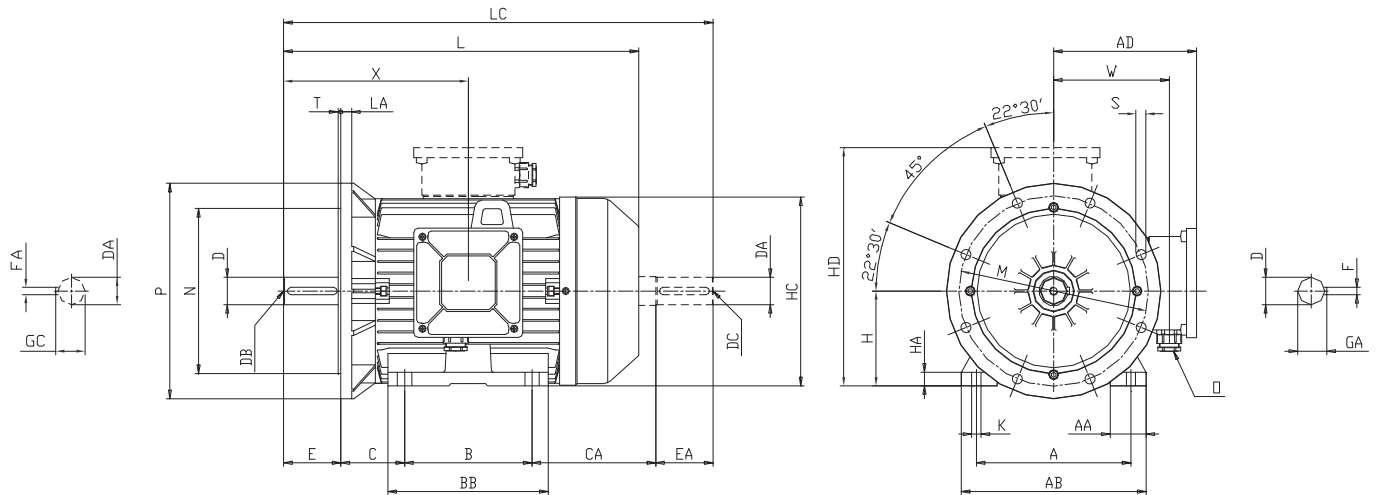

Tipo Type	Poli Poles	Dimensioni / Dimensions																	
		A	AA	AB	AD	B	BB	C	CA	H	HA	HC	HD	K	L	LC	X	W	O
225ST	4-6-8	356	80	436	315	286	370	149	270	225	30	420	515	18	830	985	445	245	M50x1.5
225MT	2	356	80	436	315	311	370	149	245	225	30	420	515	18	800	925	415	245	M50x1.5
	4-6-8	356	80	436	315	311	370	149	245	225	30	420	515	18	830	985	445	245	M50x1.5
225M	2	356	80	436	335	311	370	149	285	225	30	450	560	18	840	965	415	280	M50x1.5
	4-6-8	356	80	436	335	311	370	149	285	225	30	450	560	18	870	1025	445	280	M50x1.5
250MT	2	406	95	476	330	349	410	168	264	250	32	480	580	22	905	1061	485	270	M50x1.5
	4-6-8	406	95	476	330	349	410	168	264	250	32	480	580	22	905	1061	485	270	M50x1.5
280ST	2	457	115	534	400	368	480	190	332	280	35	535	680	22	1030	1170	540	320	M50x1.5
	4-6-8	457	115	534	400	368	480	190	332	280	35	535	680	22	1030	1170	540	320	M50x1.5
280MT	2	457	115	534	400	419	480	190	281	280	35	535	680	22	1030	1170	540	320	M50x1.5
	4-6-8	457	115	534	400	419	480	190	281	280	35	535	680	22	1030	1170	540	320	M50x1.5

Tipo Type	Poli Poles	Flangia B5 / Flange B5						Albero L.A. / DE shaft					Albero L.O.A. / NDE shaft					
		LA	M	N	P	S	T	D	E	F	GA	DB	DA	EA	FA	GC	DC	
225ST	4-6-8	16	400	350 h6	450	N.8 x 18	5	60 m6	140	18	64	M20x2.5	60 m6	140	18	64	M20x2.5	
225MT	2	16	400	350 h6	450	N.8 x 18	5	55 m6	110	16	59	M20x2.5	55 m6	110	16	59	M20x2.5	
	4-6-8	16	400	350 h6	450	N.8 x 18	5	60 m6	140	18	64	M20x2.5	60 m6	140	18	64	M20x2.5	
225M	2	16	400	350 h6	450	N.8 x 18	5	55 m6	110	16	59	M20x2.5	55 m6	110	16	59	M20x2.5	
	4-6-8	16	400	350 h6	450	N.8 x 18	5	60 m6	140	18	64	M20x2.5	60 m6	140	18	64	M20x2.5	
250MT	2	18	500	450 h6	550	N.8 x 18	5	60 m6	140	18	64	M20x2.5	60 m6	140	18	64	M20x2.5	
	4-6-8	18	500	450 h6	550	N.8 x 18	5	65 m6	140	18	69	M20x2.5	65 m6	140	18	69	M20x2.5	
280ST	2	18	500	450 h6	550	N.8 x 18	5	65 m6	140	18	69	M20x2.5	65 m6	140	18	69	M20x2.5	
	4-6-8	18	500	450 h6	550	N.8 x 18	5	75 m6	140	20	79.5	M20x2.5	75 m6	140	20	79.5	M20x2.5	
280MT	2	18	500	450 h6	550	N.8 x 18	5	65 m6	140	18	69	M20x2.5	65 m6	140	18	69	M20x2.5	
	4-6-8	18	500	450 h6	550	N.8 x 18	5	75 m6	140	20	79.5	M20x2.5	75 m6	140	20	79.5	M20x2.5	

Dimensioni d'ingombro

Forma B3/B5 - Grandezza 315T÷355T
Motori autoventilati (IC 411)

Overall dimensions

Mounting B3/B5 - Frame size 315T÷355T
Self-ventilated motors (IC 411)

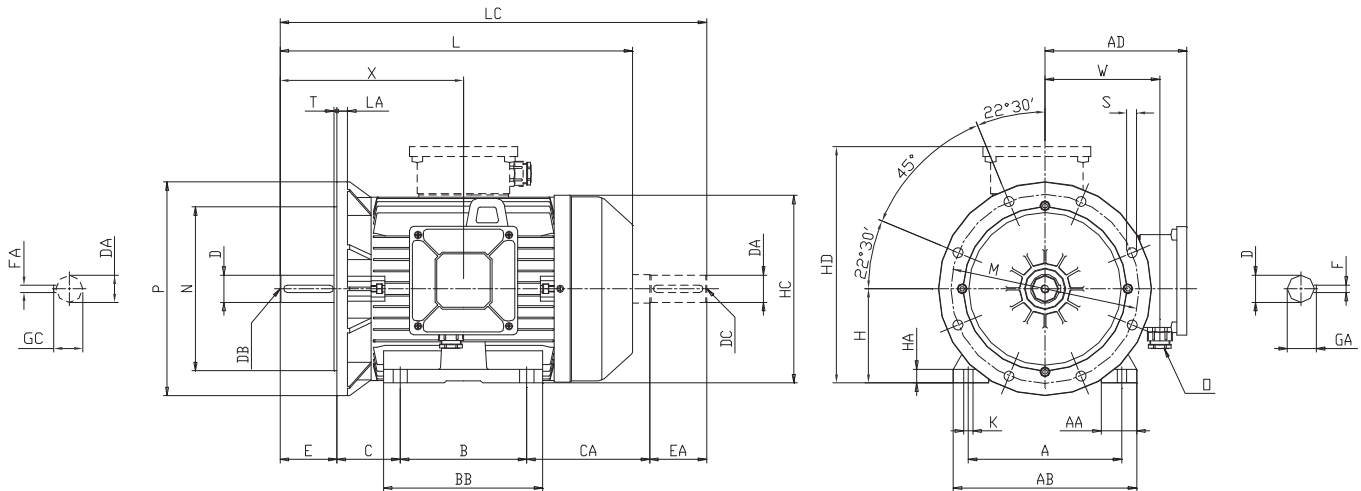

Tipo Type	Poli Poles	Dimensioni / Dimensions																	
		A	AA	AB	AD	B	BB	C	CA	H	HA	HC	HD	K	L	LC	X	W	O
315ST	2	508	130	576	400	406	480	216	293	315	38	570	715	27	1050	1195	560	320	M63x1.5
	4-6-8	508	130	576	400	406	480	216	293	315	38	570	715	27	1080	1255	590	320	M63x1.5
315M a-b-c-d	2	508	135	600	470	457	545	216	352	315	42	620	785	27	1150	1305	582	390	N.2 M63x1.5
	4-6-8								1180						1365	612			
315M e-f-g	2								1150						1305	582			
	4-6-8								1280						1470	612			
355LT	2	610	165	710	470	630	715	254	390	355	50	660	825	27	1375	1554	710	390	N.2 M63x1.5
	4-6-8	610	165	710	470	630	715	254	390	355	50	660	825	27	1445	1654	780	390	N.2 M63x1.5

Tipo Type	Poli Poles	Flangia B5 / Flange B5						Albero L.A. / DE shaft					Albero L.O.A. / NDE shaft				
		LA	M	N	P	S	T	D	E	F	GA	DB	DA	EA	FA	GC	DC
315ST	2	22	600	550 h6	660	N.8 x 22	6	65 m6	140	18	69	M20x2.5	65 m6	140	18	69	M20x2.5
	4-6-8	22	600	550 h6	660	N.8 x 22	6	80 m6	170	22	85	M20x2.5	80 m6	170	22	85	M20x2.5
315M a-b-c-d e-f-g	2	22	600	550 h6	660	N.8 x 22	6	65 m6	140	18	69	M20x2.5	65 m6	140	18	69	M20x2.5
	4-6-8							80 m6	170	22	85	M20x2.5	80 m6	170	22	85	M20x2.5
355LT	2	25	740	680 h6	800	N.8 x 22	6	75 m6	140	20	79.5	M20x2.5	75 m6	140	20	79.5	M20x2.5
	4-6-8	25	740	680 h6	800	N.8 x 22	6	100 m6	210	28	106	M24x3	90 m6	170	25	95	M24x3

Dimensioni d'ingombro

Forma B3/B5 - Grandezza 355L÷355Lx
Motori autoventilati (IC 411)

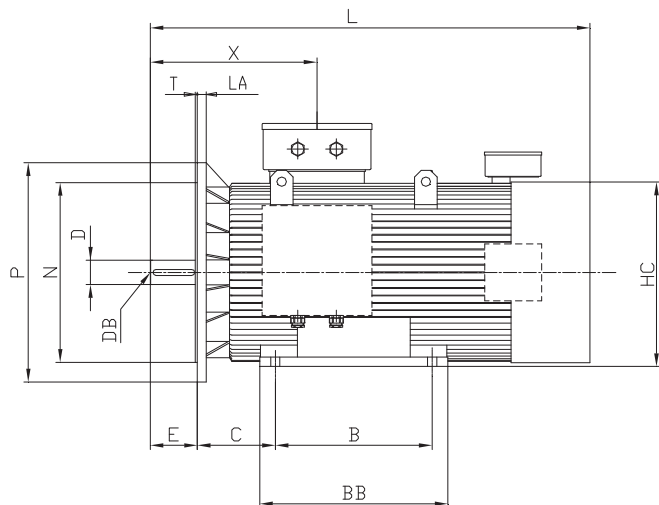

Overall dimensions

Mounting B3/B5 - Frame size 355L÷355Lx
Self-ventilated motors (IC 411)

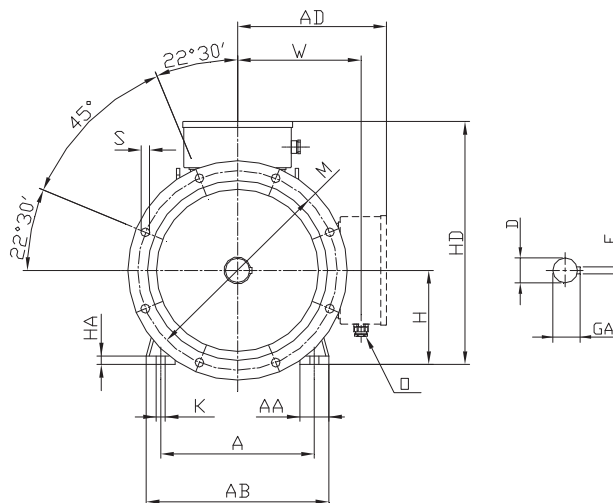

Tipo Type	Poli Poles	Dimensioni / Dimensions															
		A	AA	AB	AD	B	BB	C	H	HA	HC	HD	K	L	X	W	O
355L a-b-c	2	610	120	730	545	630	700	254	355	35	690	900	27	1470	495	450	N.2 M63x1.5
	4-6-8													1540	565		
355Lx a-b-c-d	4-6-8	610	120	730	615	630	700	254	355	35	750	970	27	1770	570	515	N.2 M63x1.5

Tipo Type	Poli Poles	Flangia B5 / Flange B5						Albero L.A. / DE shaft				
		LA	M	N	P	S	T	D	E	F	GA	DB
355L a-b-c	2	25	740	680 h6	800	N.8 x 22	6	75 m6	140	20	79.5	M20x2.5
	4-6-8							100 m6	210	28	106	M24x3
355Lx a-b-c-d	4-6-8	25	740	680 h6	800	N.8 x 22	6	100 m6	210	28	106	M24x3

Dimensioni d'ingombro

Forma B3/B5 - Grandezza 400Lx÷500Lx Motori autoventilati (IC 411)

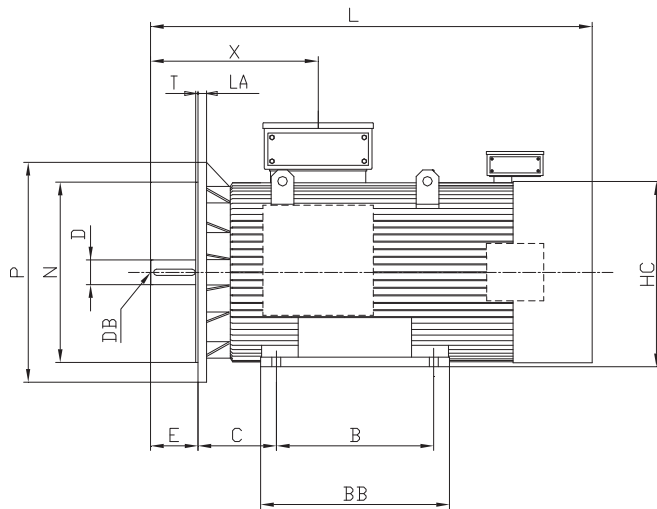

Overall dimensions

Mounting B3/B5 - Frame size 400Lx÷500Lx Self-ventilated motors (IC 411)

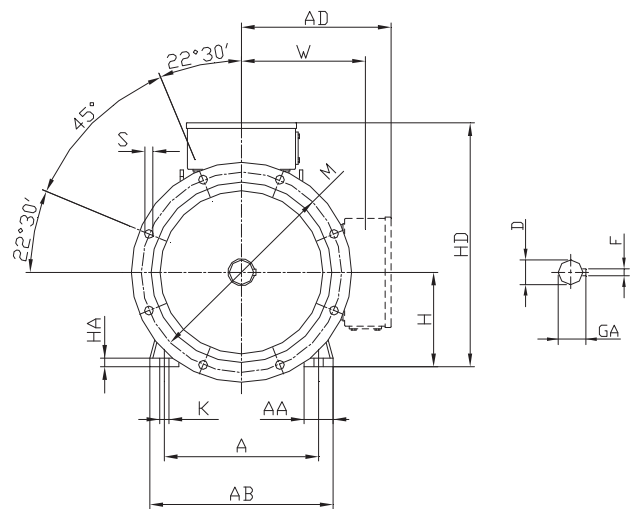

Tipo Type	Poli Poles	Dimensioni / Dimensions												
		A	AA	AB	AD	B	BB	C	H	HA	HC	HD	K	L
400Lxa	4-6-8	686	120	806	720 ⁽¹⁾	710	790	280	400	40	850	1120 ⁽¹⁾	33	1950
400Lxb					860 ⁽²⁾							1260 ⁽²⁾		
400Lxc														
450Lxa		750	120	900	770 ⁽¹⁾	800	1000	315	450	45	938	1220 ⁽¹⁾	33	2100
450Lxb					910 ⁽²⁾							1360 ⁽²⁾		
500Lxa		850	150	950	830 ⁽¹⁾	900	1000	335	500	45	1035	1330 ⁽¹⁾	35	2260
500Lxb					970 ⁽²⁾							1470 ⁽²⁾		
500Lxc														

(1) Motore fornito con N.3 morsetti

(2) Motore fornito con N.6 morsetti

(1) Motor supplied with No.3 terminals

(2) Motor supplied with No.6 terminals

Tipo Type	Poli Poles	Flangia B5 / Flange B5						Albero L.A. / DE shaft				
		LA	M	N	P	S	T	D	E	F	GA	DB
400Lxa	4-6-8	28	940	880 h6	1000	N.8 x 28	6	110 m6	210	28	116	-
400Lxb												
400Lxc												
450Lxa	4-6-8	28	940	880 h6	1000	N.8 x 28	6	110 m6	210	28	116	-
450Lxb												
500Lxa	4-6-8	28	940	880 h6	1000	N.8 x 28	6	130 m6	250	32	137	-
500Lxb												
500Lxc												

Dimensioni d'ingombro

Overall dimensions

Forma B14 - Grandezza 63÷100
Motori autoventilati (IC 411)

Mounting B14 - Frame size 63÷100
Self-ventilated motors (IC 411)

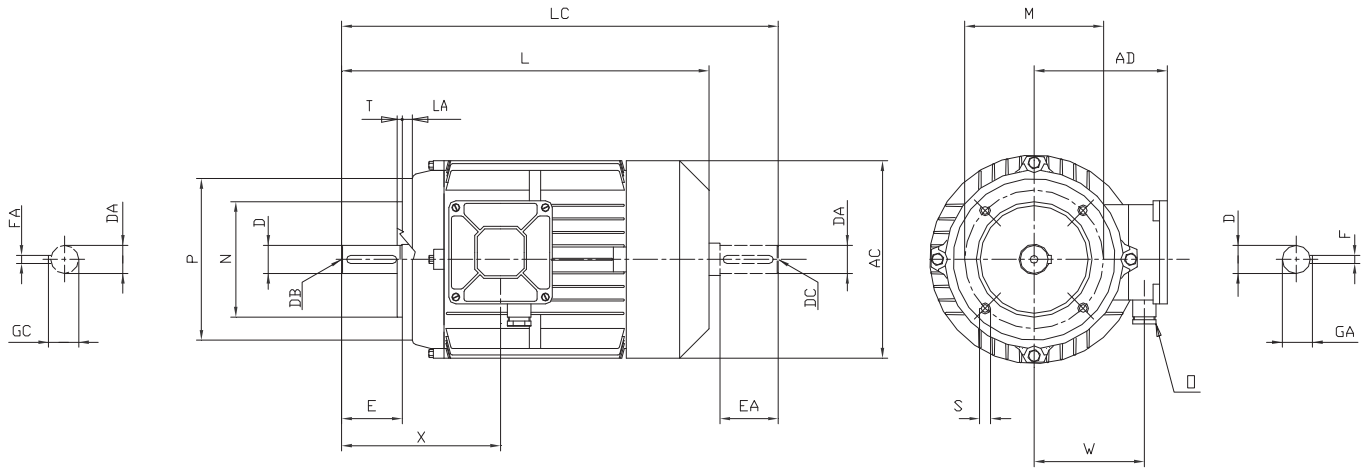

Tipo Type	Poli Poles	Dimensioni / Dimensions												
		AC	AD	L	LA	LC	M	N	P	S	T	X	W	O
63	2-4-6-8	125	95	212	8	239	75	60 j6	90	N.4xM5	2.5	86	68	M16x1.5
							85	70 j6	105	N.4xM6	2.5			
							100	80 j6	120	N.4xM6	3			
71		148	115	238	8	280	85	70 j6	105	N.4xM6	2.5	111	88	M20x1.5
					10		100	80 j6	120	N.4xM6	3			
					115		95 j6	140	N.4xM8	3				
80		170	126	274	8	325	85	70 j6	105	N.4xM6	2.5	113	96	M20x1.5
					10		100	80 j6	120	N.4xM6	3			
					115		95 j6	140	N.4xM8	3				
					130		110 j6	160	N.4xM8	3.5				
90S		185	142	297	10	374	115	95 j6	140	N.4xM8	3	134	115	M20x1.5
							130	110 j6	160	N.4xM8	3.5			
90L	185	142	322	10	399	115	95 j6	140	N.4xM8	3	134	115	M20x1.5	
						130	110 j6	160	N.4xM8	3.5				
100L	210	155	361	10	430	130	110 j6	160	N.4xM8	3.5	160	123	M25x1.5	
						165	130 j6	200	N.4xM10	3.5				

Tipo Type	Poli Poles	Flangia B5 / Flange B5					Albero L.A. / DE shaft				
		D	E	F	GA	DB	DA	EA	FA	GC	DC
63	2-4-6-8	11 j6	23	4	12.5	M4x0.7	11 j6	23	4	12.5	M4x0.7
71		14 j6	30	5	16	M5x0.8	14 j6	30	5	16	M5x0.8
80		19 j6	40	6	21.5	M6x1	19 j6	40	6	21.5	M6x1
90S		24 j6	50	8	27	M8x1.25	24 j6	50	8	27	M8x1.25
90L		24 j6	50	8	27	M8x1.25	24 j6	50	8	27	M8x1.25
100L		28 j6	60	8	31	M10x1.5	28 j6	60	8	31	M10x1.5

Dimensioni d'ingombro

Forma B14 - Grandezza 112T÷160T
Motori autoventilati (IC 411)

Overall dimensions

Mounting B14 - Frames size 112T÷160T
Self-ventilated motors (IC 411)

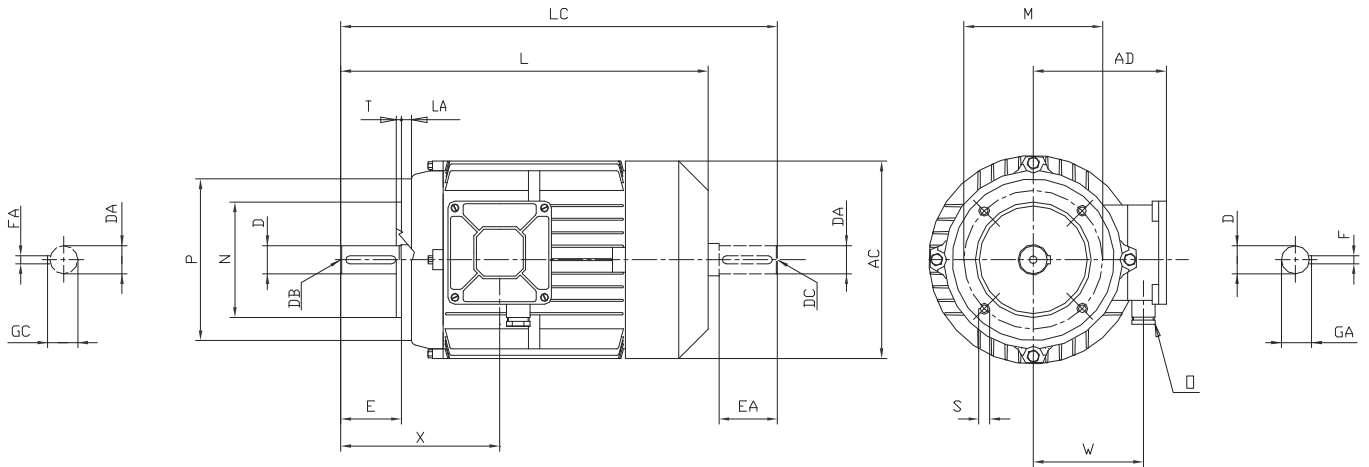

Tipo Type	Poli Poles	Dimensioni / Dimensions													
		AC	AD	L	LA	LC	M	N	P	S	T	X	W	O	
112MT	2-4-6-8	210	155	361	10	430	130	110 j6	160	N.4xM8	3.5	160	123	M25x1.5	
							165	130 j6	200	N.4xM10	3.5				
112M		225	166	380	10	444	130	110 j6	160	N.4xM8	3.5	157	140	M25x1.5	
							165	130 j6	200	N.4xM10	3.5				
132S		2-4-6-8	260	200	470	15	556	130	110 j6	160	N.4xM8	3.5	198	162	M25x1.5
								165	130 j6	200	N.4xM10	3.5			
								215	180 j6	250	N.4xM12	4			
132M			260	200	496	15	600	130	110 j6	160	N.4xM8	3.5	198	162	M25x1.5
	165							130 j6	200	N.4xM10	3.5				
	215							180 j6	250	N.4xM12	4				
160MT	260	215	570	18	673	215	180 j6	250	N.4xM12	4	275	170	M32x1.5		

Tipo Type	Poli Poles	Flangia B5 / Flange B5					Albero L.A. / DE shaft				
		D	E	F	GA	DB	DA	EA	FA	GC	DC
112MT	2-4-6-8	28 j6	60	8	31	M10x1.5	28 j6	60	8	31	M10x1.5
112M		28 j6	60	8	31	M10x1.5	28 j6	60	8	31	M10x1.5
132S		38 k6	80	10	41	M12x1.75	38 k6	80	10	41	M12x1.75
132M		38 k6	80	10	41	M12x1.75	38 k6	80	10	41	M12x1.75
160MT		42 k6	110	12	45	M16x2	38 k6	80	10	41	M12x1.75

Dimensioni d'ingombro

Forma B14 - Grandezza 160÷180T
Motori autoventilati (IC 411)

Overall dimensions

Mounting B14 - Frame size 160÷180T
Self-ventilated motors (IC 411)

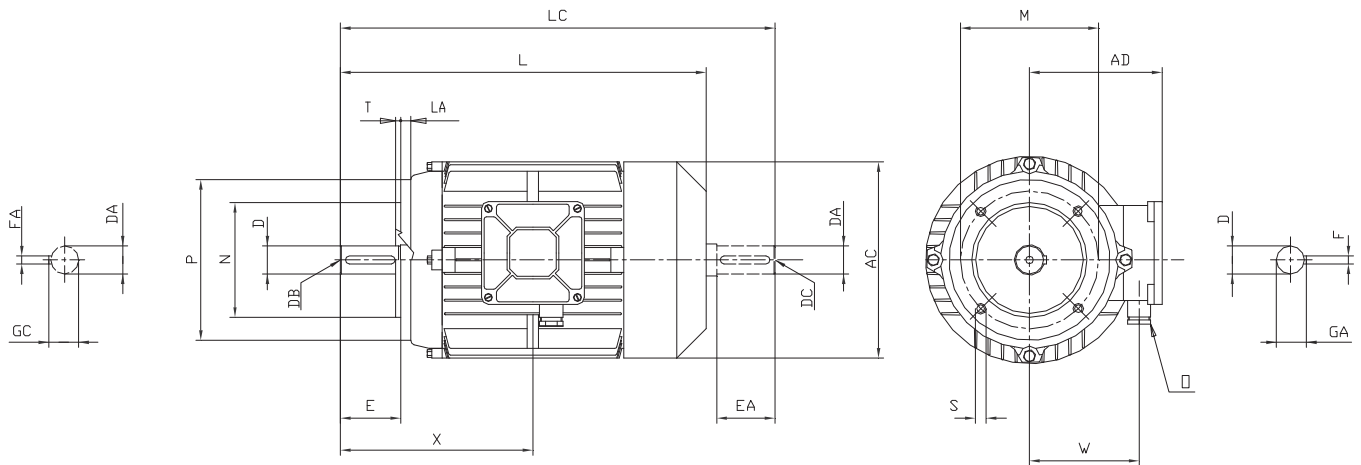

Tipo Type	Poli Poles	Dimensioni / Dimensions												
		AC	AD	L	LA	LC	M	N	P	S	T	X	W	O
160M	2-4-6-8	320	245	650	18	765	215	180 j6	250	N.4xM12	4	345	195	M40x1.5
160L		320	245	650	18	765	215	180 j6	250	N.4xM12	4	345	195	M40x1.5
180MT		320	245	690	18	824	215	180 j6	250	N.4xM12	4	370	195	M40x1.5
180LT		320	245	690	18	824	215	180 j6	250	N.4xM12	4	370	195	M40x1.5

Tipo Type	Poli Poles	Flangia B5 / Flange B5					Albero L.A. / DE shaft				
		D	E	F	GA	DB	DA	EA	FA	GC	DC
160M	2-4-6-8	42 k6	110	12	45	M16x2	42 k6	110	12	45	M16x2
160L		42 k6	110	12	45	M16x2	42 k6	110	12	45	M16x2
180MT		48 k6	110	14	51.5	M16x2	48 k6	110	14	51.5	M16x2
180LT		48 k6	110	14	51.5	M16x2	48 k6	110	14	51.5	M16x2

Motori con ventilazione assistita (IC 416)

Motors with assisted ventilation (IC 416)

Tutti i motori serie C possono essere forniti con un sistema di ventilazione IC 416.

In tal caso viene installato un opportuno ventilatore all'interno o all'esterno del copriventola.

La ventilazione risulta pertanto indipendente dalla velocità di rotazione del motore stesso.

Tale soluzione è particolarmente idonea per i motori alimentati da inverter.

All C series motors can be supplied with cooling system IC 416 on request.

In this case a proper fan is fitted inside or outside the fan cover.

Consequently the ventilation is independent of the rotation speed of the motor itself.

This solution is particularly suitable for inverter supplied motors.

Simbolo Symbol	Tensione nominale Rated voltage	Frequenza Frequency	Corrente nominale Rated current	Potenza assorbita Input Power
	V	Hz	A	W
90S-L	230/400	50	0.21 / 0.12	43
100L				
112T				
112M				
132S-M	230/400	50	0.16 / 0.22	110
160T				
160M-L	230/400	50	0.36 / 0.21	85
180 T				
180L	230/400	50	0.45 / 0.26	95
200T				
200L	230/400	50	0.70 / 0.40	155
225T				
225	230/400	50	0.70 / 0.40	145
250T				
250M	230/400	50	3.5 / 2	1000
280T				
315T				
315M	230/400	50	8.6 / 5	2000
355T				
355L				
355X	230/400	50	9.4 / 5.4	2800
400X				
450X	230/400	50	19.5 / 11.3	6400
500X				

Nelle pagine successive sono riportate le dimensioni d'ingombro dei motori servoventilati con sistema di ventilazione IC 416.

A richiesta del cliente i motori possono essere forniti con encoder; in tal caso la quota totale (L) non subirà variazioni.

In the next pages are mentioned the overall dimensions of the motors with independent ventilation with ventilation system IC 416.

On request the motors can be supplied with the encoder. in which case the total length (L) will not increase.

Dimensioni d'ingombro

Forma B3 - Grandezza 90÷160T
Motori servoventilati (IC 416)

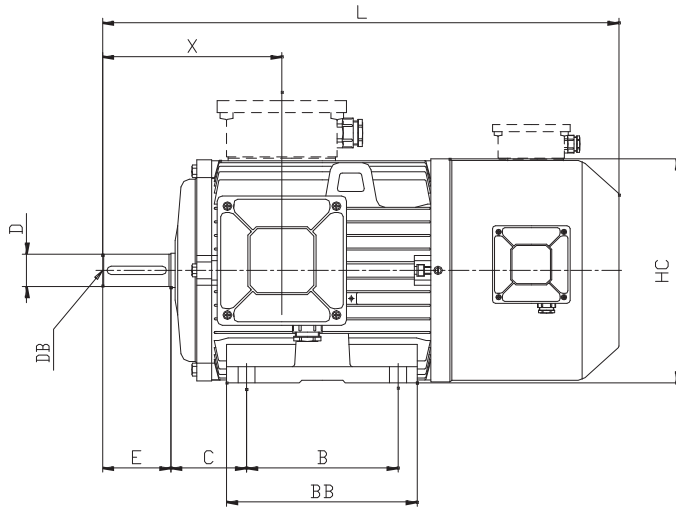

Overall dimensions

Mounting B3 - Frame size 90÷160T
Forced-ventilated motors (IC 416)

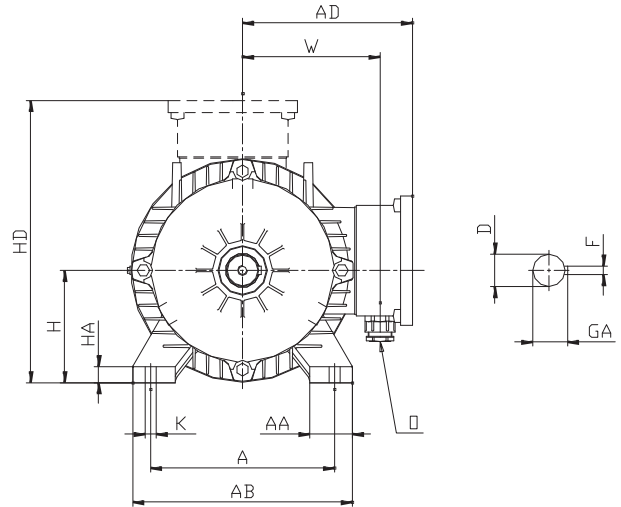

Tipo Type	Poli Poles	Dimensioni / Dimensions															
		A	AA	AB	AD	B	BB	C	H	HA	HC	HD	K	L	X	W	O
90S	2-4-6-8	140	34	175	142	100	125	56	90	12	180	232	10	470	134	115	M20x1.5
90L		140	34	175	142	125	150	56	90	12	180	232	10	495	134	115	M20x1.5
100L		160	37	198	155	140	173	63	100	14	205	255	12	530	160	123	M25x1.5
112MT		190	38	224	155	140	178	70	112	15	217	267	12	530	160	123	M25x1.5
112M		190	38	228	170	140	172	70	112	17	222	282	13	540	157	140	M25x1.5
132S		216	50	258	200	140	225	89	132	19	264	332	13	610	198	162	M25x1.5
132M		216	50	258	200	178	225	89	132	19	264	332	13	648	198	162	M25x1.5
160MT		254	60	292	215	210	250	108	160	18	290	375	14	705	275	170	M32x1.5

Tipo Type	Poli Poles	Albero L.A. / DE shaft				
		D	E	F	GA	DB
90S	2-4-6-8	24 j6	50	8	27	M8x1.25
90L		24 j6	50	8	27	M8x1.25
100L		28 j6	60	8	31	M10x1.5
112MT		28 j6	60	8	31	M10x1.5
112M		28 j6	60	8	31	M10x1.5
132S		38 k6	80	10	41	M12x1.75
132M		38 k6	80	10	41	M12x1.75
160MT		42 k6	110	12	45	M16x2

Dimensioni d'ingombro

Forma B3 - Grandezza 160÷200
Motori servoventilati (IC 416)

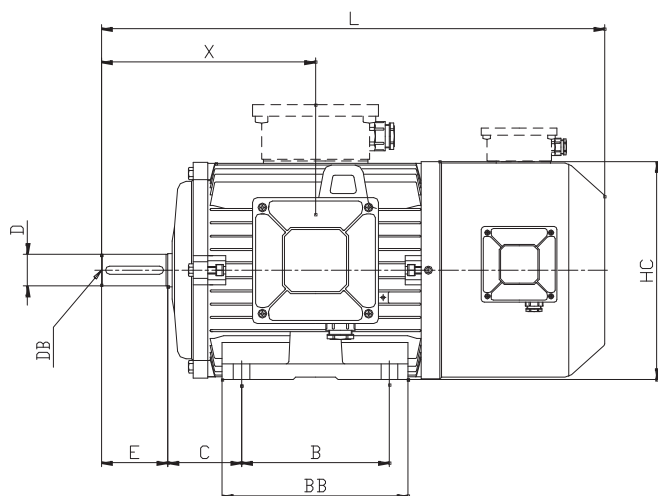

Overall dimensions

Mounting B3 - Frame size 160÷200
Forced-ventilated motors (IC 416)

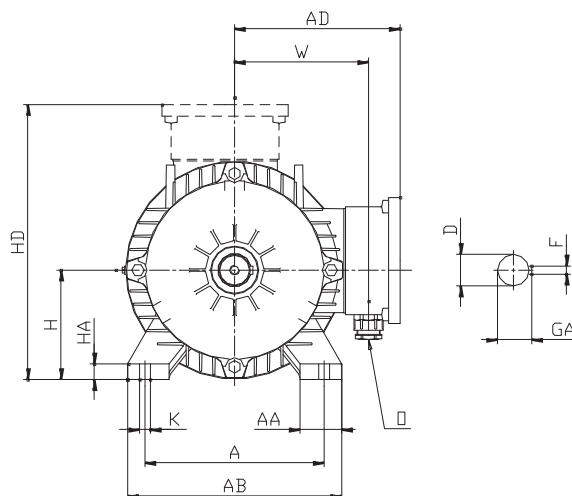

Tipo Type	Poli Poles	Dimensioni / Dimensions															
		A	AA	AB	AD	B	BB	C	H	HA	HC	HD	K	L	X	W	O
160M	2-4-6-8	254	67	315	245	210	332	108	160	20	325	405	14	765	345	195	M40x1.5
160L		254	67	315	245	254	332	108	160	20	325	405	14	765	345	195	M40x1.5
180MT		279	80	350	245	241	320	121	180	22	340	425	14	810	370	195	M40x1.5
180LT		279	80	350	245	279	320	121	180	22	340	425	14	810	370	195	M40x1.5
180L		279	80	350	275	279	320	121	180	22	360	450	14	850	370	221	M40x1.5
200LT		318	90	395	275	305	365	133	200	24	380	475	18	875	400	215	M40x1.5
200L		318	90	395	315	305	365	133	200	24	405	505	18	890	400	255	M50x1.5

Tipo Type	Poli Poles	Albero L.A. / DE shaft				
		D	E	F	GA	DB
160M	2-4-6-8	42 k6	110	12	45	M16x2
160L		42 k6	110	12	45	M16x2
180MT		48 k6	110	14	51.5	M16x2
180LT		48 k6	110	14	51.5	M16x2
180L		48 k6	110	14	51.5	M16x2
200LT		55 m6	110	16	59	M20x2.5
200L		55 m6	110	16	59	M20x2.5

Dimensioni d'ingombro

Forma B3 - Grandezza 225T÷250T
Motori servoventilati (IC 416)

Overall dimensions

Mounting B3 - Frame size 225T÷250T
Forced-ventilated motors (IC 416)

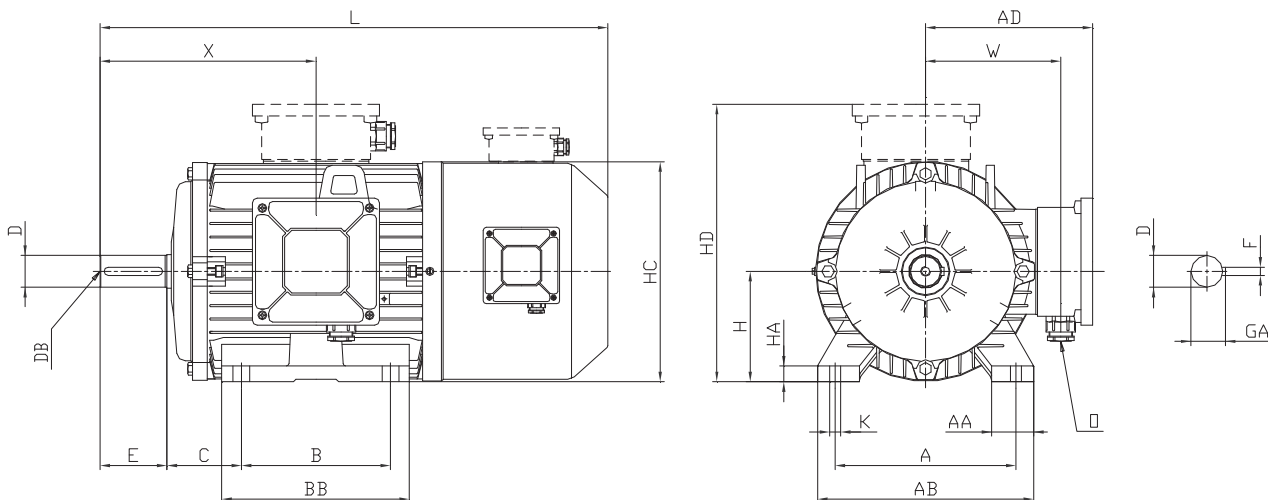

Tipo Type	Poli Poles	Dimensioni / Dimensions															
		A	AA	AB	AD	B	BB	C	H	HA	HC	HD	K	L	X	W	O
225ST	4-6-8	356	80	436	315	286	370	149	225	30	420	515	18	995	445	245	M50x1.5
225MT	2	356	80	436	315	311	370	149	225	30	420	515	18	965	415	245	M50x1.5
	4-6-8	356	80	436	315	311	370	149	225	30	420	515	18	995	445	245	M50x1.5
225M	2	356	80	436	335	311	370	149	225	30	450	560	18	1040	415	280	M50x1.5
	4-6-8	356	80	436	335	311	370	149	225	30	450	560	18	1070	445	280	M50x1.5
250MT	2	406	95	476	330	349	410	168	250	32	480	580	22	1105	485	270	M50x1.5
	4-6-8	406	95	476	330	349	410	168	250	32	480	580	22	1105	485	270	M50x1.5

Tipo Type	Poli Poles	Albero L.A. / DE shaft				
		D	E	F	GA	DB
225ST	4-6-8	60 m6	140	18	64	M20x2.5
225MT	2	55 m6	110	16	59	M20x2.5
	4-6-8	60 m6	140	18	64	M20x2.5
225M	2	55 m6	110	16	59	M20x2.5
	4-6-8	60 m6	140	18	64	M20x2.5
250MT	2	60 m6	140	18	64	M20x2.5
	4-6-8	65 m6	140	18	69	M20x2.5

Dimensioni d'ingombro

Forma B3 - Grandezza 250÷355T
Motori servoventilati (IC 416)

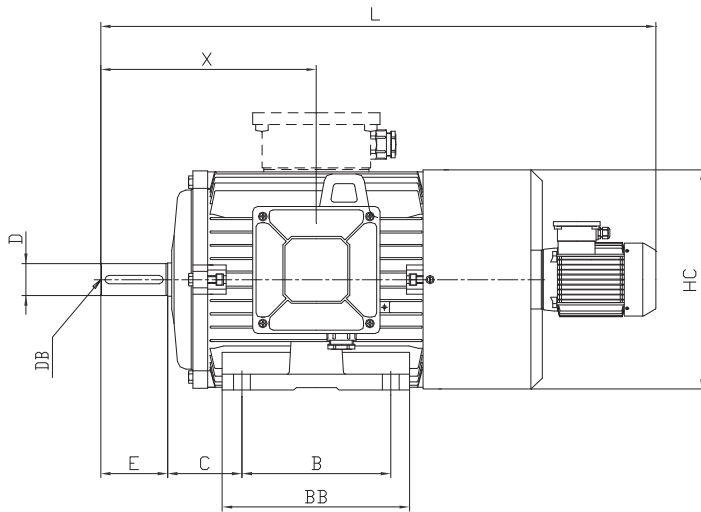

Overall dimensions

Mounting B3 - Frame size 250÷355T
Forced-ventilated motors (IC 416)

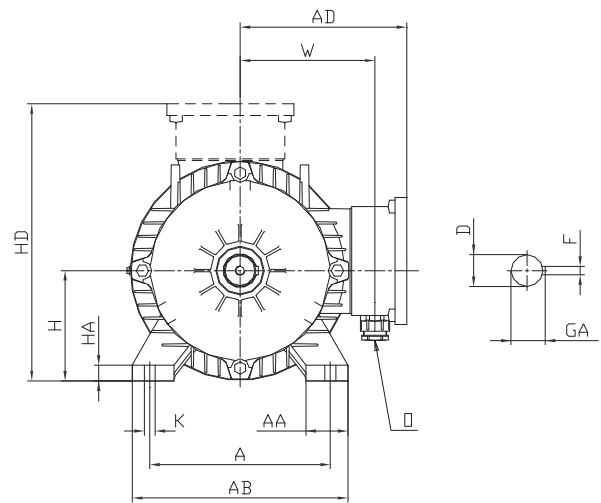

Tipo Type	Poli Poles	Dimensioni / Dimensions																
		A	AA	AB	AD	B	BB	C	H	HA	HC	HD	K	L	X	W	O	
280ST	2	457	115	534	400	368	480	190	280	35	535	680	22	1355	540	320	M50x1.5	
	4-6-8	457	115	534	400	368	480	190	280	35	535	680	22	1355	540	320	M50x1.5	
280MT	2	457	115	534	400	419	480	190	280	35	535	680	22	1355	540	320	M50x1.5	
	4-6-8	457	115	534	400	419	480	190	280	35	535	680	22	1355	540	320	M50x1.5	
315ST	2	508	130	576	400	406	480	216	315	38	575	715	27	1370	560	320	M63x1.5	
	4-6-8	508	130	576	400	406	480	216	315	38	575	715	27	1400	590	320	M63x1.5	
315M a-b-c-d	2	508	135	600	470	457	545	216	315	42	620	785	27	1495	582	390	N.2 M63x1.5	
	4-6-8													1525	612			
315M e-f-g	2	508	135	600	470	457	545	216	315	42	620	785	27	1495	582	390		N.2 M63x1.5
	4-6-8													1740	612			
355LT	2	610	165	710	470	630	715	254	355	50	660	825	27	1825	710	390	N.2 M63x1.5	
	4-6-8	610	165	710	470	630	715	254	355	50	660	825	27	1895	780	390	N.2 M63x1.5	

Tipo Type	Poli Poles	Albero L.A. / DE shaft				
		D	E	F	GA	DB
280ST	2	65 m6	140	18	69	M20x2.5
	4-6-8	75 m6	140	20	79.5	M20x2.5
280MT	2	65 m6	140	18	69	M20x2.5
	4-6-8	75 m6	140	20	79.5	M20x2.5
315ST	2	65 m6	140	18	69	M20x2.5
	4-6-8	80 m6	170	22	85	M20x2.5
315M a-b-c-d-e-f-g	2	65 m6	140	18	69	M20x2.5
	4-6-8	80 m6	170	22	85	M20x2.5
355LT	2	75 m6	140	20	79.5	M20x2.5
	4-6-8	100 m6	210	28	106	M24x3

Dimensioni d'ingombro

Overall dimensions

Forma B3 - Grandezza 355L÷355Lx
Motori servoventilati (IC 416)

Mounting B3 - Frame size 355L÷355Lx
Forced-ventilated motors (IC 416)

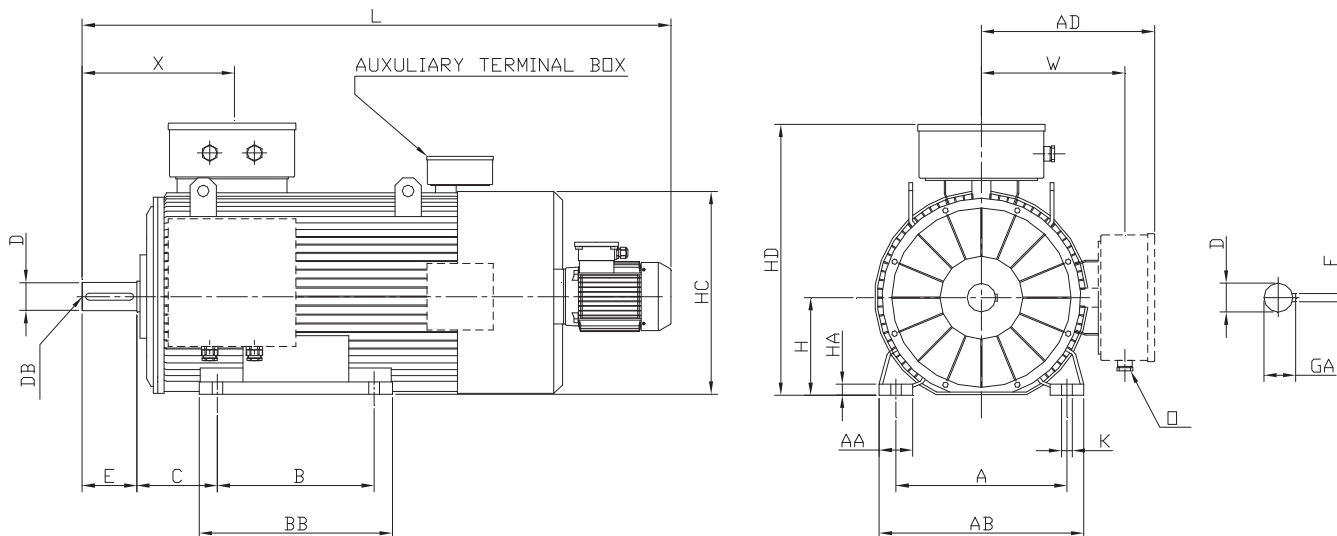

Tipo Type	Poli Poles	Dimensioni / Dimensions															
		A	AA	AB	AD	B	BB	C	H	HA	HC	HD	K	L	X	W	O
355L a-b-c	2	610	120	730	545	630	700	254	355	35	690	900	27	1840	495	450	N.2 M63x1.5
	4-6-8													1910	565		
355Lx a-b-c-d	4-6-8	610	120	730	615	630	700	254	355	35	750	970	27	2150	570	515	N.2 M63x1.5

Tipo Type	Poli Poles	Albero L.A. / DE shaft				
		D	E	F	GA	DB
355L a-b-c	2	75 m6	140	20	79.5	M20x2.5
	4-6-8	100 m6	210	28	106	M24x3
355Lx a-b-c-d	4-6-8	100 m6	210	28	106	M24x3

Dimensioni d'ingombro

Forma B3 - Grandezza 400Lx÷500Lx
Motori servoventilati (IC 416)

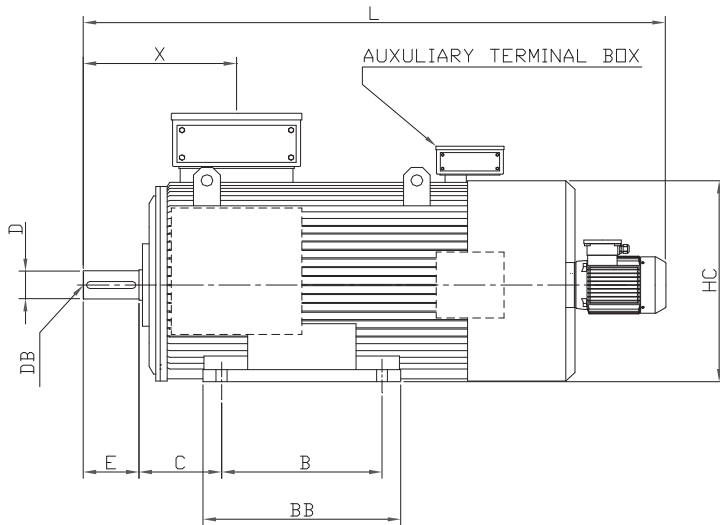

Overall dimensions

Mounting B3 - Frame size 400Lx÷500Lx
Forced-ventilated motors (IC 416)

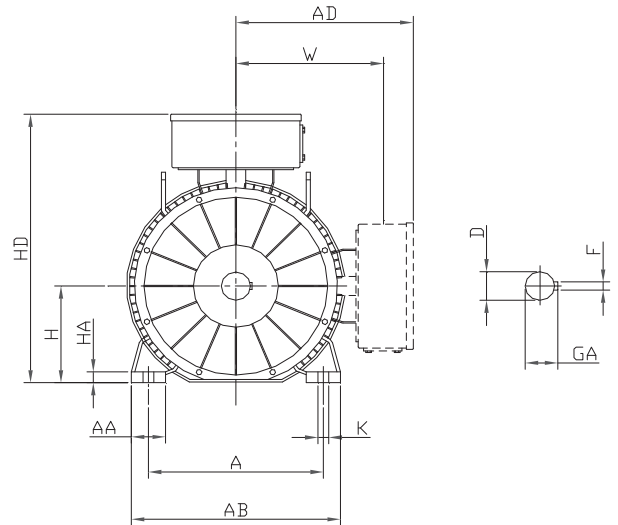

Tipo Type	Poli Poles	Dimensioni / Dimensions												
		A	AA	AB	AD	B	BB	C	H	HA	HC	HD	K	L
400Lxa	4-6-8	686	120	806		710	790	280	400	40	850		33	2500
400Lxb					720 ⁽¹⁾							1120 ⁽¹⁾		2600
400Lxc					860 ⁽²⁾							1260 ⁽²⁾		2600
450Lxa		750	120	900	770 ⁽¹⁾	800	1000	315	450	45	938	1220 ⁽¹⁾	33	2700
450Lxb					910 ⁽²⁾							1360 ⁽²⁾		2700
500Lxa		850	150	950		900	1000	335	500	45	1035		35	3260
500Lxb					830 ⁽¹⁾							1330 ⁽¹⁾		3360
500Lxc					970 ⁽²⁾							1470 ⁽²⁾		3360

(1) Motore fornito con N.3 morsetti
(2) Motore fornito con N.6 morsetti

(1) Motor supplied with No.3 terminals
(2) Motor supplied with No.6 terminals

Tipo Type	Poli Poles	Albero L.A. / DE shaft				
		D	E	F	GA	DB
400Lxa	4-6-8	110 m6	210	28	116	-
450Lxa	4-6-8	110 m6	210	28	116	-
500Lxa	4-6-8	130 m6	250	32	137	-

Dimensioni d'ingombro

Forma B5 - Grandezza 90÷160T
 Forma V1 - Grandezza 90÷160T
 Motori servoventilati (IC 416)

Overall dimensions

Mounting B5 - Frame size 90÷160T
 Mounting V1 - Frame size 90÷160T
 Forced-ventilated motors (IC 416)

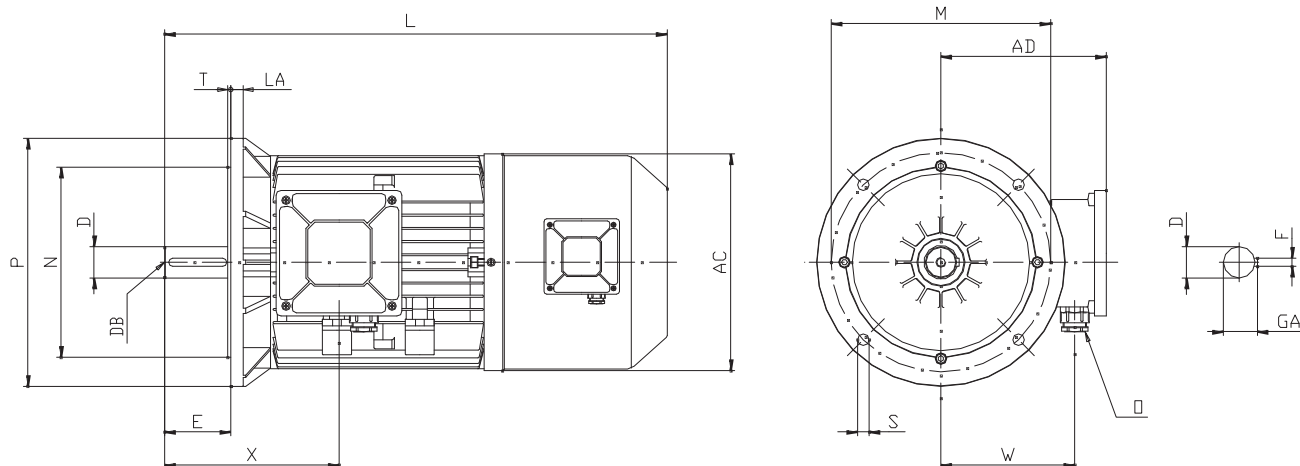

Tipo Type	Poli Poles	Dimensioni / Dimensions											
		AC	AD	L	LA	M	N	P	S	T	X	W	O
90S	2-4-6-8	185	142	470	12	165	130 j6	200	N.4 x 11.5	3.5	134	115	M20x1.5
90L		185	142	495	12	165	130 j6	200	N.4 x 11.5	3.5	134	115	M20x1.5
100L		210	155	530	14	215	180 j6	250	N.4 x 14	4	160	123	M25x1.5
112MT		210	155	530	14	215	180 j6	250	N.4 x 14	4	160	123	M25x1.5
112M		225	166	540	14	215	180 j6	250	N.4 x 14	4	157	140	M25x1.5
132S		260	200	610	14	265	230 j6	300	N.4 x 14	4	198	162	M25x1.5
132M		260	200	648	14	265	230 j6	300	N.4 x 14	4	198	162	M25x1.5
160MT		260	215	705	15	300	250 h6	350	N.4 x 18	5	275	170	M32x1.5

Tipo Type	Poli Poles	Albero L.A. / DE shaft				
		D	E	F	GA	DB
90S	2-4-6-8	24 j6	50	8	27	M8x1.25
90L		24 j6	50	8	27	M8x1.25
100L		28 j6	60	8	31	M10x1.5
112MT		28 j6	60	8	31	M10x1.5
112M		28 j6	60	8	31	M10x1.5
132S		38 k6	80	10	41	M12x1.75
132M		38 k6	80	10	41	M12x1.75
160MT		42 k6	110	12	45	M16x2

Dimensioni d'ingombro

Forma B5 - Grandezza 160÷200
 Forma V1 - Grandezza 160÷200
 Motori servoventilati (IC 416)

Overall dimensions

Mounting B5 - Frame size 160÷200
 Mounting V1 - Frame size 160÷200
 Forced-ventilated motors (IC 416)

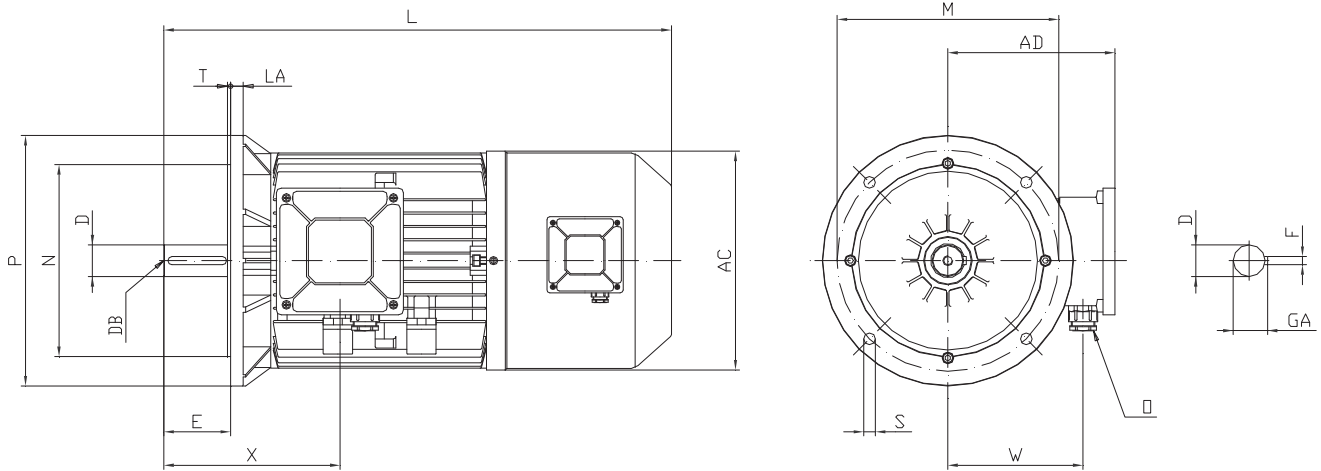

Tipo Type	Poli Poles	Dimensioni / Dimensions											
		AC	AD	L	LA	M	N	P	S	T	X	W	O
160M	2-4-6-8	320	245	765	15	300	250 h6	350	N.4 x 18	5	345	195	M40x1.5
160L		320	245	765	15	300	250 h6	350	N.4 x 18	5	345	195	M40x1.5
180MT		320	245	810	15	300	250 h6	350	N.4 x 18	5	370	195	M40x1.5
180LT		320	245	810	15	300	250 h6	350	N.4 x 18	5	370	195	M40x1.5
180L		360	270	850	15	300	250 h6	350	N.4 x 18	5	370	221	M40x1.5
200LT		360	275	875	15	350	300 h6	400	N.4 x 18	5	400	215	M40x1.5
200L		395	315	890	15	350	300 h6	400	N.4 x 18	5	400	255	M40x1.5

Tipo Type	Poli Poles	Albero L.A. / DE shaft				
		D	E	F	GA	DB
160M	2-4-6-8	42 k6	110	12	45	M16x2
160L		42 k6	110	12	45	M16x2
180MT		48 k6	110	14	51.5	M16x2
180LT		48 k6	110	14	51.5	M16x2
180L		48 k6	110	14	51.5	M16x2
200LT		55 m6	110	16	59	M20x2.5
200L		55 m6	110	16	59	M20x2.5

Dimensioni d'ingombro

Forma B5 - Grandezza 225T÷250T
 Forma V1 - Grandezza 225T÷250T
 Motori servoventilati (IC 416)

Overall dimensions

Mounting B5 - Frame size 225T÷250T
 Mounting V1 - Frame size 225T÷250T
 Forced-ventilated motors (IC 416)

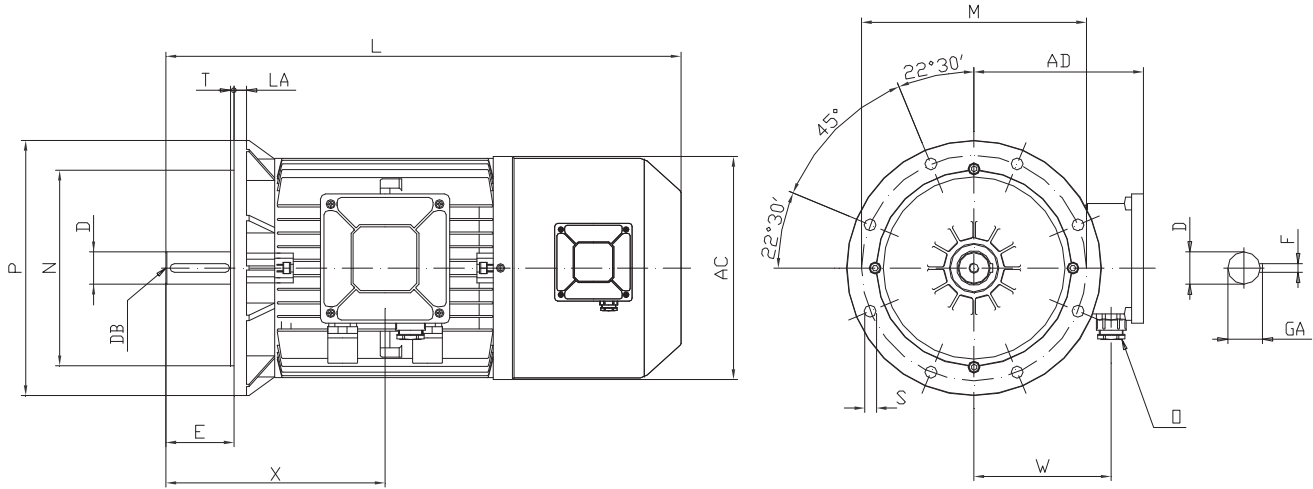

Tipo Type	Poli Poles	Dimensioni / Dimensions											
		AC	AD	L	LA	M	N	P	S	T	X	W	O
225ST	4-6-8	400	315	995	16	400	350 h6	450	N.8 x 18	5	445	245	M50x1.5
225MT	2	400	315	965	16	400	350 h6	450	N.8 x 18	5	415	245	M50x1.5
	4-6-8	400	315	995	16	400	350 h6	450	N.8 x 18	5	445	245	M50x1.5
225M	2	450	335	1040	16	400	350 h6	450	N.8 x 18	5	415	280	M50x1.5
	4-6-8	450	335	1070	16	400	350 h6	450	N.8 x 18	5	445	280	M50x1.5
250MT	2	450	330	1105	18	500	450 h6	550	N.8 x 18	5	485	270	M50x1.5
	4-6-8	450	330	1105	18	500	450 h6	550	N.8 x 18	5	485	270	M50x1.5

Tipo Type	Poli Poles	Albero L.A. / DE shaft				
		D	E	F	GA	DB
225ST	4-6-8	60 m6	140	18	64	M20x2.5
225MT	2	55 m6	110	16	59	M20x2.5
	4-6-8	60 m6	140	18	64	M20x2.5
225M	2	55 m6	110	16	59	M20x2.5
	4-6-8	60 m6	140	18	64	M20x2.5
250MT	2	60 m6	140	18	64	M20x2.5
	4-6-8	65 m6	140	18	69	M20x2.5

Dimensioni d'ingombro

Forma B5 - Grandezza 250÷355T
 Forma V1 - Grandezza 250÷355T
 Motori servoventilati (IC 416)

Overall dimensions

Mounting B5 - Frame size 250÷355T
 Mounting V1 - Frame size 250÷355T
 Forced-ventilated motors (IC 416)

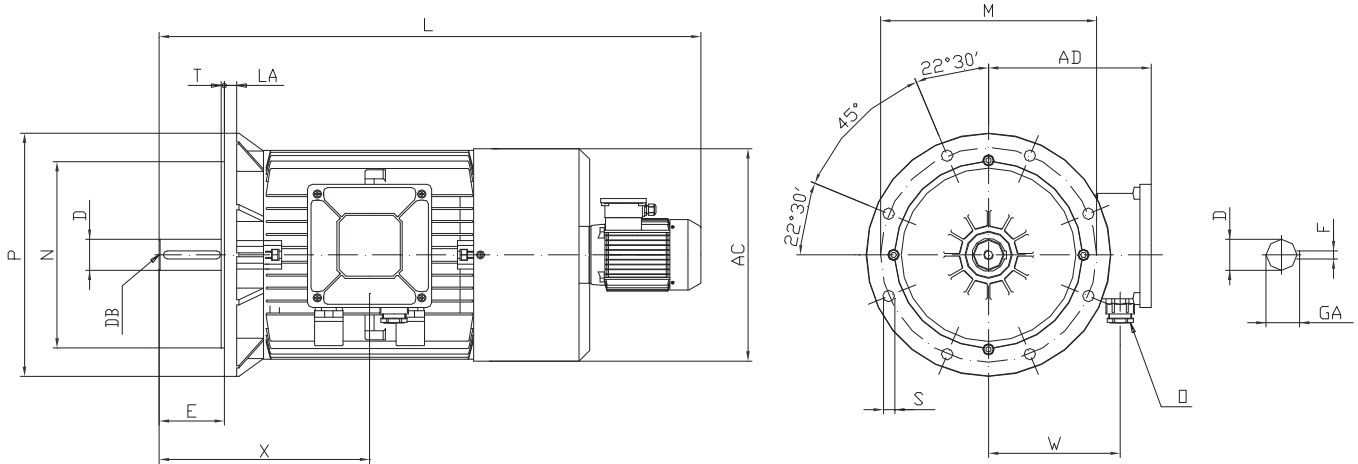

Tipo Type	Poli Poles	Dimensioni / Dimensions											
		AC	AD	L	LA	M	N	P	S	T	X	W	O
280ST	2	510	400	1355	18	500	450 h6	550	N.8 x 18	5	540	320	M50x1.5
	4-6-8	510	400	1355	18	500	450 h6	550	N.8 x 18	5	540	320	M50x1.5
280MT	2	510	400	1355	18	500	450 h6	550	N.8 x 18	5	540	320	M50x1.5
	4-6-8	510	400	1355	18	500	450 h6	550	N.8 x 18	5	540	320	M50x1.5
315ST	2	520	400	1370	22	600	550 h6	660	N.8 x 22	6	560	320	M63x1.5
	4-6-8	520	400	1400	22	600	550 h6	660	N.8 x 22	6	590	320	M63x1.5
315M a-b-c-d	2	610	470	1495	22	600	550 h6	660	N.8 x 22	6	582	390	N.2 M63x1.5
	4-6-8			1525							612		
315M e-f-g	2			1495							582		
	4-6-8			1740							612		
355LT	2	610	470	1825	25	740	680 h6	800	N.8 x 22	6	710	390	N.2 M63x1.5
	4-6-8	610	470	1895	25	740	680 h6	800	N.8 x 22	6	780	390	N.2 M63x1.5

Tipo Type	Poli Poles	Albero L.A. / DE shaft				
		D	E	F	GA	DB
280ST	2	65 m6	140	18	69	M20x2.5
	4-6-8	75 m6	140	20	79.5	M20x2.5
280MT	2	65 m6	140	18	69	M20x2.5
	4-6-8	75 m6	140	20	79.5	M20x2.5
315ST	2	65 m6	140	18	69	M20x2.5
	4-6-8	80 m6	170	22	85	M20x2.5
315M a-b-c-d-e-f-g	2	65 m6	140	18	69	M20x2.5
	4-6-8	80 m6	170	22	85	M20x2.5
355LT	2	75 m6	140	20	79.5	M20x2.5
	4-6-8	100 m6	210	28	106	M24x3

Dimensioni d'ingombro

Forma B3/B5 - Grandezza 90÷160T
Motori servoventilati (IC 416)

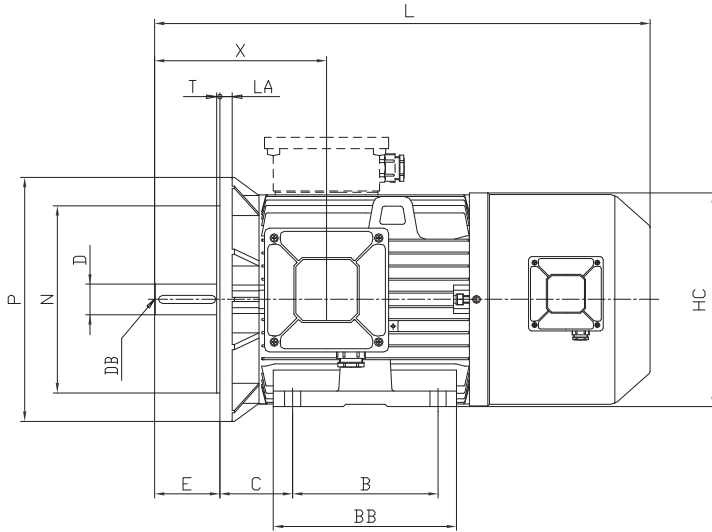

Overall dimensions

Mounting B3/B5 - Frame size 90÷160T
Forced-ventilated motors (IC 416)

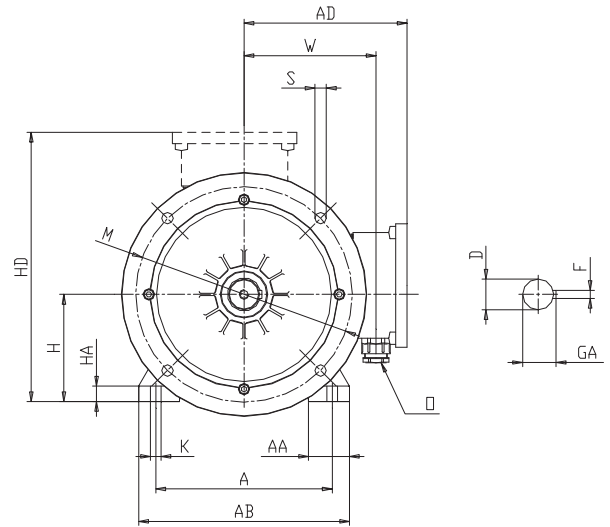

Tipo Type	Poli Poles	Dimensioni / Dimensions															
		A	AA	AB	AD	B	BB	C	H	HA	HC	HD	K	L	X	W	O
90S	2-4-6-8	140	34	175	142	100	125	56	90	12	180	232	10	470	134	115	M20x1.5
90L		140	34	175	142	125	150	56	90	12	180	232	10	495	134	115	M20x1.5
100L		160	37	198	155	140	173	63	100	14	205	255	12	530	160	123	M25x1.5
112MT		190	38	224	155	140	178	70	112	15	217	267	12	530	160	123	M25x1.5
112M		190	38	228	170	140	172	70	112	17	222	282	13	540	157	140	M25x1.5
132S		216	50	258	200	140	225	89	132	19	264	332	13	610	198	162	M25x1.5
132M		216	50	258	200	178	225	89	132	19	264	332	13	648	198	162	M25x1.5
160MT		254	60	292	215	210	250	108	160	18	290	375	14	705	275	170	M32x1.5

Tipo Type	Poli Poles	Flangia B5 / Flange B5						Albero L.A. / DE shaft				
		LA	M	N	P	S	T	D	E	F	GA	DB
90S	2-4-6-8	12	165	130 j6	200	N.4 x 11.5	3.5	24 j6	50	8	27	M8x1.25
90L		12	165	130 j6	200	N.4 x 11.5	3.5	24 j6	50	8	27	M8x1.25
100L		14	215	180 j6	250	N.4 x 14	4	28 j6	60	8	31	M10x1.5
112MT		14	215	180 j6	250	N.4 x 14	4	28 j6	60	8	31	M10x1.5
112M		14	215	180 j6	250	N.4 x 14	4	28 j6	60	8	31	M10x1.5
132S		14	265	230 j6	300	N.4 x 14	4	38 k6	80	10	41	M12x1.75
132M		14	265	230 j6	300	N.4 x 14	4	38 k6	80	10	41	M12x1.75
160MT		15	300	250 h6	350	N.4 x 18	5	42 k6	110	12	45	M16x2

Dimensioni d'ingombro

Forma B3/B5 - Grandezza 160÷200
Motori servoventilati (IC 416)

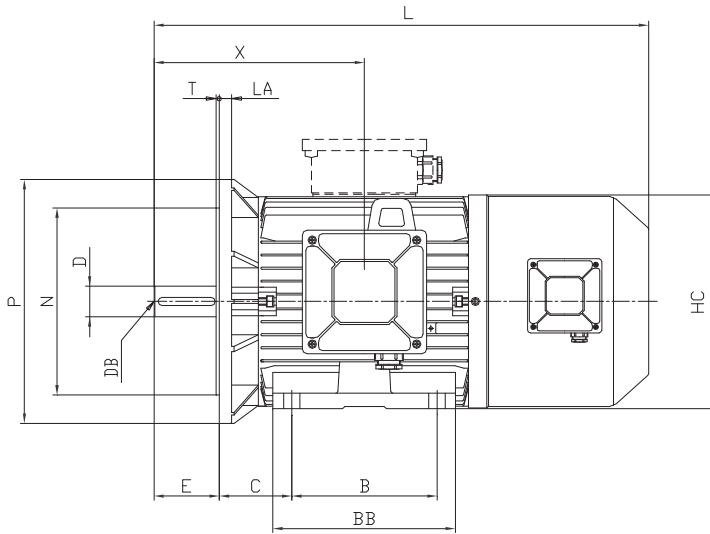

Overall dimensions

Mounting B3/B5 - Frame size 160÷200
Forced-ventilated motors (IC 416)

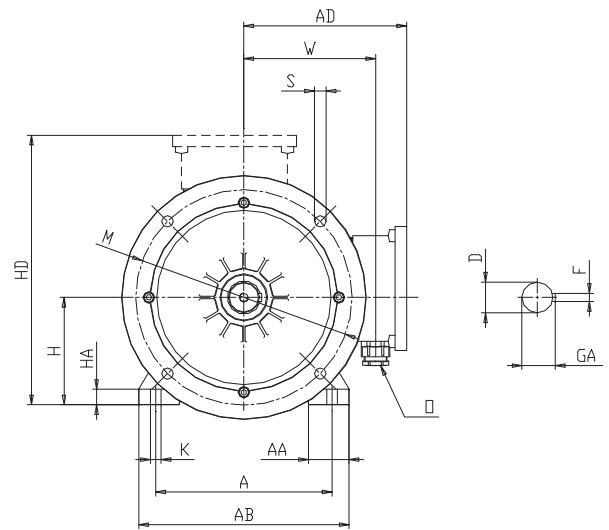

Tipo Type	Poli Poles	Dimensioni / Dimensions															
		A	AA	AB	AD	B	BB	C	H	HA	HC	HD	K	L	X	W	O
160M	2-4-6-8	254	67	315	245	210	332	108	160	20	325	405	14	765	345	195	M40x1.5
160L		254	67	315	245	254	332	108	160	20	325	405	14	765	345	195	M40x1.5
180MT		279	80	350	245	241	320	121	180	22	340	425	14	810	370	195	M40x1.5
180LT		279	80	350	245	279	320	121	180	22	340	425	14	810	370	195	M40x1.5
180L		279	80	350	275	279	320	121	180	22	360	450	14	850	370	221	M40x1.5
200LT		318	90	395	275	305	365	133	200	24	380	475	18	875	400	215	M40x1.5
200L		318	90	395	315	305	365	133	200	24	405	505	18	890	400	255	M50x1.5

Tipo Type	Poli Poles	Flangia B5 / Flange B5						Albero L.A. / DE shaft					
		LA	M	N	P	S	T	D	E	F	GA	DB	
160M	2-4-6-8	15	300	250 h6	350	N.4 x 18	5	42 k6	110	12	45	M16x2	
160L		15	300	250 h6	350	N.4 x 18	5	42 k6	110	12	45	M16x2	
180MT		15	300	250 h6	350	N.4 x 18	5	48 k6	110	14	51.5	M16x2	
180LT		15	300	250 h6	350	N.4 x 18	5	48 k6	110	14	51.5	M16x2	
180L		15	300	250 h6	350	N.4 x 18	5	48 k6	110	14	51.5	M16x2	
200LT		15	350	300 h6	400	N.4 x 18	5	55 m6	110	16	59	M20x2.5	
200L		15	350	300 h6	400	N.4 x 18	5	55 m6	110	16	59	M20x2.5	

Dimensioni d'ingombro

Forma B3/B5 - Grandezza 225T÷250T
Motori servoventilati (IC 416)

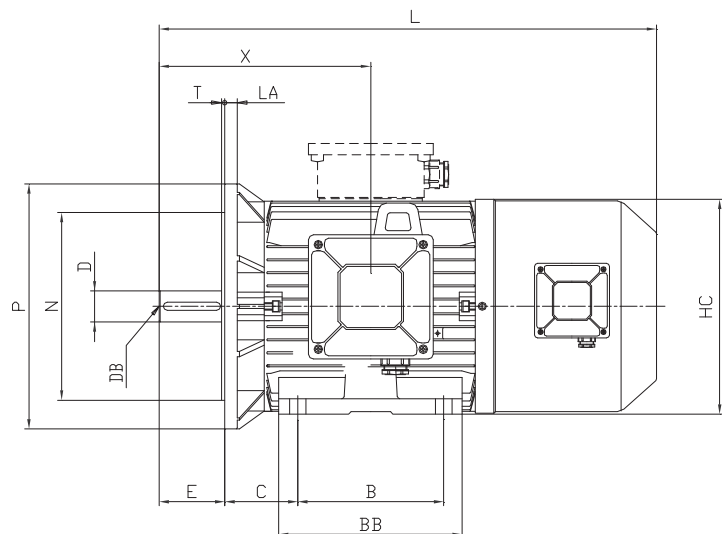

Overall dimensions

Mounting B3/B5 - Frame size 225T÷250T
Forced-ventilated motors (IC 416)

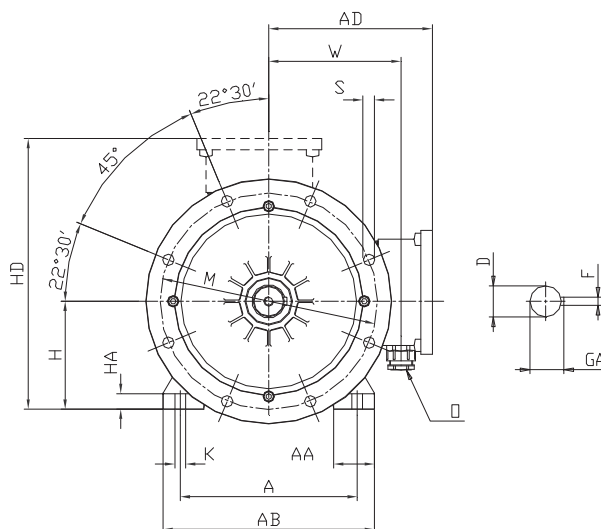

Tipo Type	Poli Poles	Dimensioni / Dimensions															
		A	AA	AB	AD	B	BB	C	H	HA	HC	HD	K	L	X	W	O
225ST	4-6-8	356	80	436	315	286	370	149	225	30	420	515	18	995	445	245	M50x1.5
225MT	2	356	80	436	315	311	370	149	225	30	420	515	18	965	415	245	M50x1.5
	4-6-8	356	80	436	315	311	370	149	225	30	420	515	18	995	445	245	M50x1.5
225M	2	356	80	436	335	311	370	149	225	30	450	560	18	1040	415	280	M50x1.5
	4-6-8	356	80	436	335	311	370	149	225	30	450	560	18	1070	445	280	M50x1.5
250MT	2	406	95	476	330	349	410	168	250	32	480	580	22	1105	485	270	M50x1.5
	4-6-8	406	95	476	330	349	410	168	250	32	480	580	22	1105	485	270	M50x1.5

Tipo Type	Poli Poles	Flangia B5 / Flange B5						Albero L.A. / DE shaft					
		LA	M	N	P	S	T	D	E	F	GA	DB	
225ST	4-6-8	16	400	350 h6	450	N.8 x 18	5	60 m6	140	18	64	M20x2.5	
225MT	2	16	400	350 h6	450	N.8 x 18	5	55 m6	110	16	59	M20x2.5	
	4-6-8	16	400	350 h6	450	N.8 x 18	5	60 m6	140	18	64	M20x2.5	
225M	2	16	400	350 h6	450	N.8 x 18	5	55 m6	110	16	59	M20x2.5	
	4-6-8	16	400	350 h6	450	N.8 x 18	5	60 m6	140	18	64	M20x2.5	
250MT	2	18	500	450 h6	550	N.8 x 18	5	60 m6	140	18	64	M20x2.5	
	4-6-8	18	500	450 h6	550	N.8 x 18	5	65 m6	140	18	69	M20x2.5	

Dimensioni d'ingombro

Forma B3/B5 - Grandezza 280T÷355T
Motori servoventilati (IC 416)

Overall dimensions

Mounting B3/B5 - Frame size 280T÷355T
Forced-ventilated motors (IC 416)

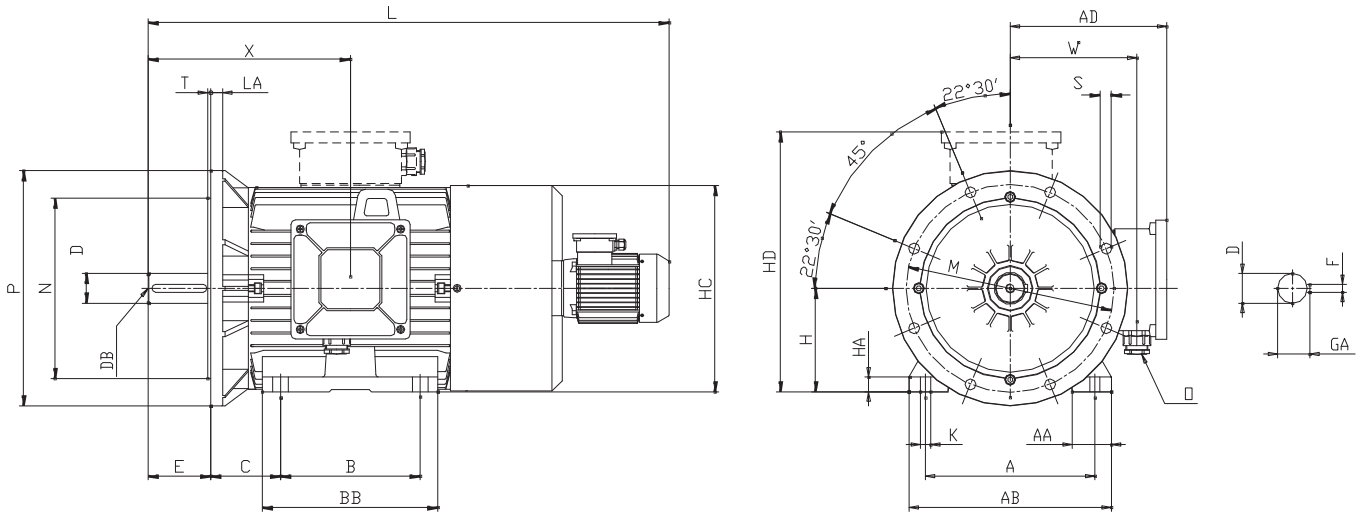

Tipo Type	Poli Poles	Dimensioni / Dimensions																
		A	AA	AB	AD	B	BB	C	H	HA	HC	HD	K	L	X	W	O	
280ST	2	457	115	534	400	368	480	190	280	35	535	680	22	1355	540	320	M50x1.5	
	4-6-8	457	115	534	400	368	480	190	280	35	535	680	22	1355	540	320	M50x1.5	
280MT	2	457	115	534	400	419	480	190	280	35	535	680	22	1355	540	320	M50x1.5	
	4-6-8	457	115	534	400	419	480	190	280	35	535	680	22	1355	540	320	M50x1.5	
315ST	2	508	130	576	400	406	480	216	315	38	570	715	27	1370	560	320	M63x1.5	
	4-6-8	508	130	576	400	406	480	216	315	38	570	715	27	1400	590	320	M63x1.5	
315M a-b-c-d	2	508	135	600	470	457	545	216	315	42	620	785	27	1495	582	390	N.2 M63x1.5	
	4-6-8													1525	612			
315M e-f-g	2	508	135	600	470	457	545	216	315	42	620	785	27	1495	582	390		N.2 M63x1.5
	4-6-8													1740	612			
355LT	2	610	165	710	470	630	715	254	355	50	660	825	27	1825	710	390	N.2 M63x1.5	
	4-6-8	610	165	710	470	630	715	254	355	50	660	825	27	1895	780	390	N.2 M63x1.5	

Tipo Type	Poli Poles	Flangia B5 / Flange B5						Albero L.A. / DE shaft				
		LA	M	N	P	S	T	D	E	F	GA	DB
280ST	2	18	500	450 h6	550	N.8 x 18	5	65 m6	140	18	69	M20x2.5
	4-6-8	18	500	450 h6	550	N.8 x 18	5	75 m6	140	20	79.5	M20x2.5
280MT	2	18	500	450 h6	550	N.8 x 18	5	65 m6	140	18	69	M20x2.5
	4-6-8	18	500	450 h6	550	N.8 x 18	5	75 m6	140	20	79.5	M20x2.5
315ST	2	22	600	550 h6	660	N.8 x 22	6	65 m6	140	18	69	M20x2.5
	4-6-8	22	600	550 h6	660	N.8 x 22	6	80 m6	170	22	85	M20x2.5
315M a-b-c-d-e-f-g	2	22	600	550 h6	660	N.8 x 22	6	65 m6	140	18	69	M20x2.5
	80 m6							170	22	85	M20x2.5	
355LT	2	25	740	680 h6	800	N.8 x 22	6	75 m6	140	20	79.5	M20x2.5
	4-6-8	25	740	680 h6	800	N.8 x 22	6	100 m6	210	28	106	M24x3

Dimensioni d'ingombro

Forma B3/B5 - Grandezza 355L÷355Lx
Motori servoventilati (IC 416)

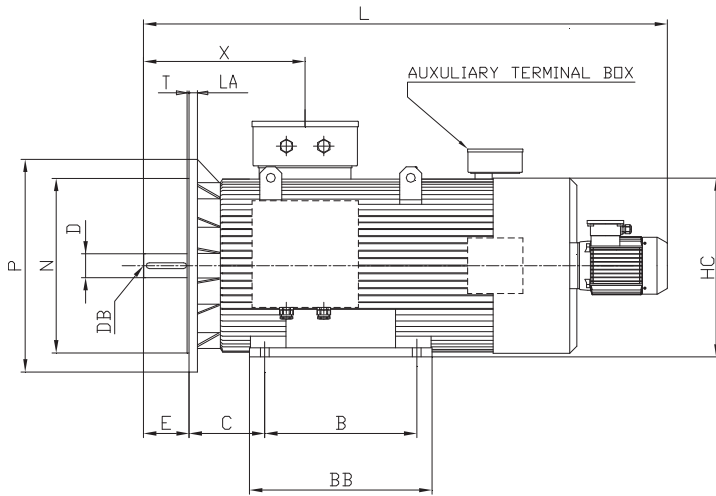

Overall dimensions

Mounting B3/B5 - Frame size 355L÷355Lx
Forced-ventilated motors (IC 416)

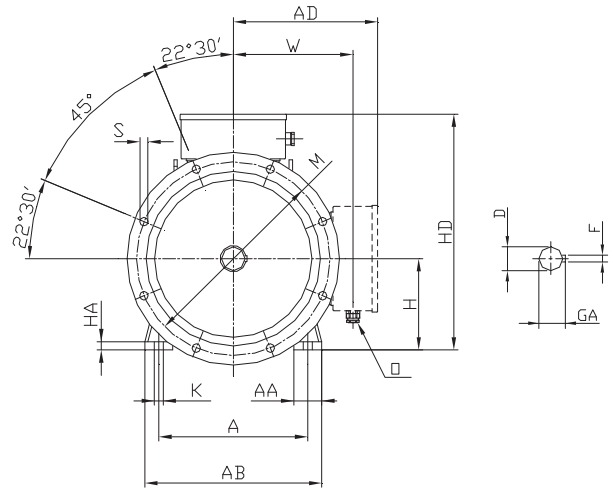

Tipo Type	Poli Poles	Dimensioni / Dimensions															
		A	AA	AB	AD	B	BB	C	H	HA	HC	HD	K	L	X	W	O
355L a-b-c	2	610	120	730	545	630	700	254	355	35	690	900	27	1840	495	450	N.2 M63x1.5
	4-6-8													1910	565		
355Lx a-b-c-d	4-6-8	610	120	730	615	630	700	254	355	35	750	970	27	2150	570	515	N.2 M63x1.5

Tipo Type	Poli Poles	Flangia B5 / Flange B5						Albero L.A. / DE shaft				
		LA	M	N	P	S	T	D	E	F	GA	DB
355L a-b-c	2	25	740	680 h6	800	N.8 x 22	6	75 m6	140	20	79.5	M20x2.5
	4-6-8							100 m6	210	28	106	M24x3
355Lx a-b-c-d	4-6-8	28	740	680 h6	800	N.8 x 22	6	100 m6	210	28	106	M24x3

Dimensioni d'ingombro

Forma B3/B5 - Grandezza 400Lx÷500Lx Motori servoventilati (IC 416)

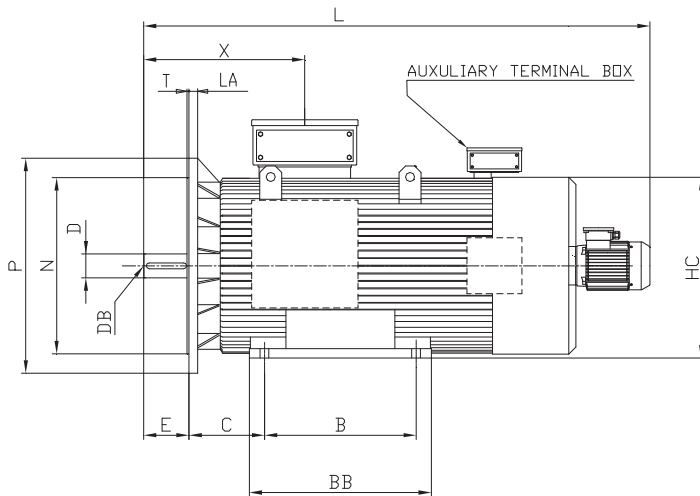

Overall dimensions

Mounting B3/B5 - Frame size 400Lx÷500Lx Forced-ventilated motors (IC 416)

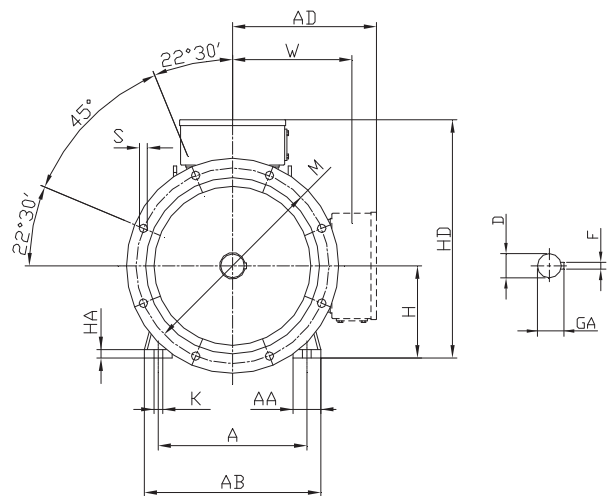

Tipo Type	Poli Poles	Dimensioni / Dimensions													
		A	AA	AB	AD	B	BB	C	H	HA	HC	HD	K	L	
400Lxa	4-6-8	686	120	806		710	790	280	400	40	850		33	2500	
400Lxb					720 ⁽¹⁾							1120 ⁽¹⁾		2600	
400Lxc					860 ⁽²⁾							1260 ⁽²⁾		2600	
450Lxa		750	120	900		800	1000	315	450	45	938		33	2700	
450Lxb					770 ⁽¹⁾							1220 ⁽¹⁾		2700	
500Lxa		850	150	950		900	1000	335	500	45	1035		35	3260	
500Lxb					830 ⁽¹⁾							1330 ⁽¹⁾		3360	
500Lxc					970 ⁽²⁾							1470 ⁽²⁾		3360	

(1) Motore fornito con N.3 morsetti

(2) Motore fornito con N.6 morsetti

(1) Motor supplied with No.3 terminals

(2) Motor supplied with No.6 terminals

Tipo Type	Poli Poles	Flangia B5 / Flange B5						Albero L.A. / DE shaft				
		LA	M	N	P	S	T	D	E	F	GA	DB
400Lxa	4-6-8	28	940	880 h6	1000	N.8 x 28	6	110 m6	210	28	116	-
400Lxb												
400Lxc												
450Lxa	4-6-8	28	940	880 h6	1000	N.8 x 28	6	110 m6	210	28	116	-
450Lxb												
500Lxa	4-6-8	28	940	880 h6	1000	N.8 x 28	6	130 m6	250	32	137	-
500Lxb												
500Lxc												

Denominazione Componenti

Name of Components

Serie CA
Grandezza 63÷112

CA Series
Frame 63÷112

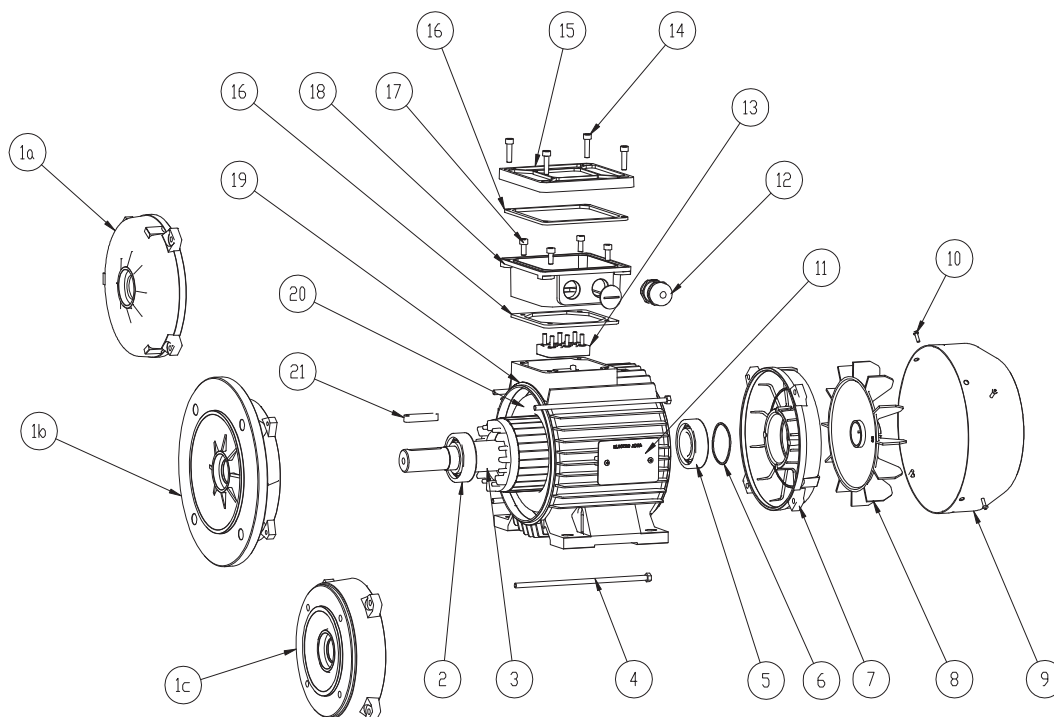

1a	Scudo anteriore	1a	Front shield
1b	Flangia B5	1b	Front shield with flange B5
1c	Flangia B14	1c	Front shield with flange B14
2	Cuscinetto anteriore	2	Front bearing
3	Albero con rotore	3	Shaft with rotor
4	Tirante	4	Tie-bolt
5	Cuscinetto posteriore	5	Rear bearing
6	Molla di compensazione	6	Compensating spring
7	Scudo posteriore	7	Rear shield
8	Ventola di raffreddamento	8	Cooling fan
9	Copriventola	9	Fan cover
10	Vite fissaggio copriventola	10	Fixing screw for fan cover
11	Targa dati motore	11	Rating plate
12	Pressacavo	12	Cable gland
13	Morsettiera	13	Terminal board
14	Vite fissaggio coperchio coprimorsettiera	14	Fixing screw for terminal box cover
15	Coperchio coprimorsettiera	15	Terminal box cover
16	Guarnizione coprimorsettiera	16	Gasket
17	Vite fissaggio coprimorsettiera	17	Fixing screw for terminal box
18	Coprimorsettiera	18	Terminal-box
19	Carcassa con statore	19	Frame with stator package
20	Avvolgimento	20	Winding
21	Chiavetta lato accoppiamento	21	Coupling side key

Denominazione Componenti

Name of Components

Serie CA Grandezza 132÷200

CA Series Frame 132÷200

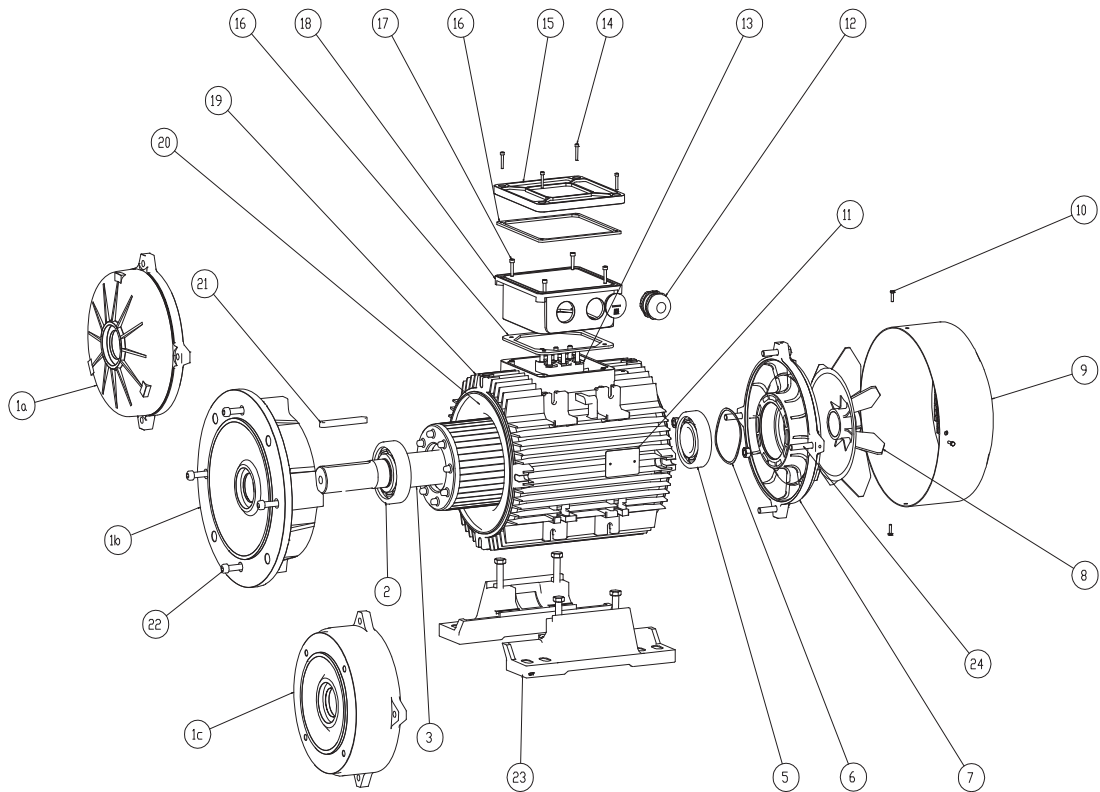

1a	Scudo anteriore	1a	Front shield
1b	Flangia B5	1b	Front shield with flange B5
1c	Flangia B14	1c	Front shield with flange B14
2	Cuscinetto anteriore	2	Front bearing
3	Albero con rotore	3	Shaft with rotor
5	Cuscinetto posteriore	5	Rear bearing
6	Molla di compensazione	6	Compensating spring
7	Scudo posteriore	7	Rear shield
8	Ventola di raffreddamento	8	Cooling fan
9	Copriventola	9	Fan cover
10	Vite fissaggio copriventola	10	Fixing screw for fan cover
11	Targa dati motore	11	Rating plate
12	Pressacavo	12	Cable gland
13	Morsettiera	13	Terminal board
14	Vite fissaggio coperchio coprimorsettiera	14	Fixing screw for terminal box cover
15	Coperchio coprimorsettiera	15	Terminal box cover
16	Guarnizione coprimorsettiera	16	Gasket
17	Vite fissaggio coprimorsettiera	17	Fixing screw for terminal box
18	Coprimorsettiera	18	Terminal-box
19	Carcassa con statore	19	Frame with stator package
20	Avvolgimento	20	Winding
21	Chiavetta lato accoppiamento	21	Coupling side key
22	Vite fissaggio flangia/scudo - carcassa	22	Fixing screw for shield/flange
23	Piedi	23	Removable foot
24	Vite fissaggio scudo - carcassa	24	Fixing screw for shield

Per altezza d'asse 132 i piedi sono di fusione con la carcassa.
Versione B14 solo fino all'altezza d'asse 180T.

For 132 frame size, feet are casted with frame.
Monting B14 till 180T frame only.

Denominazione Componenti

Name of Components

Serie CA Grandezza 225÷250

CA Series Frame 225÷250

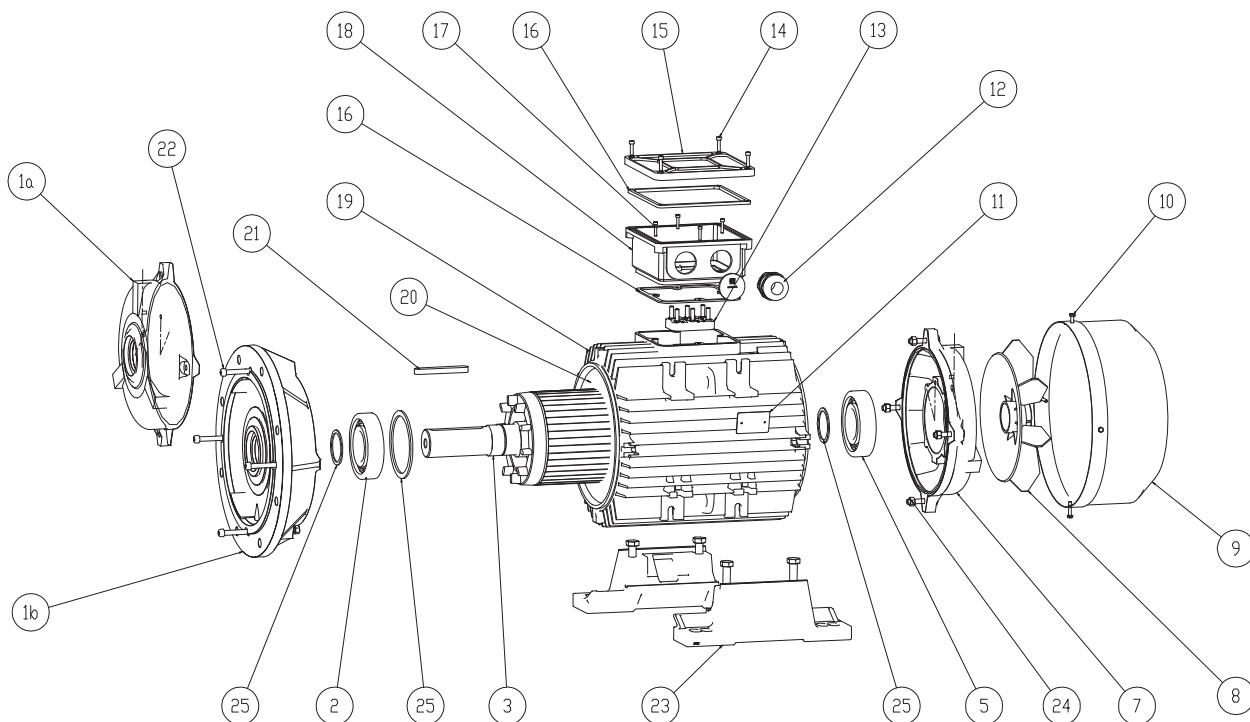

1a	Scudo anteriore	1a	Front shield
1b	Flangia B5	1b	Front shield with flange B5
2	Cuscinetto anteriore	2	Front bearing
3	Albero con rotore	3	Shaft with rotor
5	Cuscinetto posteriore	5	Rear bearing
7	Scudo posteriore	7	Rear shield
8	Ventola di raffreddamento	8	Cooling fan
9	Copriventola	9	Fan cover
10	Vite fissaggio copriventola	10	Fixing screw for fan cover
11	Targa dati motore	11	Rating plate
12	Pressacavo	12	Cable gland
13	Morsettiera	13	Terminal board
14	Vite fissaggio coperchio coprimorsettiera	14	Fixing screw for terminal box cover
15	Coperchio coprimorsettiera	15	Terminal box cover
16	Guarnizione coprimorsettiera	16	Gasket
17	Vite fissaggio coprimorsettiera	17	Fixing screw for terminal box
18	Coprimorsettiera	18	Terminal-box
19	Carcassa con statore	19	Frame with stator package
20	Avvolgimento	20	Winding
21	Chiavetta lato accoppiamento	21	Coupling side key
22	Vite fissaggio flangia/scudo - carcassa	22	Fixing screw for shield/flange
23	Piedi	23	Removable foot
24	Vite fissaggio scudo - carcassa	24	Fixing screw for shield
25	Anello elastico seeger	25	Seeger elastic ring
24	Vite fissaggio scudo - carcassa	24	Fixing screw for shield

Denominazione Componenti

Name of Components

Serie CA Grandezza 280÷315

CA Series Frame 280÷315

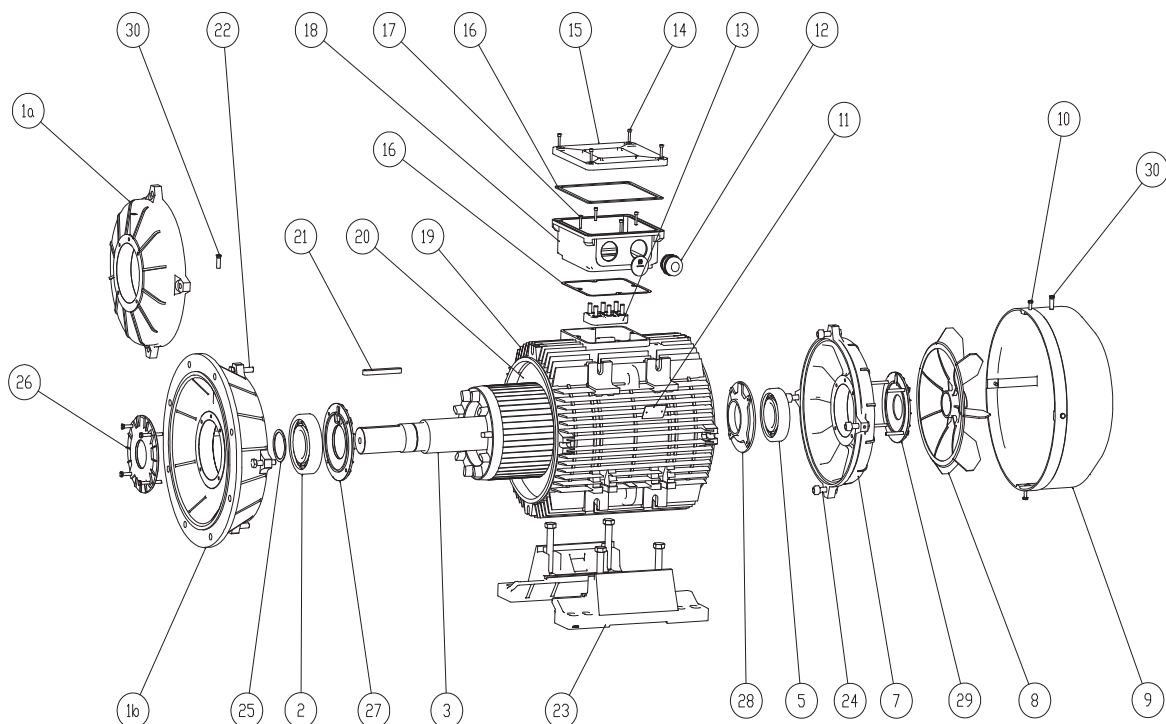

1a	Scudo anteriore	1a	Front shield
1b	Flangia B5	1b	Front shield with flange B5
2	Cuscinetto anteriore	2	Front bearing
3	Albero con rotore	3	Shaft with rotor
5	Cuscinetto posteriore	5	Rear bearing
7	Scudo posteriore	7	Rear shield
8	Ventola di raffreddamento	8	Cooling fan
9	Copriventola	9	Fan cover
10	Vite fissaggio copriventola	10	Fixing screw for fan cover
11	Targa dati motore	11	Rating plate
12	Pressacavo	12	Cable gland
13	Morsettiera	13	Terminal board
14	Vite fissaggio coperchio coprimorsettiera	14	Fixing screw for terminal box cover
15	Coperchio coprimorsettiera	15	Terminal box cover
16	Guarnizione coprimorsettiera	16	Gasket
17	Vite fissaggio coprimorsettiera	17	Fixing screw for terminal box
18	Coprimorsettiera	18	Terminal-box
19	Carcassa con statore	19	Frame with stator package
20	Avvolgimento	20	Winding
21	Chiavetta lato accoppiamento	21	Coupling side key
22	Vite fissaggio flangia/scudo - carcassa	22	Fixing screw for shield/flange
23	Piedi	23	Removable foot
24	Vite fissaggio scudo - carcassa	24	Fixing screw for shield
25	Anello elastico seeger	25	Seeger elastic ring
26	Coperchietto paragrasso anteriore esterno	26	Inner front side grease-guard cover
27	Coperchietto paragrasso anteriore interno	27	Outer front side grease-guard cover
28	Coperchietto paragrasso posteriore interno	28	Inner rear side grease-guard cover
29	Coperchietto paragrasso posteriore esterno	29	Outer rear side grease-guard cover
30	Ingrassatore "Tecalamit"	30	"Tecalamit" lubricator

Denominazione Componenti

Name of Components

Serie CS - Forma B3 - B3/B5
Grandezza 355÷500

CS Series - Mounting B3 - B3/B5
Frame 355÷500

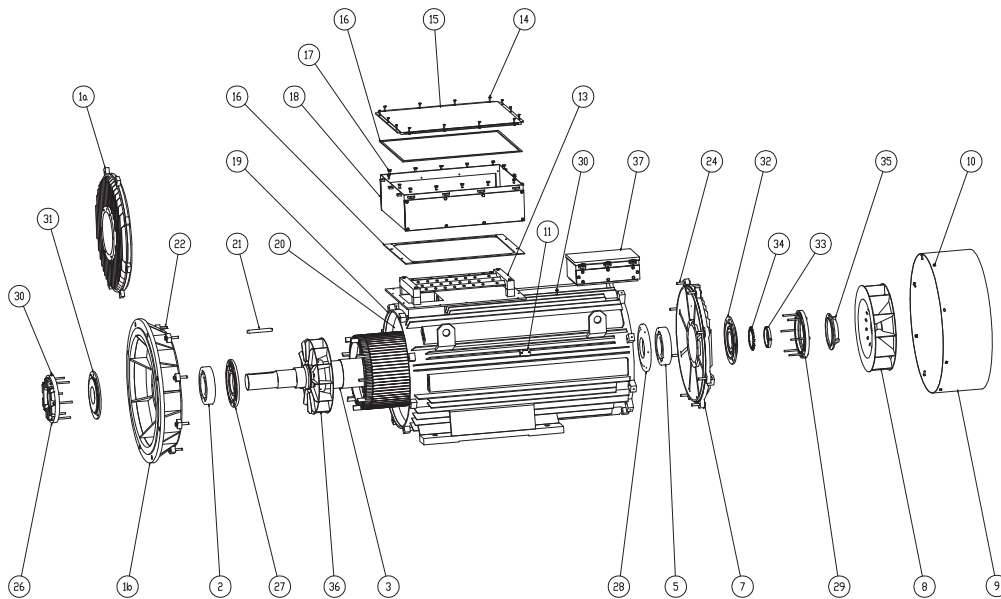

1a	Scudo anteriore	1a	Front shield
1b	Flangia B5	1b	Front shield with flange B5
2	Cuscinetto anteriore	2	Front bearing
3	Albero con rotore	3	Shaft with rotor
5	Cuscinetto posteriore	5	Rear bearing
7	Scudo posteriore	7	Rear shield
8	Ventola di raffreddamento	8	Cooling fan
9	Copriventola	9	Fan cover
10	Vite fissaggio copriventola	10	Fixing screw for fan cover
11	Targa dati motore	11	Rating plate
13	Morsettiera	13	Terminal board
14	Vite fissaggio coperchio coprimorsettiera	14	Fixing screw for terminal box cover
15	Coperchio coprimorsettiera	15	Terminal box cover
16	Guarnizione coprimorsettiera	16	Gasket
17	Vite fissaggio coprimorsettiera	17	Fixing screw for terminal box
18	Coprimorsettiera	18	Terminal-box
19	Carcassa con statore	19	Frame with stator package
20	Avvolgimento	20	Winding
21	Chiavetta lato accoppiamento	21	Coupling side key
22	Vite fissaggio flangia/scudo - carcassa	22	Fixing screw for shield/flange
24	Vite fissaggio scudo - carcassa	24	Fixing screw for shield
26	Coperchietto paragrasso anteriore esterno	26	Inner front side grease-guard cover
27	Coperchietto paragrasso anteriore interno	27	Outer front side grease-guard cover
28	Coperchietto paragrasso posteriore interno	28	Inner rear side grease-guard cover
29	Coperchietto paragrasso posteriore esterno	29	Outer rear side grease-guard cover
30	Ingrassatore "Tecalamit"	30	"Tecalamit" lubricator
31	Valvola rotante anteriore	31	Front side grease slinger
32	Valvola rotante posteriore	32	Rear side grease slinger
33	Ghiera di bloccaggio	33	Ring nut
34	Rosetta di sicurezza	34	Locking washers
35	Coperchietto valvola a grasso	35	Grease slinger cover
36	Ventola di raffreddamento interna	36	Inner cooling fan
37	Coprimorsettiera ausiliari	37	Auxiliary terminal box

Denominazione Componenti

Name of Components

Serie CS - Forma V1
Grandezza 355÷500

CS Series - Mounting V1
Frame 355÷500

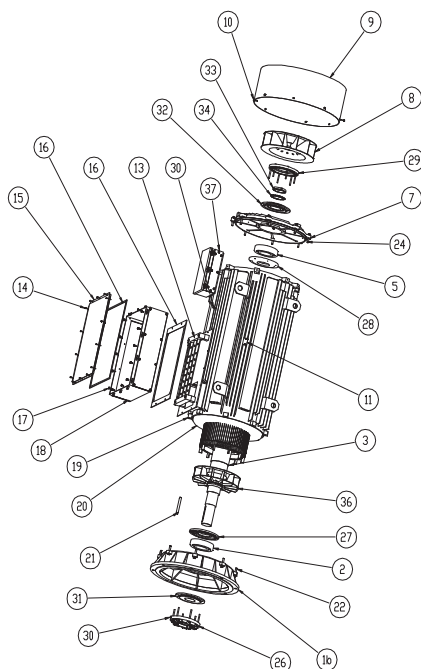

1b	Flangia B5	1b	Front shield with flange B5
2	Cuscinetto anteriore	2	Front bearing
3	Albero con rotore	3	Shaft with rotor
5	Cuscinetto posteriore	5	Rear bearing
7	Scudo posteriore	7	Rear shield
8	Ventola di raffreddamento	8	Cooling fan
9	Copriventola	9	Fan cover
10	Vite fissaggio copriventola	10	Fixing screw for fan cover
11	Targa dati motore	11	Rating plate
13	Morsettiera	13	Terminal board
14	Vite fissaggio coperchio coprimorsettiera	14	Fixing screw for terminal box cover
15	Coperchio coprimorsettiera	15	Terminal box cover
16	Guarnizione coprimorsettiera	16	Gasket
17	Vite fissaggio coprimorsettiera	17	Fixing screw for terminal box
18	Coprimorsettiera	18	Terminal-box
19	Carcassa con statore	19	Frame with stator package
20	Avvolgimento	20	Winding
21	Chiavetta lato accoppiamento	21	Coupling side key
22	Vite fissaggio flangia/scudo - carcassa	22	Fixing screw for shield/flange
24	Vite fissaggio scudo - carcassa	24	Fixing screw for shield
26	Coperchietto paragrasso anteriore esterno	26	Inner front side grease-guard cover
27	Coperchietto paragrasso anteriore interno	27	Outer front side grease-guard cover
28	Coperchietto paragrasso posteriore interno	28	Inner rear side grease-guard cover
29	Coperchietto paragrasso posteriore esterno	29	Outer rear side grease-guard cover
30	Ingrassatore "Tecalamit"	30	"Tecalamit" lubricator
31	Valvola rotante anteriore	31	Front side grease slinger
32	Valvola rotante posteriore	32	Rear side grease slinger
33	Ghiera di bloccaggio	33	Ring nut
34	Rosetta di sicurezza	34	Locking washers
36	Ventola interna	36	Inner cooling fan
37	Coprimorsettiera ausiliari	37	Auxiliary terminal box

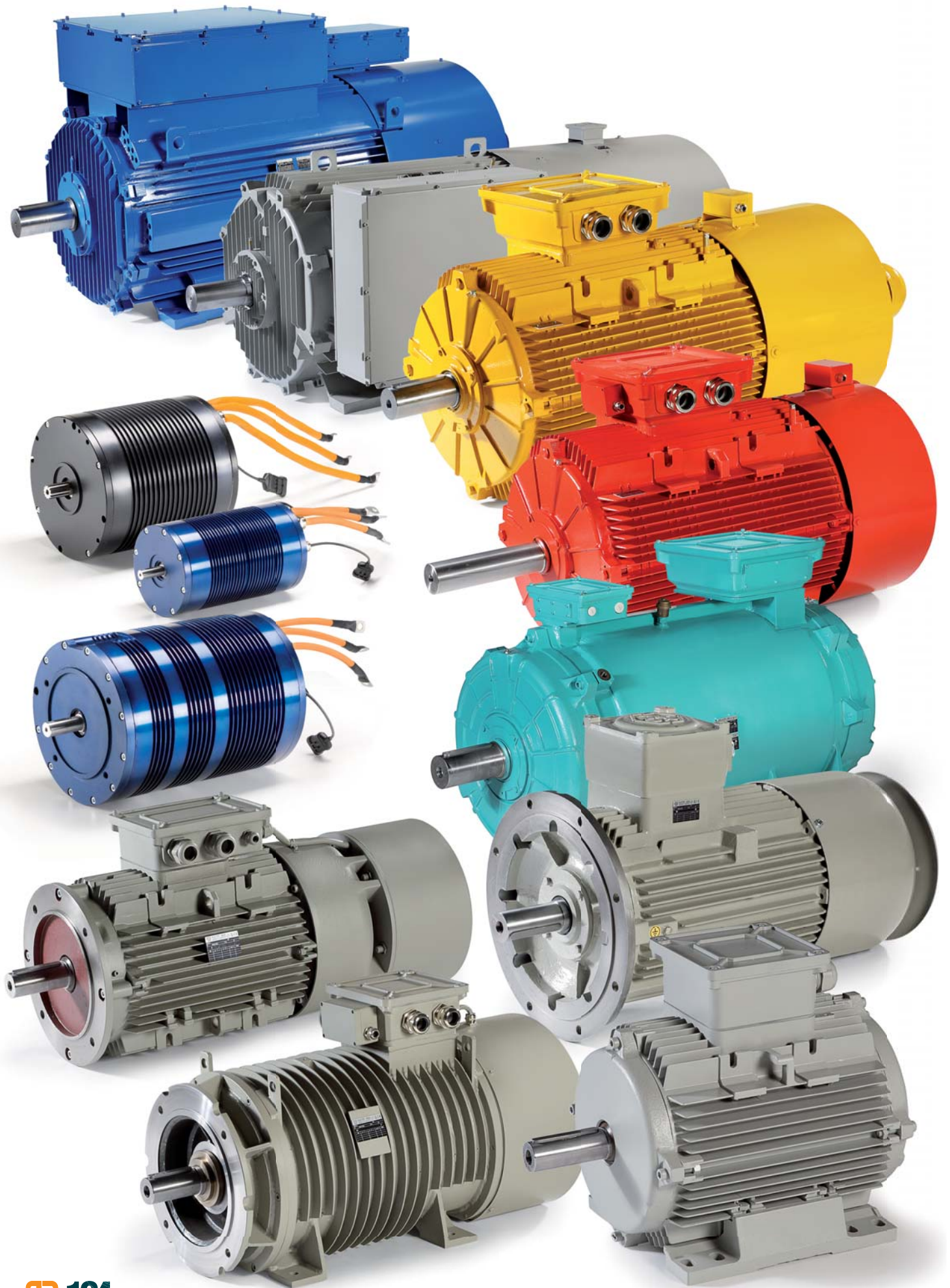

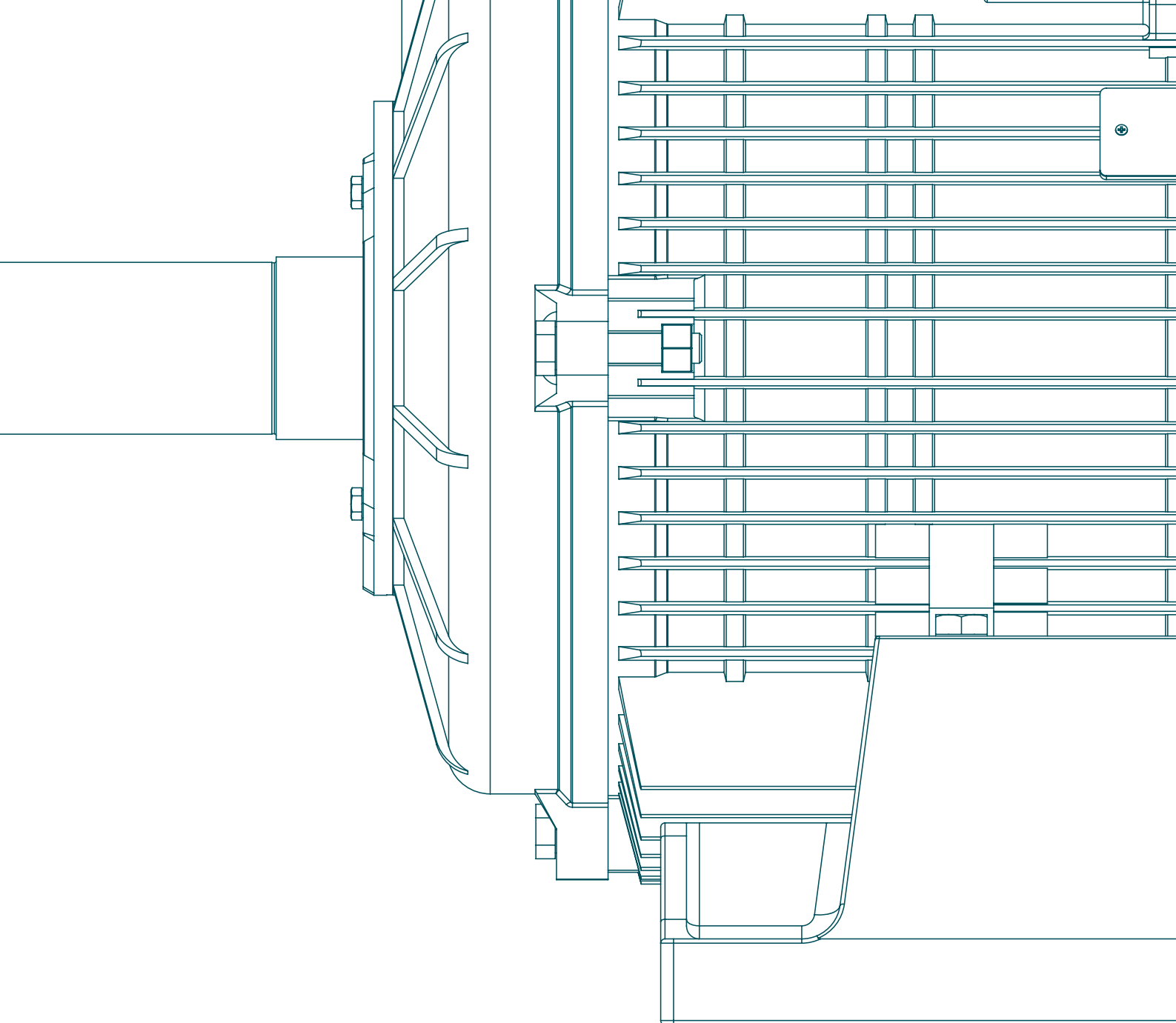

 **ELECTRO ADDA**[®]
il motore che fa la differenza

Electro Adda S.p.A.

Via Nazionale, 8 - I 23883 Beverate di Brivio LC

tel. +39 039 53.20.621 - fax +39 039 53.21.335 - www.electroadda.com - info@electroadda.com

Via S. Anna, 640 - I 41122 Modena MO

tel. +39 059 45.21.32 - fax +39 059 45.21.58 - commerciale.modena@electroadda.com

