

## TOK COUPLING SYSTEM

Highly Flexible Coupling Shaft for Test Benches

[www.reich-kupplungen.com](http://www.reich-kupplungen.com)



SIMPLY **POWERFUL.**





## D2C – Designed to Customer

The guiding principle of Designed to Customer is the recipe for success behind REICH. In addition to the catalogue products, we supply our customers with couplings developed to their specific requirements. The designs are mainly based on modular components to provide effective and efficient customer solutions. The special nature of our close cooperation with our partners ranges from; consulting, development, design, manufacture and integration to existing environments, to customer-specific production, logistics concepts and after-sales service - worldwide.

This customer-oriented concept applies to both standard products and production in small batch sizes.

The company policy at REICH embraces, first and foremost, principles such as customer satisfaction, flexibility, quality, prompt delivery and adaptability to the requirements of our customers.

REICH provides you with not only a coupling, but a solution:

Designed to Customer – SIMPLY **POWERFUL**.

**D2C**  
Designed to Customer



# TOK COUPLING SYSTEM

## Contents

### Coupling Information

- 04** General Technical Description
- 05** Advantages
- 06** Standard Types
- 08** Special Types
- 10** Technical Layout
- 12** General Technical Data
- 13** Selection of the Coupling Size
- 24** Adapter Dimension Tables
- 26** Data Required for Coupling Size Selection

### Dimension Tables

- 14** Type - S - CV
- 16** Type - B - CS
- 18** Type - S - I
- 20** Type - S
- 22** Type - B

# TOK COUPLING SYSTEM

## General Technical Description

### TOK COUPLING SYSTEM

#### Highly Flexible Coupling Shafts for Test Benches

Test benches have a wide variety of applications in power transmission engineering. They are used to determine properties of test objects in research, development, manufacturing and quality assurance. The drive train components which are predominantly tested on test benches include, but are not limited to, engines, gearboxes, transmission elements and consumables. Given the multitude of testing tasks, the specific requirements for couplings on test benches are quite diverse. The TOK coupling system can be used in almost all applications, and on test benches in particular. The wide range of flexible coupling elements, adaptations and connection shafts ensures that a standard solution is almost always available in a wide variety of different tasks. These can be complemented by specific customised designs on request.

The flexible element is designed to combine high torque transmission capacity with high speed capability. Its torsional stiffness can be adapted to requirements by selecting different types of rubber.

Bearings or integrated joints support the loads arising from the connection between the drive end and the output end. Cardan shafts, constant velocity (CV) shafts and compact shafts are available as connections which also compensate for displacements. Adaptive designs are based on the standard DIN or SAE flange connection dimensions, the CV shaft joints and the torque measuring flanges. The couplings cover a torque range from approx. 100 Nm at 10 000 min<sup>-1</sup> up to 70 000 Nm at 1 800 min<sup>-1</sup>.

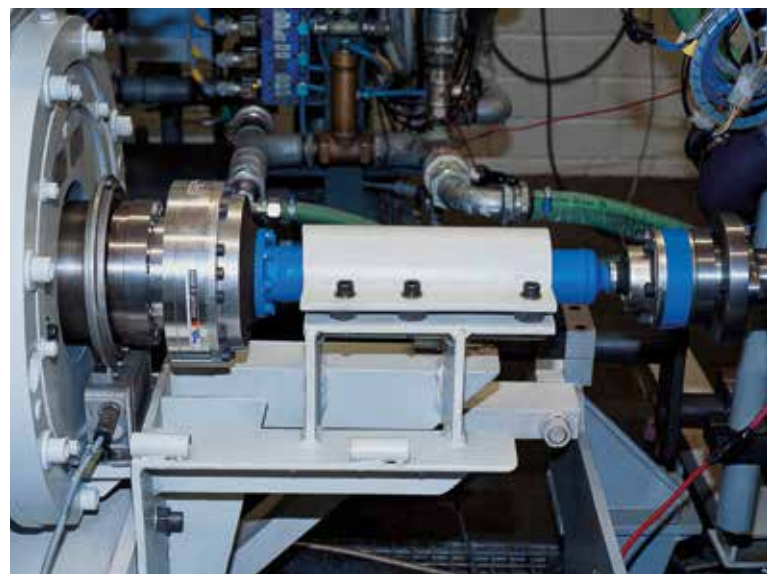

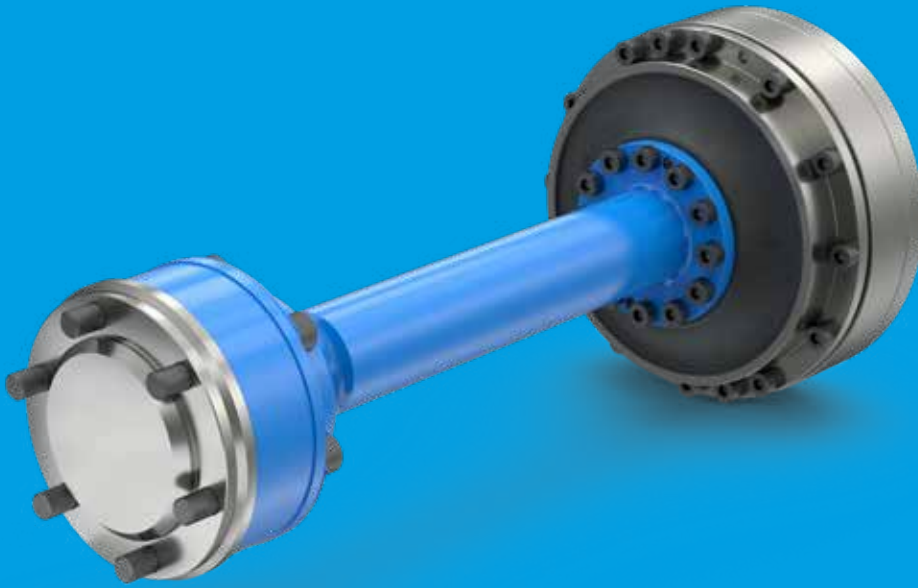

## TOK

Nominal torques from approx. 100 Nm at 10 000 min<sup>-1</sup>  
to 70 000 Nm at 1800 min<sup>-1</sup>

## TOK COUPLING SYSTEM

### Advantages

#### Salient features and advantages of the highly flexible TOK COUPLING SYSTEMS:

- Elements available in different dynamic torsional stiffnesses
- Suited for highest speeds
- Adaptation to DIN or SAE flanges or according to specification
- Self-centering, backlash-free and maintenance-free
- Optional reduction of the torsional stiffness through the use of 2 elements
- Compensation of axial, radial and angular displacements
- Light-weight construction through the use of high-strength aluminium
- Variable mounting lengths through telescopic intermediate shafts
- For use up to  $T_{KN}$ , depending on the application

# TOK

## Standard Types

Type - S - CV



- Constant velocity shaft CV (one joint)
- Telescopic length and displacement compensation
- For highest speeds
- Little weight to be supported
- Adapters matched to DIN, SAE or CV
- Adapters for the engine and brake sides

Type - B - CS

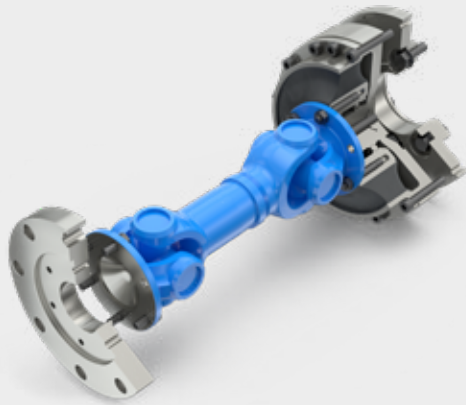

- Cardan shaft with DIN connection
- Telescopic length and displacement compensation
- Adapters matched to DIN, SAE or CV
- Adapters for the engine and brake sides
- Easy bolting of the cardan shaft by means of stay bolts and nuts

Type - S - I



- Intermediate shaft, compact design
- Large telescopic length and displacement compensation
- Little weight to be supported
- For highest speeds
- Adapters matched to DIN, SAE or CV
- Adapters for the engine and brake sides

## Type - S



- Short design
- Integrated spherical bearing for angular displacement compensation
- For intermediate shafts similar to S-CV
- For highest speeds
- Little weight to be supported
- Adapter-mounted

## Type - B



- Short design with DIN connection on the drive end
- Integrated rolling bearing arrangement
- For highest speeds
- For cardan shaft
- Adapter-mounted CV shaft
- Stay bolts for direct cardan shaft connection

# TOK

## Special Types

Compact shaft in extra short design

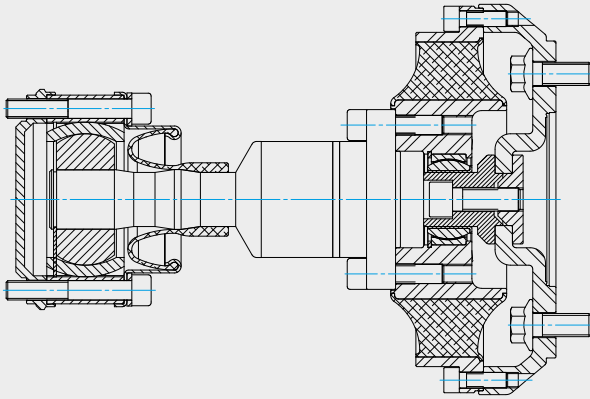

- Extremely short design
- Compact connecting flange
- Constant velocity shaft CV
- Minimum weight to be supported

Docking System Illustration with H-Flanges

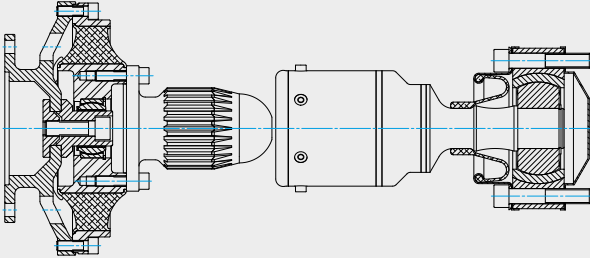

- Easy handling
- For multiple test cells
- Minimised rigging times
- Freely pluggable
- Combinable for different engines
- Short mounting length option
- Large telescopic length option

With CV shaft of extra short design

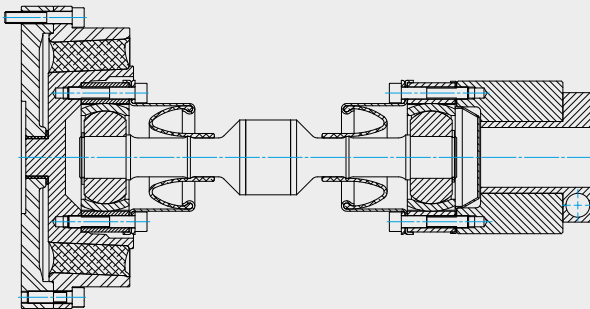

- Extremely short design
- CV shaft joint integrated in the coupling
- Constant velocity shaft CV
- Compact connecting flange
- Shaft connection with hydraulic clamping bush



### With reinforced bearing

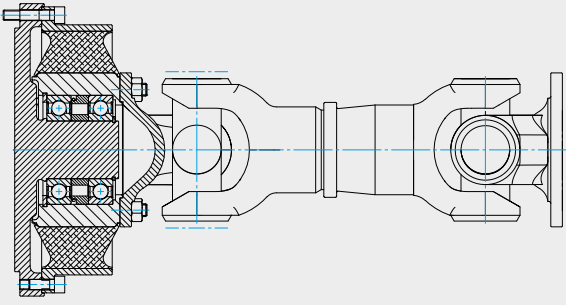

- Increased speeds possible
- High speeds possible with CV shafts
- Increased displacements possible

### Type AC-VSK - Heavy-Duty

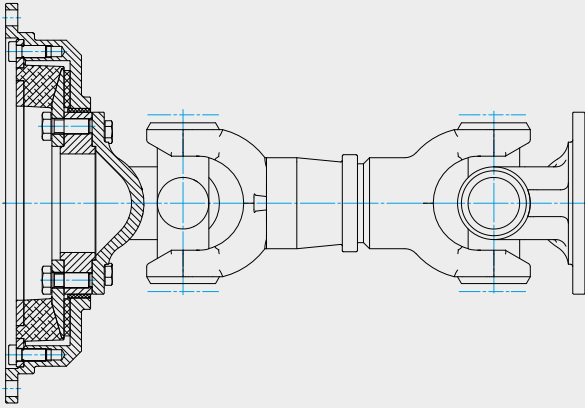

- U-joint coupling for cardan shaft
- Highly flexible rubber element
- Integral bearing
- Frictional damping
- Robust design

# TOK

## Technical Layout

### Design and Function

The highly flexible, torsionally optimised TOK couplings are specifically designed for use on test benches.

Radial and axial loads are supported by the bearing arrangement (2) towards the output end. Low-backlash spherical bearings (2a) centre the ends relative to each other in a true running manner. Alternatively, the spherical bearings (TOK-S) can be replaced by an integrated rolling bearing (TOK-B) (2b). The highly flexible coupling element (3) is designed as a rubber-metal bond between

the inner sleeve (3a), the rubber element (3b) and the outer ring (3c). When torque acts on the drive side, the flexibility of the rubber element enables relative twisting against the output side. Torsional vibrations from the drive are thus efficiently de-coupled from the output side.

Besides the standard types customised special solutions can also be realised with the TOK coupling systems.

### TOK layout and materials

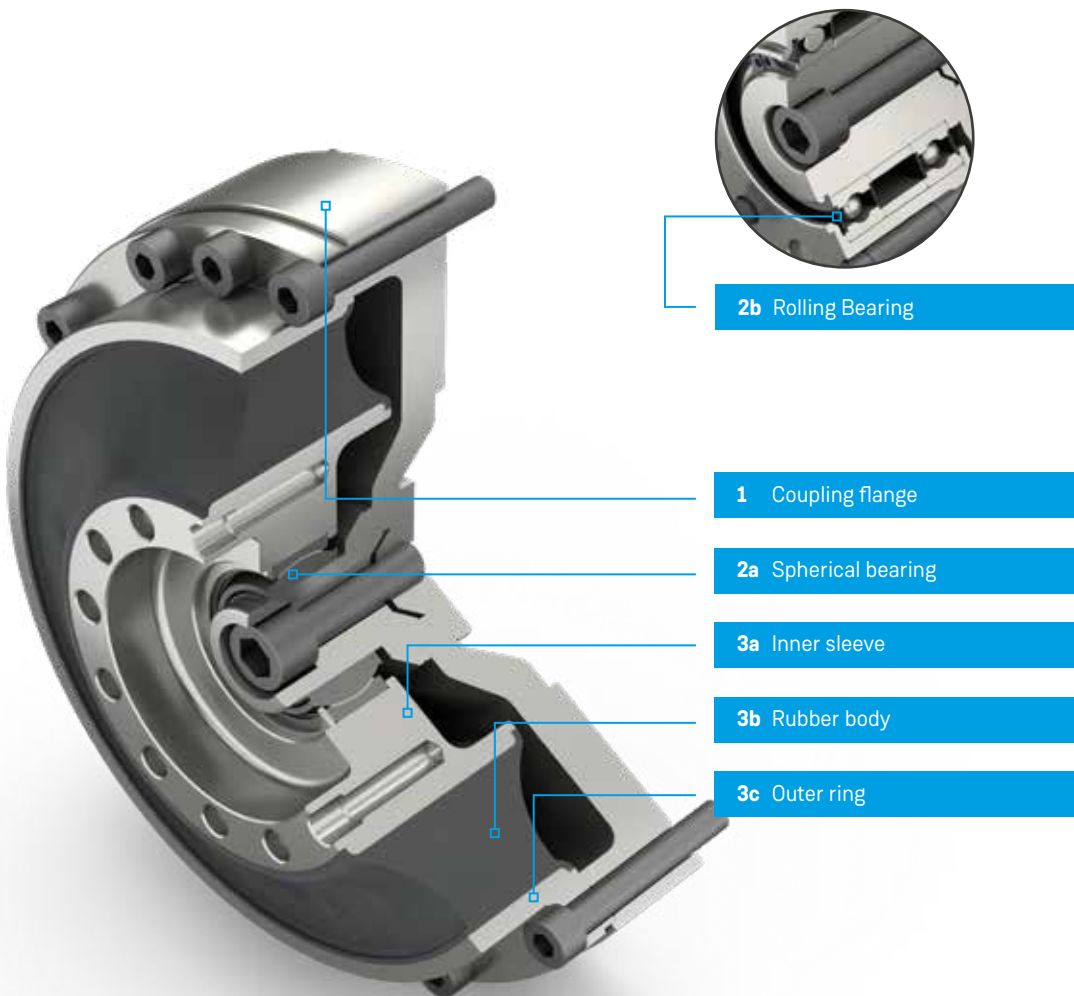

# TOK

## Materials

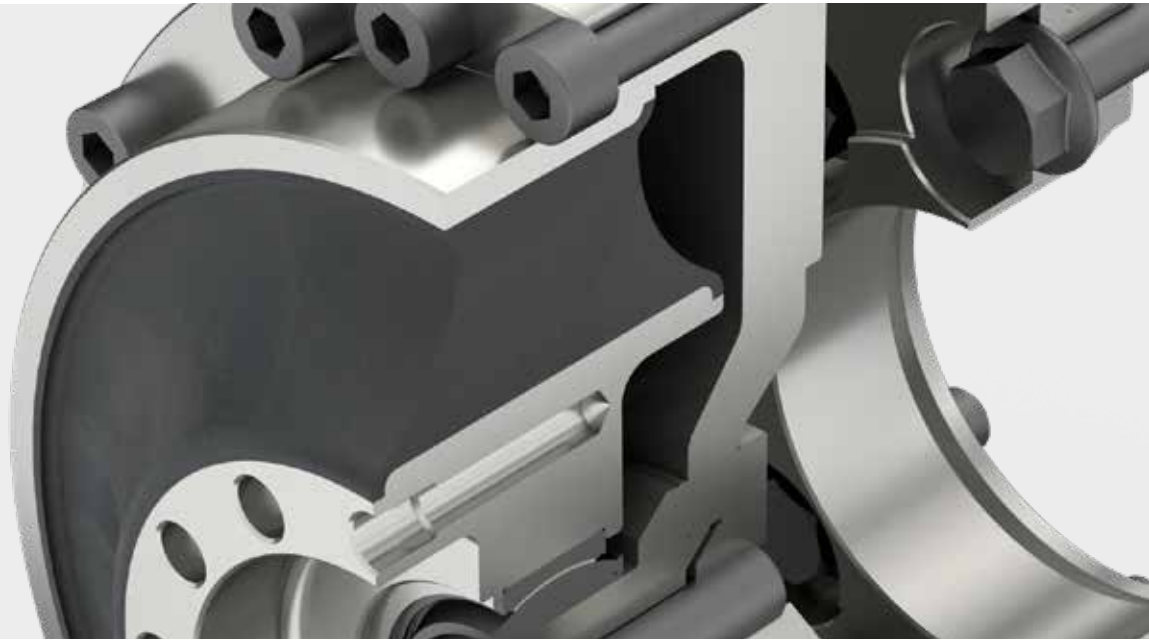

### Materials Overview

Part No.	Designation	Materials
1	Coupling flange, output side	High-strength aluminium
2	Bearing arrangement	-
2a	Spherical bearing	Steel (maintenance-free)
2b	Rolling Bearing	Composite material (maintenance-free)
3	Flexible element	-
3a	Inner sleeve	High-strength aluminium/steel
3b	Rubber body	Rubber according to general technical data
3c	Outer ring	High-strength aluminium/steel

### Technical Note

The technical data applies only to the complete coupling or the corresponding coupling elements. It is the customer's/user's responsibility to ensure there are no inadmissible loads acting on any of the components. In particular, existing connections, e.g. bolted connections, must be checked with regard to the torques to be transmitted. If necessary, further measures, such as additional reinforcement with pins, may be necessary. It is the customer's/user's responsibility to make sure the dimensioning of the shaft and keyed or other connection, e.g. shrinking or clamping connection,

is correct. All components that can rust are protected against corrosion as standard.

REICH have an extensive range of couplings and coupling systems to cover nearly every drive configuration. Customized solutions can be developed and manufactured even in small batches or as prototypes. In addition calculation programs are available for all necessary dimensioning.

# TOK

## General Technical Data



### Standard Type

Coupling size	Nominal torque	Maximum torque	Continuous fatigue torque	Dynamic Torsional Stiffness <sup>1) 4)</sup>	Permissible power loss <sup>2)</sup>	Maximum speed
	$T_{KN}$ [Nm]	$T_{Kmax}$ [Nm]	$T_{KW}$ (10 Hz) [Nm]	$C_{T dyn}$ [Nm/rad]	$P_{KV}$ (30°) [W]	$n_{max}$ [min <sup>-1</sup> ]
TOK 100 - 135 <sup>4)</sup>	100	250	60	135	50	10000
TOK 250 - 280	250	625	80	280	45	10000
TOK 350 - 600	350	875	135	600	60	10000
TOK 500 - 1050	500	1250	170	1050	60	10000
TOK 600 - 1150	600	1500	200	1150	70	10000
TOK 700 - 1500	700	1750	230	1500	70	10000
TOK 1000 - 2400	1000	2500	330	2400	90	10000
TOK 1600 - 4800	1600	4000	510	4800	100	8000
TOK 2200 - 5300	2200	5500	690	5300	180	6000
TOK 3400 - 11000	3400	8500	1000	11000	180	5000
TOK 5000 - 11500	5000	12500	1650	11500	450	5000
TOK 8000 - 24000 <sup>3)</sup>	8000	20000	2500	24000	500	4000
TOK 18000 - 56000 <sup>3)</sup>	18000	45000	5400	56000	1000	3500
TOK 35000 - 140000 <sup>3)</sup>	35000	87500	8750	140000	1000	3000
TOK 70000 - 360000 <sup>3)</sup>	70000	175000	22000	360000	2500	1800

- i** 1) For versions with 2 rubber elements (series connection) the following applies  $\frac{C_{Tdyn}}{2}$
- 2) Permissible power loss up to 1 hour
- 3) Coupling dimensions and data on request
- 4) The stiffness may deviate by up to 20% due to manufacturing and material tolerances according to DIN 53505

### Shore hardness Sh A and relative damping $\Psi$

Element version	Sh A	$\Psi$
HN	48	0.40

- i** Due to the physical properties of the rubber material, the measurable rubber hardness is subject to a variation that is defined as  $\pm 5^\circ$  Shore A according to DIN 53505. However, this variation is minimized by our own rubber production.
- Other version on request.

# TOK

## Selection of the Coupling Size

In selecting the coupling size the following should be satisfied:

**The nominal torque of the coupling  $T_{KN}$**  must be taken into account at every temperature and operating load of the coupling, whilst observing the service factors S (e.g: temperature factor  $S_t$ ) shall be at least equal to the maximum nominal torque on the drive side  $T_{AN}$ ; the temperature in the immediate vicinity of the coupling must be taken into account.

$$T_{KN} \geq T_{AN} \cdot S_t \cdot S_B$$

A safety factor of  $S_M = 1.3$  should be applied if the coupling size is pre-selected based on the continuous engine power to be transmitted. For the layout, it is recommended to consider the nominal **engine drive torque  $T_{AN}$**  and the maximum coupling torque occurring in operation. The coupling size selection for test bench applications should be verified by a torsional vibration analysis which we will conduct on request. For compiling the details, please use the sheet "Details for coupling selection and torsional vibration analysis" on the last page. For long test bench shafts, the bending critical speed may also have to be taken into account. In principle, it is the responsibility of the operator to comply with the safety regulations applicable to the specific use.

$$T_{AN} [Nm] = 9550 \frac{P [kW]}{n [min^{-1}]} \cdot S_M$$

The **temperature factor  $S_t$**  allows for the decreasing load capacity of the coupling when affected by elevated ambient temperatures in the vicinity of the coupling.

Temperature t	60 °C	70 °C	80 °C	>80 °C
$S_t$	1.25	1.4	1.6	on request

A continuous torsional vibration analysis to verify the coupling selection should confirm that the permissible **continuous fatigue torque  $T_{KW}$**  is at least equal to the highest fatigue torque  $T_W$  under reversing stresses encountered throughout the operating speed range while taking into account the temperature and frequency.

$$T_{KW} (10 \text{ Hz}) \geq T_W \cdot S_f \cdot S_t$$

The **frequency factor  $S_f$**  allows for the frequency dependence of the permissible continuous fatigue torque under reversing stresses  $T_{KW} (10 \text{ Hz})$  with an operating frequency  $f_x$ .

$$S_f = \sqrt{\frac{f_x}{10}}$$

Take care not to continuously operate the system at the resonance frequency of the test bench to avoid damage to the coupling, the test objects and the test bench components.

# TOK

## Type - S - CV

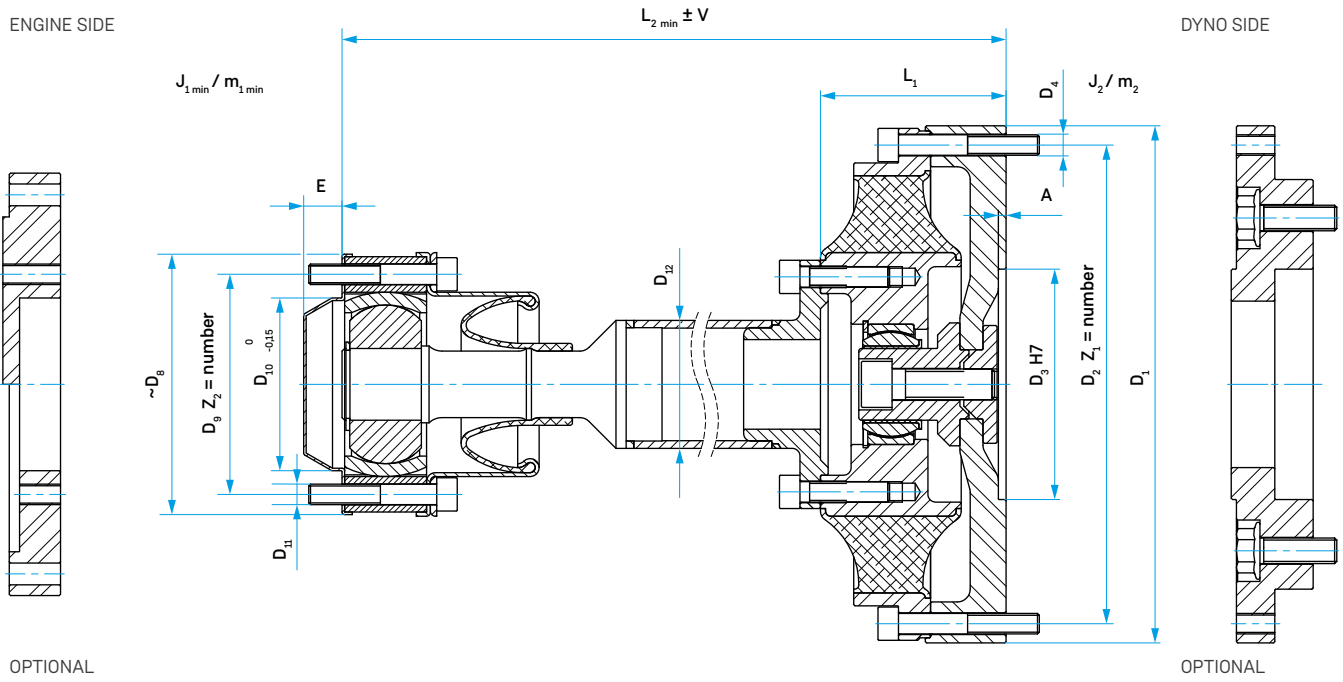

**i** For adapter dimensions see page 24

## Coupling dimensions, drive side and output side

Coupling size	CV connection											
	D <sub>8</sub> [mm]	D <sub>9</sub> [mm]	Z <sub>2</sub>	D <sub>11</sub>	D <sub>10</sub> [mm]	E [mm]	D <sub>1</sub> [mm]	D <sub>2</sub> [mm]	Z <sub>1</sub>	D <sub>4</sub>	D <sub>3</sub> [mm]	A [mm]
250-280	103	86.0	6	M8	67.5	15	182	170.0	12	M6	90	3
350-600	103	86.0	6	M8	67.5	15	168	156.0	12	M6	90	3
500-1050	103	86.0	6	M8	67.5	15	202	187.0	12	M8	90	3
600-1150	103	86.0	6	M8	67.5	15	202	187.0	12	M8	90	3
700-1500	103	86.0	6	M8	67.5	15	202	187.0	12	M8	90	3
1000-2400	111	94.0	6	M10	81.0	16	228	210.0	12	M8	90	3
1600-4800	131	108.0	6	M12	90.0	20	269	252.0	12	M8	90	3
2200-5300	131	108.0	6	M12	90.0	20	305	286.0	12	M8	90	3
3400-11000	150	128.0	6	M12	112.0	25	373	345.0	12	M12	90	3
5000-11500	188	155.5	6	M16	136.0	26	472	438.2	16	M12	140	3

## Coupling details

Coupling size	L <sub>1</sub> [mm]	L <sub>2 min</sub> <sup>1)</sup> [mm]	D <sub>12</sub> [mm]	Joint size CV shaft	V [mm]	J <sub>1 min</sub> [kgm <sup>2</sup> ]	m <sub>1 min</sub> [kg]	J <sub>2</sub> [kgm <sup>2</sup> ]	m <sub>2</sub> [kg]
250-280	71	277	50	CV13	11.0	0.0040	2.6	0.0100	3.8
350-600	64	231	50	CV13	11.0	0.0043	2.4	0.0070	3.4
500-1050	73	240	50	CV13	11.0	0.0060	2.4	0.0180	5.3
600-1150	78	245	50	CV13	11.0	0.0062	2.4	0.0180	5.3
700-1500	86	253	50	CV13	11.0	0.0065	2.5	0.0190	5.5
1000-2400	85	255	60	CV15	8.0	0.0120	3.2	0.0260	6.6
1600-4800	86	264	70	CV21	12.0	0.0260	5.1	0.0500	9.3
2200-5300	99	277	70	CV21	12.0	0.0370	5.2	0.0960	14.0
3400-11000	100	348	90	CV30	12.5	0.0920	8.4	0.2100	23.0
5000-11500	130	415	100	CV32	12.5	0.1800	13.0	0.6300	35.0

 1) Alternative lengths on request

## Ordering example

Coupling size	Dynamic torsional stiffness of the coupling	Bearing version (S = spherical bearing)	Constant velocity shaft size	Total length of the coupling without adapter (L <sub>2</sub> )
TOK600	- 1150 -	S -	CV13 -	245

 Coupling designation: TOK600 - 1150 - S - CV13 - 245

# TOK

## Type - B - CS

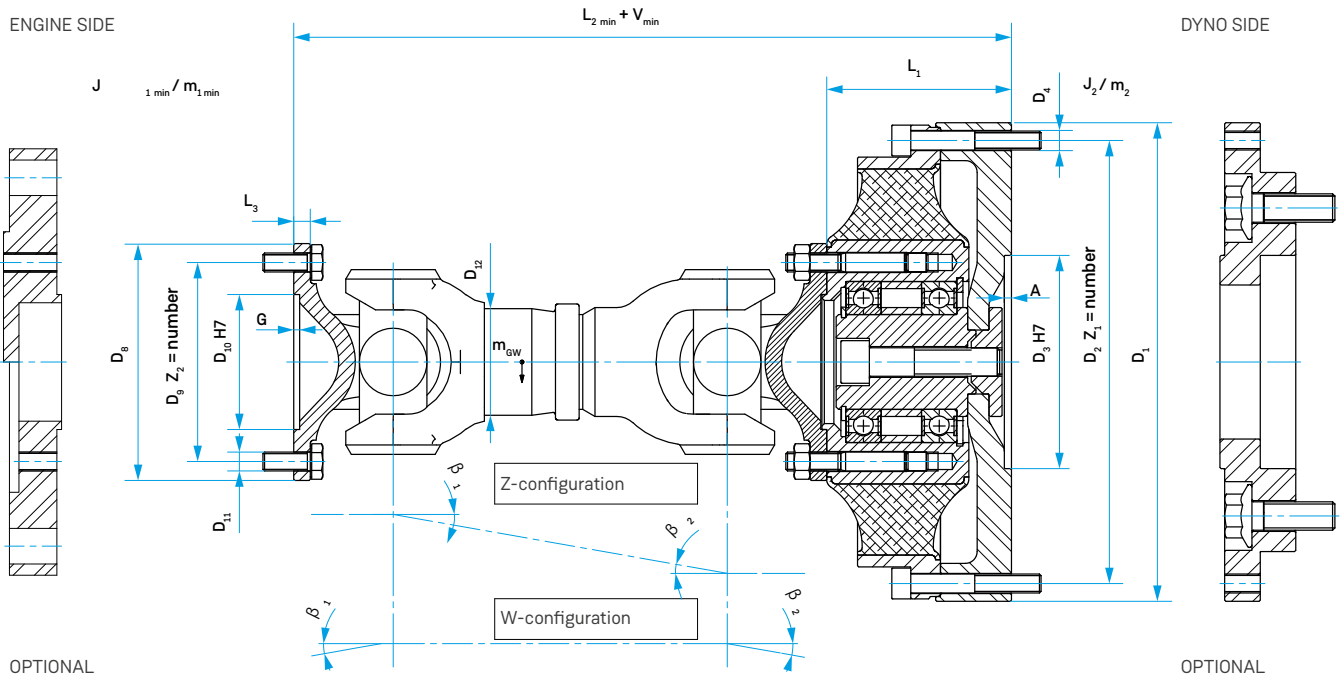

**i** For adapter dimensions see page 24



## Coupling dimensions, drive side and output side

Coupling size	DIN connection											
	D <sub>8</sub> [mm]	D <sub>9</sub> [mm]	Z <sub>2</sub>	D <sub>11</sub>	D <sub>10</sub> [mm]	G [mm]	D <sub>1</sub> [mm]	D <sub>2</sub> [mm]	Z <sub>1</sub>	D <sub>4</sub>	D <sub>3</sub> [mm]	A [mm]
250-280	100	84.0	6	M8	57	2.5	182	170.0	12	M6	90	3
350-600	90	74.5	4	M8	47	2.5	168	156.0	12	M6	90	3
500-1050	100	84.0	6	M8	57	2.5	202	187.0	12	M8	90	3
600-1150	100	84.0	6	M8	57	2.5	202	187.0	12	M8	90	3
700-1500	100	84.0	6	M8	57	2.5	202	187.0	12	M8	90	3
1000-2400	120	101.5	8	M10	75	2.5	228	210.0	12	M8	90	3
1600-4800	150	130.0	8	M12	90	3.0	269	252.0	12	M8	90	3
2200-5300	150	130.0	8	M12	90	3.0	305	286.0	12	M8	90	3
3400-11000	180	155.5	8	M16	110	3.6	373	345.0	12	M12	90	3
5000-11500	180	155.5	10	M16	110	3.6	472	438.2	16	M12	140	3

## Coupling details

Coupling size	L <sub>1</sub> [mm]	L <sub>2 min</sub> <sup>1) 2)</sup> [mm]	L <sub>3</sub> [mm]	D <sub>12</sub> [mm]	V <sub>min</sub> <sup>2)</sup> [mm]	J <sub>1 min</sub> <sup>2)</sup> [kgm <sup>2</sup> ]	m <sub>1</sub> <sup>2)</sup> [kg]	J <sub>2</sub> [kgm <sup>2</sup> ]	m <sub>2</sub> <sup>2)</sup> [kg]	n <sub>max</sub> <sup>3)</sup> [min <sup>-1</sup> ]
250-280	92	325	7	50	17	0.0053	2.0	0.0100	6.4	7000
350-600	64	297	6	50	17	0.0046	1.9	0.0070	5.5	7000
500-1050	73	336	7	50	22	0.0086	2.5	0.0180	8.5	7000
600-1150	78	341	7	50	22	0.0090	2.5	0.0190	8.8	7000
700-1500	86	349	7	50	22	0.0100	2.5	0.0190	9.6	7000
1000-2400	82	435	9	70	27	0.0260	5.6	0.0250	15.0	5500
1600-4800	86	454	10	80	32	0.0590	7.8	0.0510	22.0	4500
2200-5300	99	507	12	90	42	0.0980	10.0	0.0970	30.0	4000
3400-11000	100	578	14	110	47	0.2500	18.0	0.2100	51.0	2500
5000-11500	140	618	14	110	47	0.3800	18.0	0.7600	77.0	2300

- i** 1) Alternative lengths/telescopic lengths on request  
 2) Shortest mounting length which can be pushed together by at least another 8 mm  
 3) The maximum speed exclusively applies to the design as shown. For the speed reduction for other cardan shafts, see page 24. Alignment  $\beta_1 = \beta_2 \leq 1^\circ$ . Cardan shaft with a balancing grade of G 6.3 according to DIN ISO 21940

## Ordering example

Coupling size	Dynamic torsional stiffness of the coupling	Bearing version (B = rolling bearing)	DIN connection of the cardan shaft	Total length of the coupling without adapter (L <sub>2</sub> )	Telescopic length of the coupling
TOK600	- 1150 -	B -	CS100 -	341 -	V22

Coupling designation: TOK600 - 1150 - B - CS100 - 341 - V22

# TOK

## Type - S - I

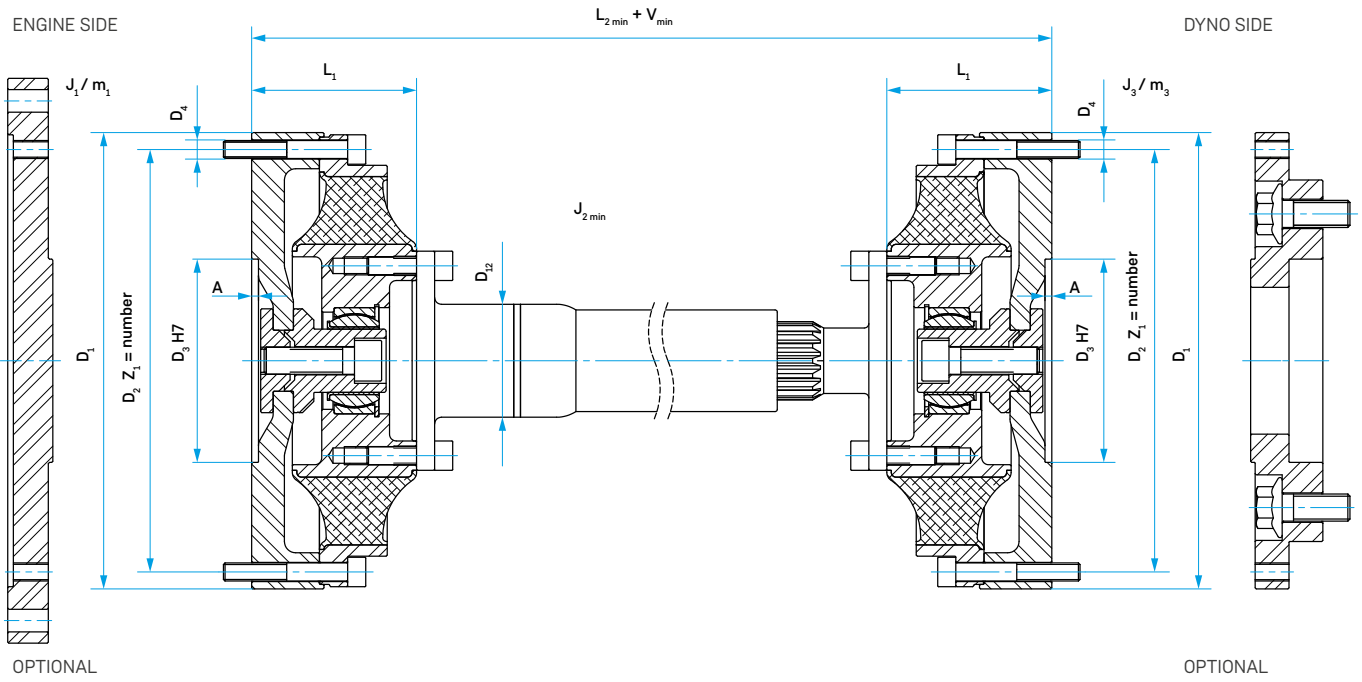

**i** For adapter dimensions see page 24

## Coupling dimensions, drive side and output side

Coupling size	D <sub>1</sub> [mm]	D <sub>2</sub> [mm]	Z <sub>1</sub>	D <sub>4</sub>	D <sub>3</sub> [mm]	A [mm]
250-140	182	170.0	12	M6	90	3
350-300	168	156.0	12	M6	90	3
500-525	202	187.0	12	M8	90	3
600-575	202	187.0	12	M8	90	3
700-750	202	187.0	12	M8	90	3
1000-1200	228	210.0	12	M8	90	3
1600-2400	269	252.0	12	M8	90	3
2200-2650	305	286.0	12	M8	90	3
3400-5500	373	345.0	12	M12	90	3
5000-5750	472	438.2	16	M12	140	3

## Coupling details

Coupling size	L <sub>1</sub> [mm]	L <sub>2 min</sub> <sup>1) 2)</sup> [mm]	D <sub>12</sub> [mm]	V <sub>min</sub> <sup>1)</sup> [mm]	J <sub>1</sub> [kgm <sup>2</sup> ]	m <sub>1</sub> <sup>2)</sup> [kg]	J <sub>2 min</sub> <sup>2)</sup> [kgm <sup>2</sup> ]	J <sub>3</sub> [kgm <sup>2</sup> ]	m <sub>3</sub> <sup>2)</sup> [kg]
250-140	71	320	40	32	0.0100	3.6	0.0020	0.0100	3.7
350-300	64	328	40	32	0.0070	3.4	0.0028	0.0070	3.6
500-525	73	374	50	32	0.0180	5.5	0.0065	0.0180	5.8
600-575	78	384	50	32	0.0180	5.5	0.0069	0.0180	6.0
700-750	86	400	50	32	0.0190	6.0	0.0076	0.0190	6.3
1000-1200	85	448	70	32	0.0260	7.9	0.0160	0.0260	8.9
1600-2400	86	450	80	32	0.0500	11.0	0.0340	0.0500	12.0
2200-2650	99	596	90	32	0.0960	17.0	0.0610	0.0960	19.0
3400-5500	100	558	100	32	0.2100	25.0	0.1500	0.2100	27.0
5000-5750	130	618	110	32	0.6300	39.0	0.2700	0.6300	42.0

**i** 1) Alternative lengths/telescopic lengths on request

2) Shortest mounting length

## Ordering example

Coupling size	Dynamic torsional stiffness of the coupling	Bearing version (S = spherical bearing)	Telescopic shaft as spacer	Total length of the coupling without adapter (L <sub>2</sub> )	Telescopic length of the coupling
TOK600	- 575 -	S -	I -	384 -	V32

Coupling designation: TOK600 - 575 - S - I - 384 - V32

# TOK

Type - S

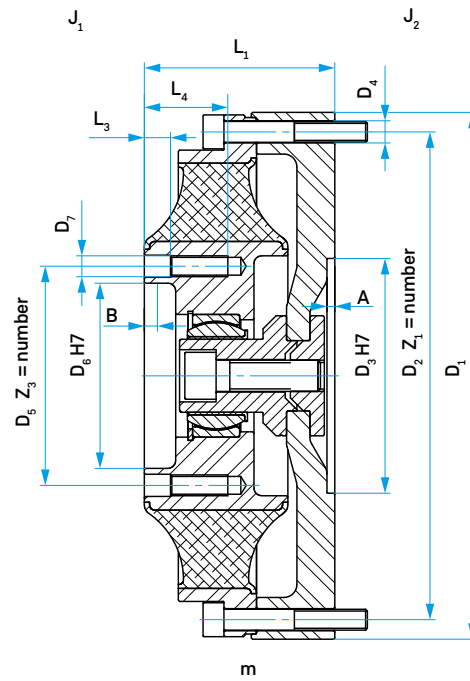

## Coupling dimensions, drive side and output side

Coupling size	D <sub>5</sub> [mm]	Z <sub>3</sub>	D <sub>7</sub>	D <sub>6</sub> [mm]	D <sub>1</sub> [mm]	D <sub>2</sub> [mm]	Z <sub>1</sub>	D <sub>4</sub>	D <sub>3</sub> [mm]
250-280	56.0	12	M6	43	182	170.0	12	M6	90
350-600	66.0	8	M8	53	168	156.0	12	M6	90
500-1050	84.0	12	M8	71	202	187.0	12	M8	90
600-1150	84.0	12	M8	71	202	187.0	12	M8	90
700-1500	84.0	12	M8	71	202	187.0	12	M8	90
1000-2400	101.5	12	M10	75	228	210.0	12	M8	90
1600-4800	108.0	12	M12	85	269	252.0	12	M8	90
2200-5300	130.0	12	M12	104	305	286.0	12	M8	90
3400-11000	155.5	10	M16	110	373	345.0	12	M12	90
5000-11500	155.5	14	M16	110	472	438.2	16	M12	140

## Coupling details

Coupling size	L <sub>1</sub> [mm]	L <sub>3</sub> [mm]	L <sub>4</sub> [mm]	A [mm]	B <sub>min</sub> [mm]	J <sub>1</sub> [kgm <sup>2</sup> ]	J <sub>2</sub> [kgm <sup>2</sup> ]	m [kg]
250-280	71	9	23	3	5	0.0007	0.0100	2.8
350-600	64	10	26	3	5	0.0010	0.0073	2.6
500-1050	73	10	32	3	5	0.0021	0.0180	4.1
600-1150	78	10	32	3	5	0.0022	0.0180	4.2
700-1500	86	12	32	3	5	0.0025	0.0190	4.5
1000-2400	85	12	30	3	5	0.0042	0.0270	5.0
1600-4800	86	16	34	3	5	0.0120	0.0500	7.0
2200-5300	99	16	34	3	5	0.0200	0.0970	11.0
3400-11000	100	20	44	3	5	0.0530	0.2100	17.0
5000-11500	130	30	50	3	5	0.1000	0.6300	29.0

## Ordering example

Coupling size                      Dynamic torsional                      Bearing version  
Nominal torque of the coupling      stiffness of the coupling      (S = spherical bearing)

TOK600                      - 1150 -                      S

Coupling designation: TOK600 - 1150 - S

# TOK

Type - B

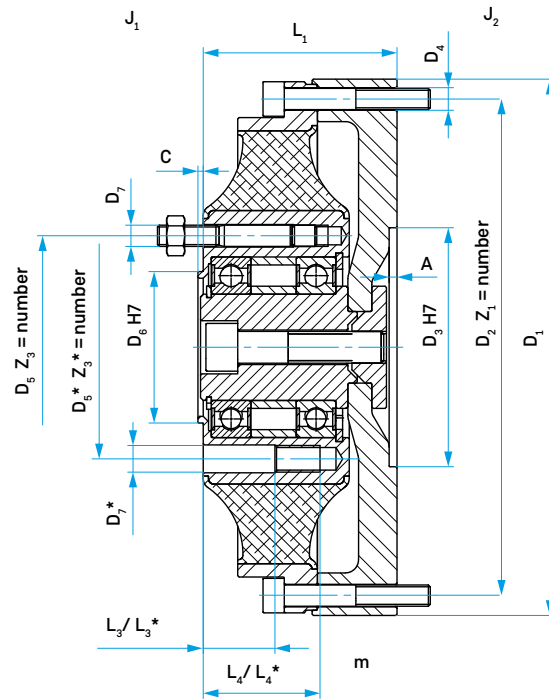

## Coupling dimensions, drive side and output side

Coupling size	D <sub>5</sub> [mm]	D <sub>5</sub> <sup>*</sup> [mm]	Z <sub>3</sub>	Z <sub>3</sub> <sup>*</sup>	D <sub>7</sub>	D <sub>7</sub> <sup>*</sup>	D <sub>6</sub> [mm]	D <sub>1</sub> [mm]	D <sub>2</sub> [mm]	Z <sub>1</sub>	D <sub>4</sub>	D <sub>3</sub> [mm]
250-280	84.0	-	6	-	M8	-	57	182	170.0	12	M6	90
350-600	74.5	74.5	4	4	M8	M8	47	168	156.0	12	M6	90
500-1050	84.0	84.0	6	6	M8	M10	57	202	187.0	12	M8	90
600-1150	84.0	84.0	6	6	M8	M10	57	202	187.0	12	M8	90
700-1500	84.0	84.0	6	6	M8	M10	57	202	187.0	12	M8	90
1000-2400	101.5	-	8	-	M10	-	75	228	210.0	12	M8	90
1600-4800	130.0	-	8	-	M12	-	90	269	252.0	12	M8	90
2200-5300	130.0	130.0	8	8	M12	M14	90	305	286.0	12	M8	90
3400-11000	155.5	-	8	-	M16	-	110	373	345.0	12	M12	90
5000-11500	155.5	-	10	-	M16	-	110	472	438.2	16	M12	140

 For the permissible speeds and attached weights see page 24

## Coupling details

Coupling size	L <sub>1</sub> [mm]	L <sub>3</sub> [mm]	L <sub>3</sub> <sup>*</sup> [mm]	L <sub>4</sub> [mm]	L <sub>4</sub> <sup>*</sup> [mm]	A [mm]	C [mm]	J <sub>1</sub> [kgm <sup>2</sup> ]	J <sub>2</sub> [kgm <sup>2</sup> ]	m [kg]
250-280	92	9.0	-	23	-	3	2.0	0.0024	0.0100	4.4
350-600	64	35.0	35.0	47	47	3	2.0	0.0022	0.0070	3.6
500-1050	73	33.9	30.3	47	55	3	2.0	0.0044	0.0180	5.8
600-1150	78	33.9	30.3	47	48	3	2.0	0.0048	0.0190	6.1
700-1500	86	33.9	30.3	47	48	3	2.0	0.0060	0.0190	6.9
1000-2400	82	30.3	-	48	-	3	2.0	0.0110	0.0250	8.7
1600-4800	86	37.4	-	56	-	3	2.5	0.0320	0.0510	14.0
2200-5300	99	35.3	33.5	58	58	3	2.5	0.0590	0.0970	20.0
3400-11000	100	39.9	-	66	-	3	3.0	0.1500	0.2100	32.0
5000-11500	140	39.9	-	65	-	3	3.0	0.2800	0.7600	58.0

## Ordering example

Coupling size                      Dynamic torsional                      Bearing version  
Nominal torque of the coupling      stiffness of the coupling      (S = spherical bearing)

TOK600                      - 1150 -                      B

 Coupling designation: TOK600 - 1150 - B

# TOK

## Adapter dimension tables

### Optional DIN standard adapters, output side

Coupling size	Adapter connections Output side			Adapter connections Output side			Adapter connections Output side		
	DIN	$J_4$ [kgm <sup>2</sup> ]	$m_4$ [kg]	DIN	$J_4$ [kgm <sup>2</sup> ]	$m_4$ [kg]	DIN	$J_4$ [kgm <sup>2</sup> ]	$m_4$ [kg]
250-280	90	0.0048	1.3	100	0.0050	1.4	120	0.0055	1.5
350-600	90	0.0036	1.0	100	0.0037	1.0	120	0.0038	1.0
500-1050/ 600-1150/ 700-1500	100	0.0073	1.6	120	0.0078	1.7	150	0.0091	1.8
1000-2400	120	0.0110	1.8	150	0.0120	1.9	180	0.0140	2.0
1600-4800	120	0.0220	2.4	150	0.0220	2.4	180	0.0260	3.2
2200-5300	120	0.0360	3.4	150	0.0380	3.6	180	0.0400	3.8
3400-11000	150	0.1310	7.4	180	0.1310	7.4	225	0.1360	7.8
5000-11500	180	0.3400	12.1	225	0.3420	11.9	250	0.3470	12.4

### Ordering example

Dynamometer side      DIN120

D                              120

Adapter designation: TOK350 - D - 120

### DIN adapter dimensions, output side

Size DIN	$D_{13}$ [mm]	$Z_4$	$D_{15}$	$D_{14}$ [mm]	$L_4$ <sup>1)</sup> [mm]	$L_5$ [mm]	$F_{min}$ [mm]
90	74.5	4	M8	47	30	15	3.0
100	84.0	6	M8	57	30	15	3.0
120	101.5	8	M10	75	30	15	3.0
150	130.0	8	M12	90	30	15	3.5
180	155.5	8	M14	110	30	15	4.5
225	196.0	8	M16	140	30	15	5.5
250	218.0	8	M18	140	30	15	6.5

<sup>i</sup> 1) If necessary different for TOK3400 and TOK5000

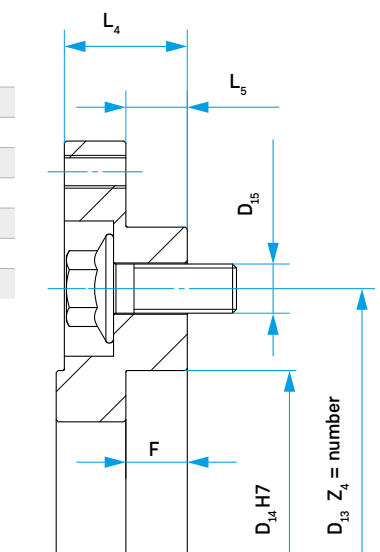



## Flywheel adapter SAE J 620, drive side

Engine flywheel SAE J 620

Size	D <sub>16</sub> [mm]	D <sub>17</sub> [mm]	D <sub>18</sub> [mm]	Z <sub>4</sub>
8	263.5	244.5	10	6
10	314.3	295.3	10	8
11.5	352.4	333.4	10	8
14	466.7	438.2	12	8
18	571.5	542.9	16	6

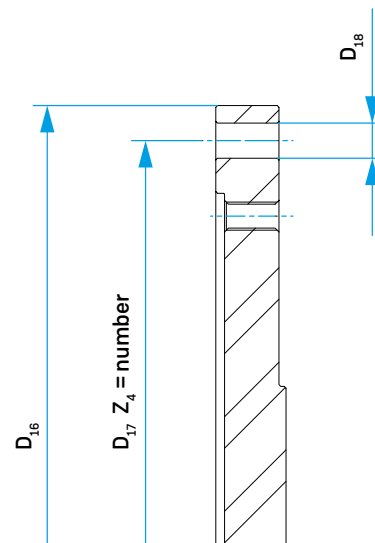

### Ordering example

Nominal torque of the engine side SAE8  
coupling

TOK1000 - E - 8

Adapter designation: TOK1000 - E - 8

## Dependence of speed on weight load

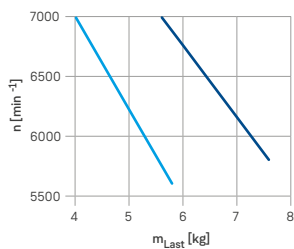

TOK250 TOK500  
TOK350 TOK600  
TOK700

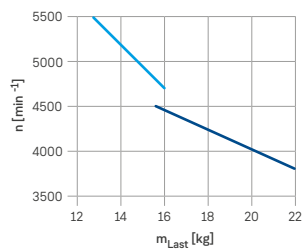

TOK1000 TOK1600

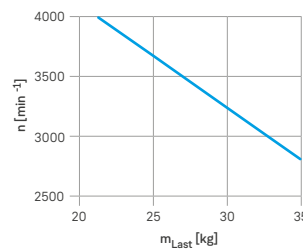

TOK2200

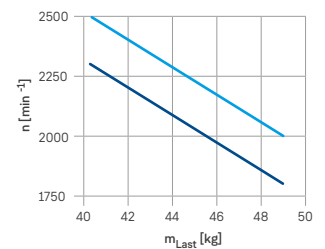

TOK3400 TOK5000

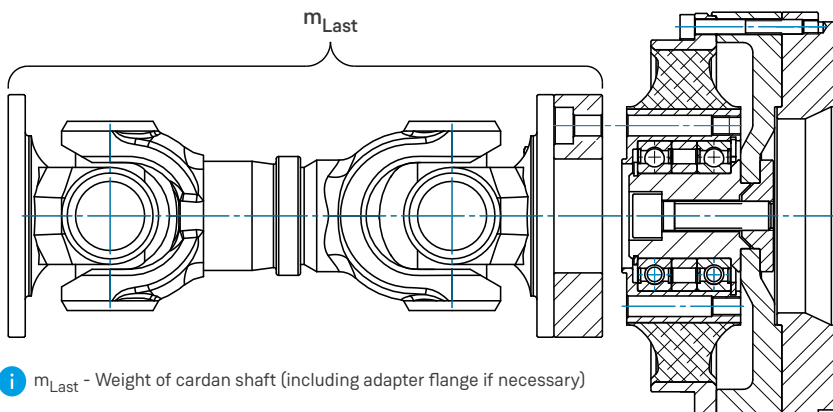

**i**  $m_{Last}$  - Weight of cardan shaft (including adapter flange if necessary)

## Data Required for Coupling Size Selection

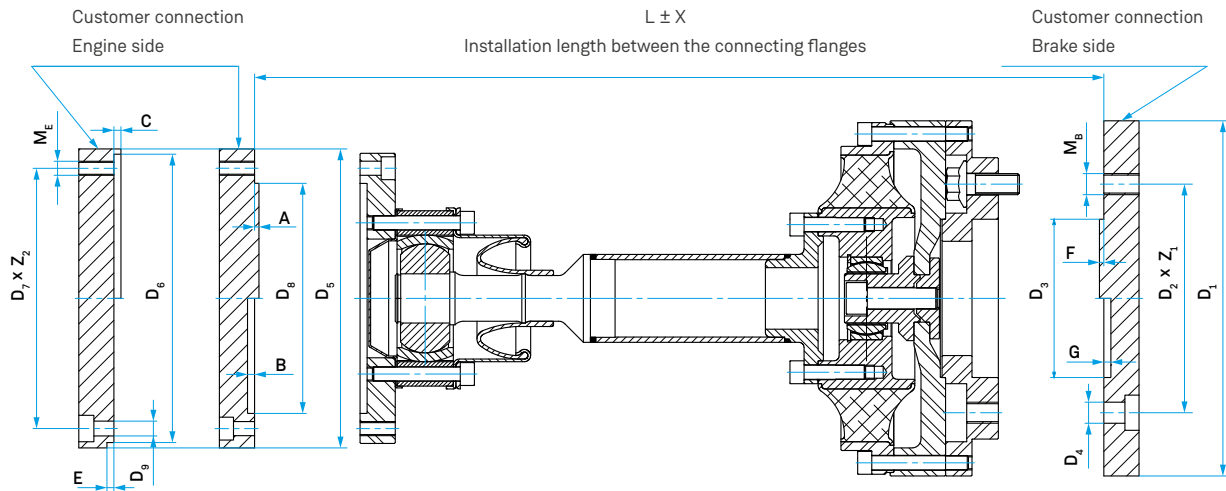

Engine	Please mark with a cross	Diesel	Gas	Gas	Turbo	Biturbo	Cylinder deactivation*		Connection dimensions, customer											
							yes	no	Engine			Brake								
Type/designation/ manufacturer									Symbol	Value	Unit	Symbol	Value	Unit						
									$D_5$		[mm]	$D_1$		[mm]						
									$D_6$		[mm]	$D_2$		[mm]						
									$D_7$		[mm]	$Z_1$		-						
									$Z_2$		-	$D_4$		[mm]						
									$D_9$		[mm]	$M_B$		-						
									$M_E$		-	$D_3$		[mm]						
									$D_8$		[mm]	$F$		[mm]						
									$A$		[mm]	$G$		[mm]						
									$B$		[mm]									
									$C$		[mm]	$L$		[mm]						
									$E$		[mm]	$X$		[mm]						
									Clutch shaft installation						Please mark with a cross					
								$n_{idle}$		[min <sup>-1</sup> ]	Directly between engine and brake or measuring flange (classic)									
								$T_{idle}$		[Nm]	Not directly on the engine (e.g. use of an intermediate bearing)									
								$P_{idle}$		[kW]	Vehicle coupling used?									
								$n$		[min <sup>-1</sup> ]	Dummy gear used? (if yes: specify J+Ct)									
								$T_{max}$		[Nm]	Operational displacements									
								$n_{max}$		[min <sup>-1</sup> ]	Symbol					Value	Unit			
								$T$		[Nm]	Axial displacement					$K_a$	[mm]			
								$P_{max}$		[kW]	Radial displacement					$K_r$	[mm]			
								$R/V_{xx}$		-	Angular displacement					$K_w$	[°]			
								$z$		-	Dyno					EC	DC	AC	Please mark with a cross	
								$i$		-	Controller frequency							[Hz]		
								$V_H$		[ccm]	Water brake									
								Hub		[mm]	Miscellaneous									
								Connecting rod length		[mm]	Type/designation									
								Oscillating mass per cylinder		[kg]	Mass moment of inertia reduced					$J_{Brake}$		[kgm <sup>2</sup> ]		
								Moments of inertia (engine + flywheel)		[kgm <sup>2</sup> ]	Mass moment of inertia reduced					$J_{Brake}$		[kgm <sup>2</sup> ]		
								Dual mass flywheel	yes/no		$J_1$		[kgm <sup>2</sup> ]	$J_2$		[kgm <sup>2</sup> ]	Ct	**	[Nm/rad]	
								Smallest operating point B1	n		[min <sup>-1</sup> ]	T		[Nm]	P		[kW]	t	[s]	Frequency/h
								Second smallest operating point B2	n		[min <sup>-1</sup> ]	T		[Nm]	P		[kW]	t	[s]	Frequency/h
								Lowest operating speed at full throttle	n		[min <sup>-1</sup> ]	Ambient temperature							[°C]	

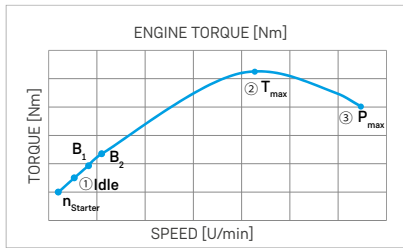

**i** \* Description of deactivation  
**\*\*** Provide dual mass flywheel characteristic curve











# TOK COUPLING SYSTEM



SIMPLY **POWERFUL.** 



## Industrial solutions:

-  Power generation
-  Mobile applications
-  Test benches
-  Pumps & compressors
-  Industry
-  Ship & port engineering

## Headquarter:

Dipl.-Ing. Herwarth Reich GmbH  
Vierhausstrasse 53 · 44807 Bochum  
 +49 234 95916-0  
 [mail@reich-kupplungen.com](mailto:mail@reich-kupplungen.com)  
 [www.reich-kupplungen.com](http://www.reich-kupplungen.com)

## Copyright ISO 16016 to be observed:

The reproduction, distribution and utilisation of this document as well as the communication of its contents to others without explicit authorisation is prohibited. Offenders will be held liable for the payment of damages. All rights reserved in the event of the grant of a patent, utility model or design. © REICH - Dipl.-Ing. Herwarth Reich GmbH

## March 2020 edition

The present TOK catalogue edition renders parts of the previous TOK catalogues obsolete. All dimensions in millimetres. We reserve the right to change dimensions and/or design without prior notice. Texts and illustrations, dimensional and performance data have been compiled with the utmost care. There is no guarantee, however, that the information is accurate; in particular, there is no guarantee that products will match the illustrations in terms of technology, colour, shape and configuration or that the products will correspond to the proportions of the illustrations. We also reserve the right to make changes due to printing errors or mistakes.